

Modular Cascaded H-Bridge Multilevel PV Inverter with Distributed MPPT for Grid-Connected Applications

¹ Nakkireddyvari Bhargavi, ² B.Parameswara Reddy M.Tech

¹ M.Tech Dept of EEE (PED), St.Mark Group of Educational Institutions, Affiliated to JNTUA, AP, India .

² Assistant Professor, Dept of EEE (PED), St.Mark Group of Educational Institutions, Affiliated to JNTUA, AP, India

Abstract: Due to the possibility of providing energy with much less dependence on the fossil fuels, renewable energy sources, in specified sun photovoltaic (PV) conversion have received elevated acceptance and progress in latest times. Big benefits of PV panels comprise easy and trustworthy power production and suitability for disbursed iteration. In addition the costs for photovoltaic modules is drastically lowering. To comprehend this issue, a control plan with modulation compensation scheme is likewise proposed. An exploratory three-stage seven-level cascaded H-bridge inverter has been manufactured using nine H-bridge modules (three modules for each stage). Each H-bridge module is associated with a 185-W solar panel. Simulation results are introduced to confirm the practicality of the proposed approach.

I. INTRODUCTION

Because of the lack of fossil fuels and natural causes created by ordinary power era, renewable energy, especially sun oriented energy, has turned out to be extremely well known. Solar electric-energy demand has become reliably by 20%–25% for each annum in the course of recent years, and the development is for the most part in system associated applications. With the exceptional market development in grid associated photovoltaic (PV) systems, there are expanding interests in grid associated PV arrangements.

Five inverter families can be characterized, which are identified with distinctive arrangements of the PV system: 1) central inverters; 2) string inverters; 3) multi string inverters; 4) ac module inverters; also, 5) cascaded inverters. The arrangements of PV systems are appeared in Fig. 1.

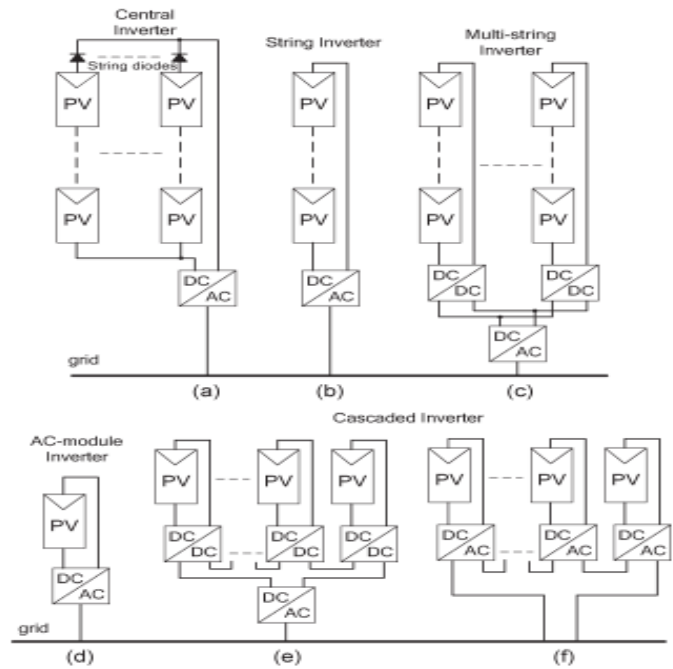

Fig.1. Configurations of PV systems. (a) Central inverter. (b) String inverter.(c) Multi string inverter. (d) AC-module inverter. (e) Cascaded dc/dc converter. (f) Cascaded dc/ac inverter.

Cascaded inverters comprise of a few converters associated in arrangement; in this way, the high power and/or high voltage from the mix of the numerous modules would support this topology in medium and huge grid associated PV systems. There are two sorts of cascaded inverters. Fig. 1(e) demonstrates a cascaded dc/dc converter association of PV modules. Each PV module has its own particular dc/dc converter, and the modules with their related converters are still associated in arrangement to make a high dc voltage, which is given to a rearranged dc/ac inverter. This methodology consolidates parts of string inverters and ac module inverters and offers the benefits of individual module

maximum power point (MPP) tracking (MPPT), however it is not so much exorbitant but rather more productive

than ac module inverters. Be that as it may, there are two power transformation stages in this design. The modular cascaded H-bridge multilevel inverter, which requires an isolated dc source for every H-bridge, is one dc/ac cascaded inverter topology. The different dc links in the multilevel inverter make autonomous voltage control conceivable. As an outcome, individual MPPT control in each PV module can be accomplished, and the energy reaped from PV panels can be maximized. In the interim, the particularity and ease of multilevel converters would position them as a prime hopeful for the up and coming era of efficient, robust, and reliable grid connected solar power electronics.

A measured cascaded H-bridge multilevel inverter topology for single-or three-stage grid associated PV systems is exhibited in this paper. The panel mismatches issues are tended to demonstrate the need of individual MPPT control, and a control plan with circulated MPPT control is then proposed. The distributed MPPT control plan can be connected to both single and three-stage systems. What's more, for the introduced three-stage grid associated PV system, if each PV module is worked at its own particular MPP, PV mismatches may acquaint unequal power supplied with the three-stage multilevel inverter, prompting unequal infused grid current. To adjust the three-stage grid current, modulation compensation is additionally added to the control system.

II. SYSTEM DESCRIPTION

Modular cascaded H-bridge multilevel inverters for single and three-stage grid associated PV systems are appeared in Fig. 2. Every stage comprises of n H-bridge converters associated in arrangement, and the dc connection of every H-bridge can be fed by a PV panel or a short string of PV panels. The cascaded multilevel inverter is associated with the grid through L channels, which are used to decrease the exchanging music in the current. By various mixes of the four switches in each H-bridge module, three output voltage levels can be created: $-v_{dc}$, 0 , or $+v_{dc}$. A cascaded multilevel inverter with n information sources will give $2n + 1$ levels to

orchestrate the air conditioner output waveform. This $(2n + 1)$ - level voltage waveform empowers the

diminishment of sounds in the incorporated current, lessening the measure of the required output channels. Multilevel inverters too have different points of interest, for example, diminished voltage weights on the semiconductor switches and having higher productivity when contrasted with other converter topologies.

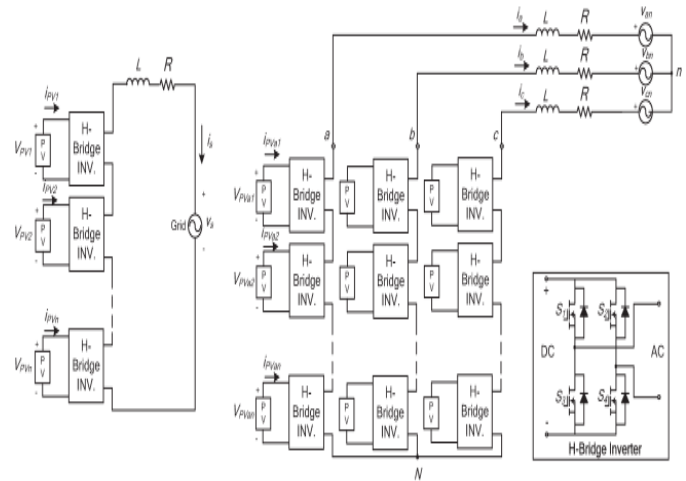

Fig. 2. Topology of the modular cascaded H-bridge multilevel inverter for grid-connected PV systems.

III. PANEL MISMATCHES

PV mismatch is an imperative issue in the PV system. Due to the unequal got irradiance, diverse temperatures, and maturing of the PV panels, the MPP of each PV module might be diverse. In the event that each PV module is not controlled autonomously, the productivity of the general PV system will be diminished.

In a three-phase grid-connected PV system, a PV mismatch may cause more problems. Aside from decreasing the overall efficiency, this could even introduce unbalanced power supplied to the three-phase grid-connected system. If there are PV mismatches between phases, the input power of each phase would be different. Since the grid voltage is balanced, this difference in input power will cause unbalanced current to the grid, which is not allowed by grid standards. For example, to unbalance the current per phase more than

10% is not allowed for some utilities, where the percentage imbalance is calculated by taking the

maximum deviation from the average current and dividing it by the average current.

To tackle the PV mismatch issue, a control plan with individual MPPT control and balance pay is proposed. The points of interest of the control plan will be examined in the tracking segment.

IV. CONTROL SCHEME

A. Distributed MPPT Control

Keeping in mind the end goal to dispose of the antagonistic impact of the befuddles and expand the productivity of the PV system, the PV modules need to work at various voltages to enhance the usage per PV module. The different dc links in the cascaded H-bridge multilevel inverter make free voltage control conceivable. To figure it out individual MPPT control in each PV module, the control plan proposed in [19] is redesigned for this application. The circulated MPPT control of the three-stage cascaded H-bridge inverter is appeared in Fig. 3. In every H-bridge module, a MPPT controller is added to create the dc-link voltage reference. Every dc-link voltage is contrasted with the comparing voltage reference, and the whole of all mistakes is controlled through an aggregate voltage controller that decides the current reference I_{dref} . The receptive current reference I_{qref} can be set to zero, or if receptive power pay is required, I_{qref} can additionally be

given by a responsive current adding machine. The synchronous reference outline stage bolted circle (PLL) has been used to discover the stage edge of the grid voltage. As the exemplary control plan in three-stage systems, the grid streams in abc directions are changed over to dq organizes and controlled through proportional-integral (PI) controllers to produce the adjustment record in the dq facilitates, which is then changed over back to three stages.

The disseminated MPPT control plan for the single-stage system is about the same. The aggregate voltage controller gives the greatness of the dynamic current

reference, and a PLL gives the recurrence and stage point of the dynamic current reference. The present circle then gives the tweak list. To make each PV module work at its

own MPP, take stage an as a case; the voltages v_{dca2} to v_{dcn} are controlled exclusively through $n - 1$ circles. Every voltage controller gives the regulation record extent of one H-bridge module in stage a. After increased by the regulation record of stage a, $n - 1$ regulation records can be gotten. Additionally, the regulation record for the primary H-bridge can be acquired by subtraction. The control plans in stages b also, c is just about the same. The main distinction is that all dc-link voltages are directed through PI controllers, and n adjustment record extents are acquired for every stage.

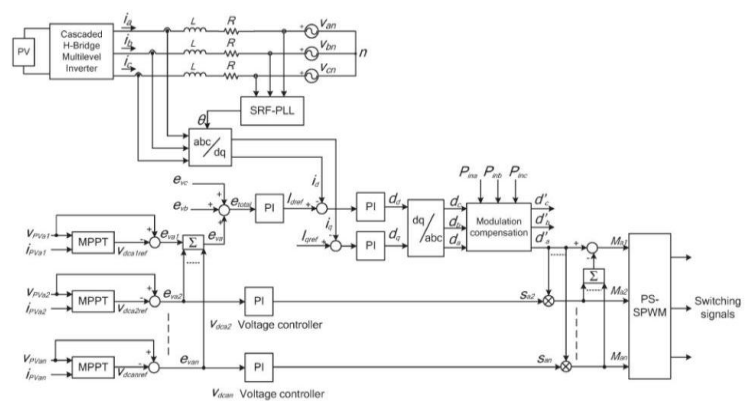

Fig. 3. Control scheme for three-phase modular cascaded H-bridge multilevel PV inverter.

A phase-shifted sinusoidal pulse width modulation switching scheme is then connected to control the switching devices of each H-bridge. The incremental conductance technique has been utilized in this paper. It lends itself well to computerized control, which can effectively monitor past estimations of voltage and current and settle on all choices.

B. Modulation Compensation

As specified before, a PV mismatch may bring about additional problems to a three-stage modular cascaded H-bridge multilevel PV inverter. With the individual MPPT control in each H-bridge module, the info solar power of

every stage would be distinctive, which acquaints uneven current with the grid. To tackle the issue, a zero sequence voltage can be powered upon the stage legs so as to influence the present streaming into each stage. In the

event that the redesigned inverter output stage voltage is corresponding to the uneven power, the present will be adjusted.

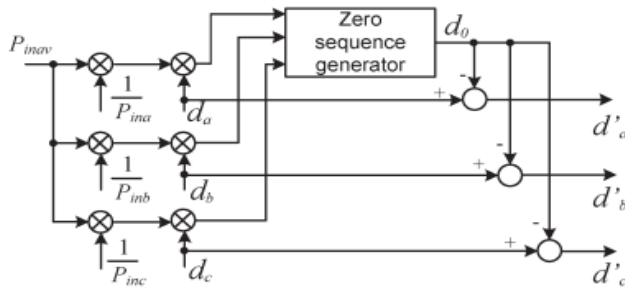

Fig. 4. Modulation compensation scheme.

In this manner, the modulation compensation block, as appeared in Fig. 6, is added to the control arrangement of three-stage modular cascaded multilevel PV inverters. The key is the manner by which to overhaul the balance record of every stage without expanding the complexity of the control system. To start with, the unequal power is weighted by proportion r_j ,

This is ascertained as

$$r_j = \frac{P_{inav}}{P_{inj}} \quad (1)$$

Where P_{inj} is the info power of stage ($j = a, b, c$), and P_{inav} is the normal info power. At that point, the infused zero arrangement adjustment file can be produced as

$$d_0 = \frac{1}{2} [\min(r_a \cdot d_a, r_b \cdot d_b, r_c \cdot d_c) + \max(r_a \cdot d_a, r_b \cdot d_b, r_c \cdot d_c)] \quad (2)$$

Where d_j is the adjustment record of stage ($j = a, b, c$) and is dictated by the present circle controller. The adjustment record of every stage is redesigned by

$$d'_j = d_j - d_0. \quad (3)$$

Just straightforward estimations are required in the plan, which won't build the many-sided quality of the control

system. A case is displayed to demonstrate the adjustment remuneration plot all the more unmistakably. Expect that the information power of each stage is unequal

$$P_{ina} = 0.8 \quad P_{inb} = 1 \quad P_{inc} = 1. \quad (4)$$

By infusing a zero succession tweak list at $t = 1$ s, the adjusted tweak file will be redesigned, as appeared in Fig. 7. It can be

seen that, with the remuneration, the overhauled balance record is uneven relative to the power, which implies that the output voltage (v_{jN}) of the three-stage inverter is uneven; however this creates the sought adjusted grid current.

V. SIMULATION RESULTS

To confirm the proposed control plot, the three-stage grid connected PV inverter is mimicked in two distinctive conditions. In the first place, all PV panels are worked under the same irradiance $S = 1000 \text{ W/m}^2$ and temperature $T = 25 \text{ }^\circ\text{C}$. At $t = 0.8$ s, the sun powered irradiance on the first and second panels of stage a declines to 600 W/m^2 , and that for alternate panels sticks with it same. The dc-link voltages of stage are appeared in Fig. 8. At the starting, all PV panels are worked at a MPP voltage of 36.4 V . As the irradiance changes, the first and second dc-link voltages abatement and track the new MPP voltage of 36 V , while the third panel is still worked at 36.4 V .

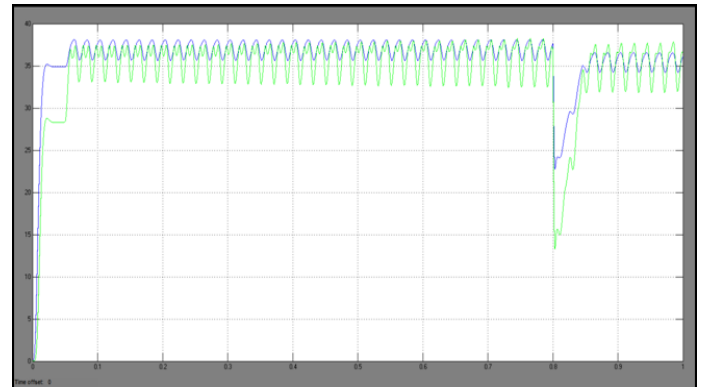

FIG 5:dc link voltage of modules 1 and 2.

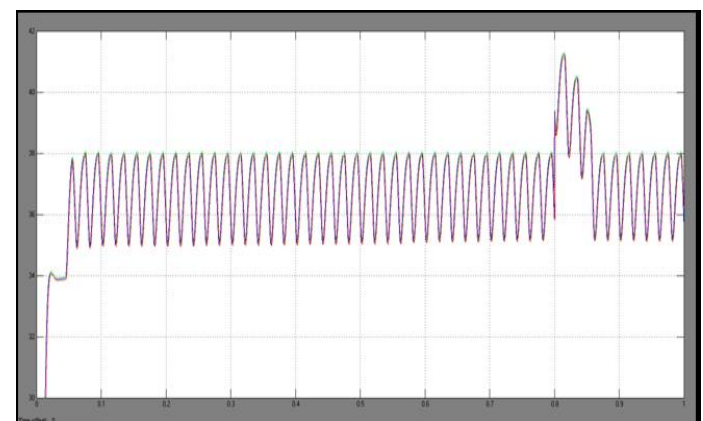

Fig. 6 Dc link voltage of module 3.

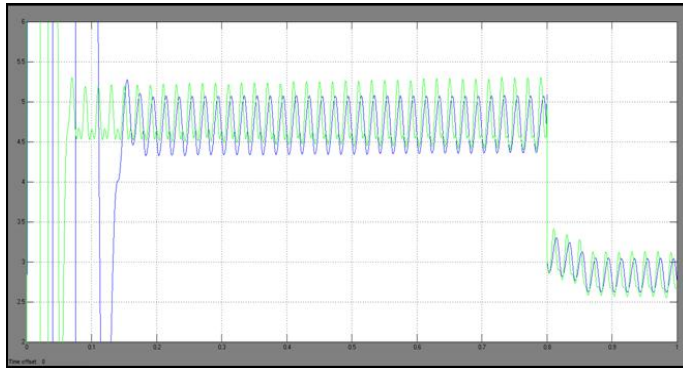

Fig 7: pv currents of phase a with distributed mppt(t=25).

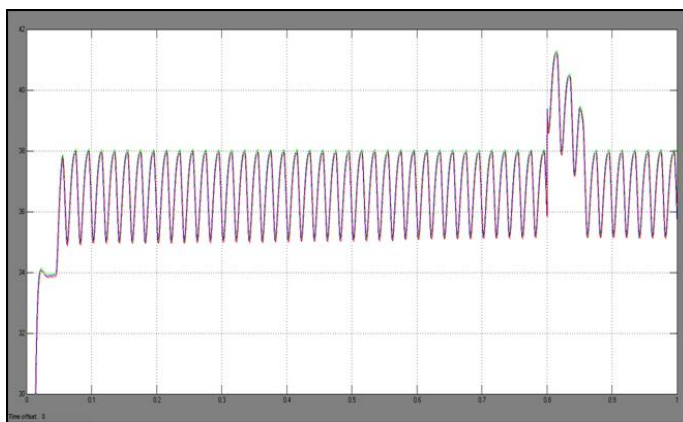

Fig 8.dc link voltages of phase b with distributed MPPT (T=25)

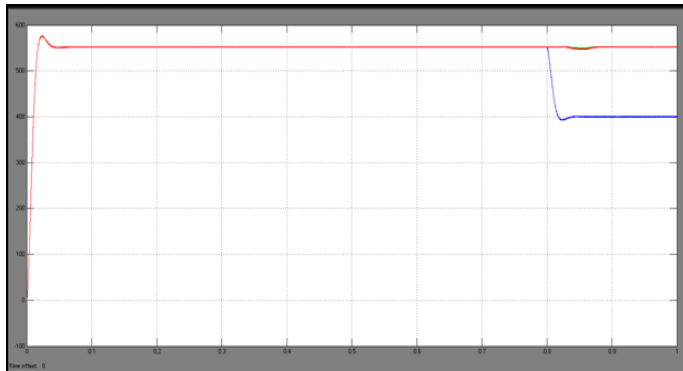

Fig 9 Power extracted from PV panels with distributed MPPT

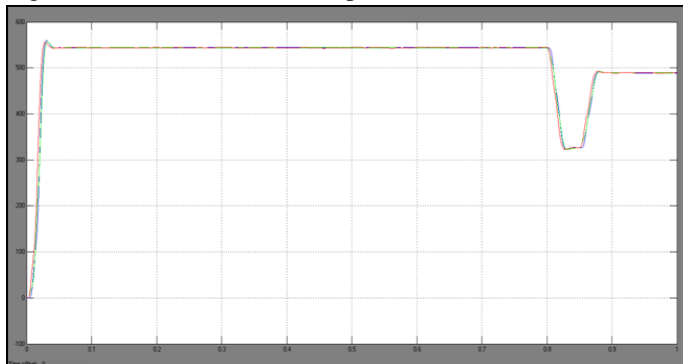

Fig 10. Power injected to the grid with modulation compensation.

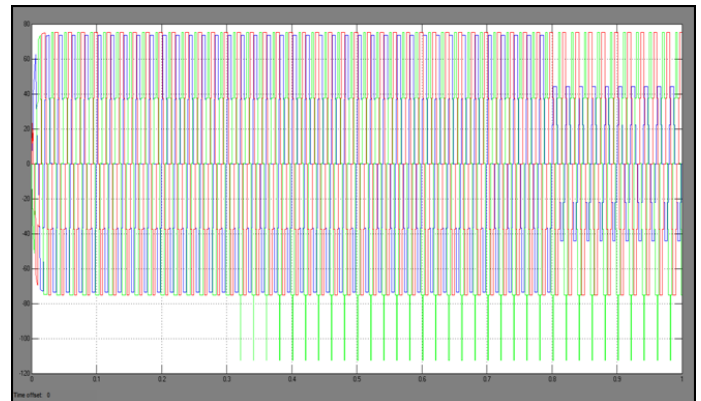

Fig 11. Three-phase inverter output voltage waveforms with modulation compensation.

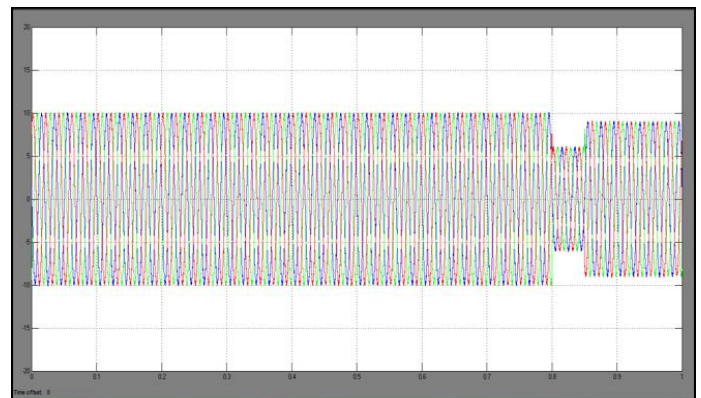

Fig 12. Three-phase grid current waveforms with modulation compensation.

VI. CONCLUSION

Modular cascaded H-bridge multilevel inverter for grid-connected PV applications has been presented. The multilevel inverter topology will help to improve the utilization of connected PV modules if the voltages of the separate dc links are controlled independently. Thus, a distributed MPPT control scheme for both single and three-phase PV systems has been applied to increase the overall efficiency of PV systems. For the three-phase grid-connected PV system, PV mismatches may introduce unbalanced supplied power, resulting in un-balanced injected grid current. A modulation compensation scheme, which will not increase the complexity of the



control system or cause extra power loss, is added to balance the grid current.

REFERENCES

- [1] J. M. Carrasco *et al.*, “Power-electronic systems for the grid integration of renewable energy sources: A survey,” *IEEE Trans. Ind. Electron.*, vol. 53, no. 4, pp. 1002–1016, Jun. 2006.
- [2] S. B. Kjaer, J. K. Pedersen, and F. Blaabjerg, “A review of single-phase grid connected inverters for photovoltaic modules,” *IEEE Trans. Ind. Appl.*, vol. 41, no. 5, pp. 1292–1306, Sep./Oct. 2005.
- [3] M. Meinhardt and G. Cramer, “Past, present and future of grid connected photovoltaic- and hybrid power-systems,” in *Proc. IEEE PES Summer Meet.*, 2000, vol. 2, pp. 1283–1288.
- [4] M. Calais, J. Myrzik, T. Spooner, and V. G. Agelidis, “Inverter for single-phase grid connected photovoltaic systems—An overview,” in *Proc. IEEE PESC*, 2002, vol. 2, pp. 1995–2000.
- [5] J. M. A. Myrzik and M. Calais, “String and module integrated inverters for single-phase grid connected photovoltaic systems—A review,” in *Proc. IEEE Bologna Power Tech Conf.*, 2003, vol. 2, pp. 1–8.
- [6] F. Schimpf and L. Norum, “Grid connected converters for photovoltaic, state of the art, ideas for improvement of transformerless inverters,” in *Proc. NORPIE*, Espoo, Finland, Jun. 2008, pp. 1–6.
- [7] B. Liu, S. Duan, and T. Cai, “Photovoltaic DC-building-module-based BIPV system—Concept and design considerations,” *IEEE Trans. Power Electron.*, vol. 26, no. 5, pp. 1418–1429, May 2011.
- [8] L. M. Tolbert and F. Z. Peng, “Multilevel converters as a utility interface for renewable energy systems,” in *Proc. IEEE Power Eng. Soc. Summer Meet.*, Seattle, WA, USA, Jul. 2000, pp. 1271–1274.