



Reactive Power Management - Hierarchical Droop Control for Islanded Microgrid

¹Ugranam Ramesh ²C.Kiran Kumar M.Tech

¹M. Tech, Dept of EEE (EPS), St.Mark Group of Educational Institutions, Affiliated to JNTUA, AP, India

²Assistant Professor, Dept. of (EPS), St.Mark Group of Educational Institutions, Affiliated to JNTUA, AP, India

Abstract— In this work A micro grid (MG) is a local energy system consisting of a number of energy sources (e.g., wind turbine or solar panels among others), energy storage units, and loads that operate connected to the main electrical grid or autonomously. MGs provide flexibility, reduce the main electricity grid dependence, and contribute to changing large centralized production paradigm to local and distributed generation. However, such energy systems require complex management, advanced control, and optimization. Moreover, the power electronics converters have to be used to correct energy conversion and be interconnected through common control structure is necessary. Classical droop control system is often implemented in MG. It allows correct operation of parallel voltage source converters in grid connection, as well as islanded mode of operation. However, it requires complex power management algorithms, especially in islanded MGs, which balance the system and improves reliability. The novel reactive power sharing algorithm is developed, which takes into account the converters parameters as apparent power limit and maximum active power.

Key Words: Micro grid, Renewable energy resource, Distributed generation, Droop control.

I. INTRODUCTION

Fossil fuel reserves are going to vanish in the near future, so human beings will need to find alternative energy sources to avoid this disaster. Increased concerns of rising price of conventional energy (e.g. fossil fuel) and environmental impacts are fast shifting the focus to the use of renewable and sustainable energy sources. The use of renewable energy sources is becoming popular along with fossil fuels depletion. The unpredictable and intermittent nature of renewable energy sources have kept them from integrating with the utility grid. However, the concept of micro grid has opened up the scope of incorporating renewable energy sources into the conventional grid, without a direct coupling with the conventional grid components. This is possible due to the unique feature of a micro grid, which allows both synchronized grid connected operation and islanded operation in case of instabilities or power outages in the main grid.

Micro grid (MG) is a separate system that produces and stores electrical energy, which consists of renewable

energy sources (RES), local loads, and energy storage based on batteries or super capacitors. It is inherent part of modern and popular smart grids which includes also intelligent buildings, electrical car stations, etc. All RES are using power electronics devices (e.g., converters), which number significantly increasing and costs decreasing in range 1%–5% every year. RES are usually connected to the grid and many installations cause the parallel operation of RES close to each other. This is one of reasons to future change of the classical structure of electrical power systems, toward new solution containing distributed generation, energy storage, protection and control technologies, and improving their performances.

MG is highly advanced system from control and communication point of view. It has to manage power for local loads as well as control all converters with high efficiency and accuracy, especially when MG operates as islanded system. Islanding mode of operation provide the uninterruptible power supply for local loads during grid faults. The performances of islanded MG are specified according to IEEE. With increasing number of RES applications, operating parallel, close to each other (few km) and with developed islanded mode of operation, the MGs are become perfect solution for RES integration

Fundamental algorithms of ac MGs are based on master–slave control or hierarchical droop control. The first solution includes only one converter with voltage control loop (VCL), operating as a master, and others operating in current control loop (CCL)—slaves. The produced power is controlled by sources with CCL and the voltage amplitude and frequency is keeping in point of common coupling (PCC) by master unit. Disadvantage of this solution is no possibility to connect other VCL sources to MG, which are the most popular and used RES solutions. The second control solution, called droop control, includes many VCL sources and provides possibility to many different RES interconnection. The idea of droop control is based on active and reactive power related to voltage frequency and amplitude droop on coupled impedances. Unfortunately, classical droop control method with proportional droop coefficients does not provides proper reactive power sharing between converters connected to common ac bus. In classical approach, the equal reactive power sharing (ERPS) can be obtained only when active powers are equal and

droop coefficients are well chosen. When active powers are changing, the reactive power sharing cannot be controlled causing overload or reactive power circulation between converters. Moreover, the important issue in droop control is static trade-off between voltage regulation and reactive power. For increasing reactive power, the voltage droop on converter's output impedance also increase, what may cause over voltage. In order to provide appropriate power sharing and minimize the risk of converter damage the many additional aspects (e.g., nominal apparent power, instantaneous active power, nominal voltage of converter)

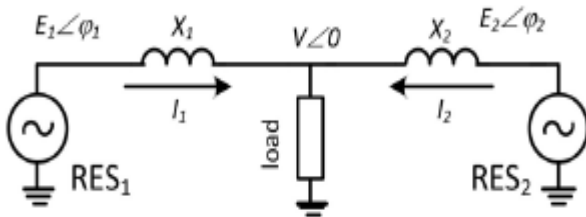

Fig. 1: Equivalent circuit of parallel connected VSIs.

There are only few papers describing reactive power sharing between parallel operating converters in islanded ac MGs. The researchers focused on ERPS between all RES usually controlled by MG central control unit or implemented as virtual impedances. From the other hand, researches consider reactive power sharing in order to optimize transmission power losses by appropriate optimization algorithm (e.g., particle swarm optimization), which can be neglected in MGs, hence the short distances and the line impedances are low.

However, algorithms described in literature are not considering capabilities of single RES, which have limited apparent power. If active power, usually calculated from maximum peak power tracking (MPPT) algorithms, obtain almost nominal apparent converter limit the equal power sharing algorithms cannot be used, because the overload can occur, what leads to damage or exclusion from operation of RES unit. The new reactive power sharing algorithm is developed and presented in this project. In Section I, the current solutions and problems of reactive power sharing are described.

II. Existing method

The first solution includes only one converter with voltage control loop (VCL), operating as a master, and others operating in current control loop (CCL) slaves. The produced power is controlled by sources with CCL and the voltage amplitude and frequency is keeping in point of common coupling (PCC) by master unit. Disadvantage of this solution is no possibility to connect other VCL sources to MG, which are the most popular and used RES solutions. The second control solution, called droop control, includes many VCL sources and provides possibility to many different RES interconnection.

There are only few papers describing reactive power sharing between parallel operating converters in islanded ac MGs. The researchers focused on ERPS between all RES

usually controlled by MG central control unit or implemented as virtual impedances. From the other hand, researches consider reactive power sharing in order to optimize transmission power losses by appropriate optimization algorithm (e.g., particle swarm optimization), which can be neglected in MGs, hence the short distances and the line impedances are low.

However, algorithms described in literature are not considering capabilities of single RES, which have limited apparent power. If active power, usually calculated from maximum peak power tracking (MPPT) algorithms, obtain almost nominal apparent converter limit the equal power sharing algorithms cannot be used, because the overload can occur, what leads to damage or exclusion from operation of RES unit.

III. Proposed method

The new reactive power sharing algorithm is developed and presented in this paper.

A. CLASSICAL DROOP CONTROL

When at least two RES are connected through energy converters to the MG, the droop control method is often applied, which provides the correct parallel operation of voltage source converters (VSI). The equivalent circuit of two converters connected to common ac MG bus can be presented by Fig.1. Presented scheme is similar to the equivalent circuit of synchronous generator; hence the active and reactive power of kth converter connected to ac MG can be described as

$$P_k = \frac{E_k V}{X_k} \sin \phi_k \quad \dots (1)$$

$$Q_k = \frac{E_k V \cos \phi_k - V^2}{X_k} \quad \dots (2)$$

where P, active power; E, converter voltage amplitude; V, voltage amplitude in PCC; X, coupling impedance; and ϕ , angle of converter voltage (see Fig.1).

Based on above equations it can be assumed as below.

- 1) Active power P mainly depends on ϕ , which is changing by ω .
- 2) Reactive power Q depends on voltage amplitude E

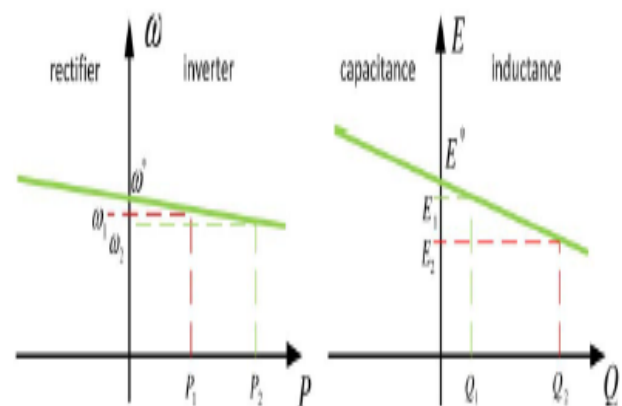

Fig. 2: P- ω and Q-E droop characteristics.

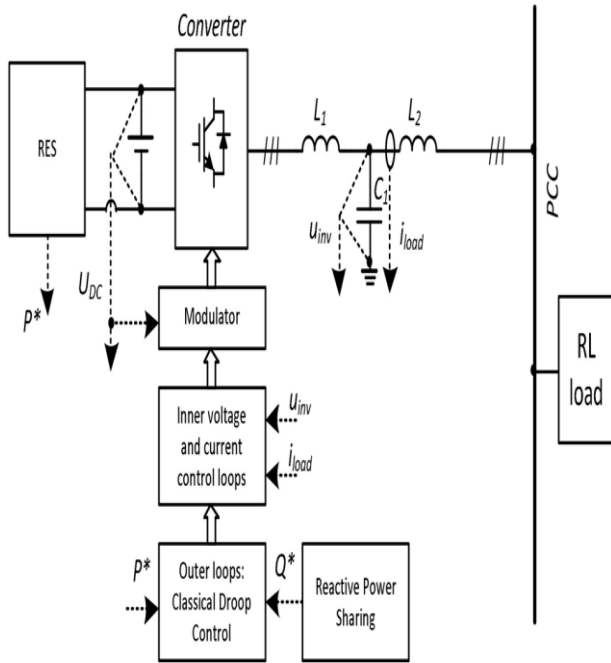

Fig. 3: Block scheme of control structure for one of the converters in islanded MG.

Hence, the P- ω and Q-E droop characteristics can be drawn (Fig. 2). In order to implement these characteristics in VSI control algorithm, the outer droop control loops are created (Fig. 3), which can be described by

$$\omega = \omega^* - G_p(s)(P - P^*) \quad \dots (3)$$

$$E = E^* - G_q(s)(Q - Q^*) \quad \dots (4)$$

where, E and ω are referenced voltage amplitude and frequency for inner control loops, E* and ω^* are nominal voltage amplitude and frequency, P and Q are calculated active and reactive power, P* and Q* are the active and reactive power referenced values, and Gp(s) and Gq(s) are corresponding transfer functions.

Typically in classical droop control Gp(s) and Gq(s) are proportional (constant) droop coefficients. It has happened, when MG not includes any energy storage and total load cannot absorb total injected power. These proportional coefficients can be calculated by (5) and (6). Block schemes of P- ω and Q-E control loops is presented in Fig. 4

$$G_p(s) = m = \frac{\Delta\omega_{max}}{P_{max}} \quad \dots (5)$$

$$G_q(s) = n = \frac{\Delta E_{max}}{Q_{max}} \quad \dots (6)$$

where, m, active power coefficient; n, reactive power coefficient; $\Delta\omega_{max}$, maximum allowed voltage frequency droop; ΔE_{max} , maximum allowed voltage amplitude droop; P_{max} , maximum allowed active power; and Q_{max} , maximum allowed reactive power.

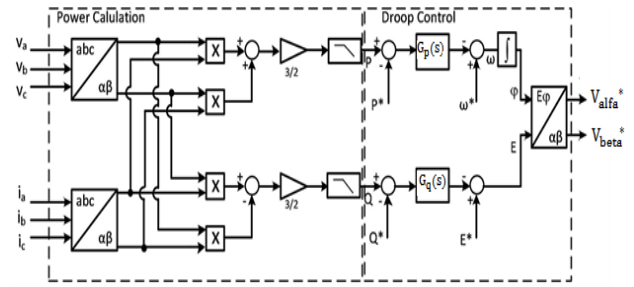

Fig. 4: Block scheme of classical droop control.

IV. PROPORTIONAL REACTIVE POWER SHARING

A. Development of PRPS Algorithm

In order to manage reactive power in islanded ac MG the instantaneous active power and nominal apparent power of each converter have to be taking into consideration. Based on Fryze power theory, that power can be represented by orthogonal vectors, which lengths are active and reactive power and their vector sum is equal to the apparent power. The reactive power limit for each converter can be calculated

$$Q_{max} = \sqrt{S_N^2 - P^2} \quad \dots (7)$$

where Q_{max} is the maximum of possible converter's reactive power, SN is the nominal apparent power of converter, P is the instantaneous active power of converter. In this project the harmonic (distortion) power is neglecting since only resistive inductive load is considered.

This relation for several converters with different possible nominal apparent powers and equal reactive powers (three converters in this example) can be interpreted graphically.

In power balanced system the vector sum of converter's apparent powers is equal to load apparent power regardless of the power management method, however, the algebraic sum of apparent powers is different for each control strategy. As a result, there is possible situation, that sum of converter's apparent powers are higher than the demand, which may lead to converters operating with maximum apparent power. Furthermore, if control priority is keeping maximum active power, the overload of converter can occur, for converter 1, what is not acceptable, because it cause disable or damage of this device.

In order to improves the reactive power management and keeping total generated apparent power below maximum level as long as possible, the proposed reactive control algorithm is keeping relation $S_L / \sum S_k$ on the highest level. It will allow better exploitation of each RES in whole MG, what can increase possible to active power generation of each converter without reaching of apparent power limit.

When converters are operating with apparent powers much lower than nominal parameters, the above relation is equal one and reactive power is sharing proportional to active power of each converter based on (8).

Unfortunately, this situation is only one of possible case and the limitations of converters have to be considered in

reactive sharing control algorithm in order to avoid overloads and developed complete control strategy. Hence, two additional conditions (9) and (10) have to be fulfilled for each k th converter. First condition prevents overloading of converter and the second one must be fulfilled to preserve the balance of reactive power in islanded MG.

The relation $S_L / \sum S_k$ in limited cases is lower than one, but it is keeping on highest possible level providing the best exploitation of RES with maximum active power

$$Q_{uk} = \frac{Q_L}{P_L} P_k \quad \dots (8)$$

$$P_k^2 + Q_k^2 = S_k^2 \leq S_{Nk}^2 \quad \forall K \quad \dots (9)$$

$$\sum_K Q_k = Q_L \quad \forall K \quad \dots (10)$$

where, Q_{uk} , calculated reactive power value for unlimited case; Q_L , total reactive power demand; P_L , total active power; P_k , active power of “ k ” converter; Q_k , reactive power of k converter; S_k , apparent power of k converter; and S_{Nk} , nominal apparent power of k converter.

Based on (8)–(10) and described analysis of reactive power sharing novel control algorithm was developed. The flowchart of the algorithm is shown in Fig. 5. In first stage system parameters are saved in K -elements tables, where K —number of converters, $P[K]$ —measured active powers, $SN[K]$ —nominal apparent powers. Furthermore, limits of reactive powers for each converter Q_{maxk} , as well as total active power P_L are calculated

$$P_L = \sum_K P_k \quad \dots (11)$$

In the next stage, the auxiliary parameter Q_{sum} , defined as a sum of reference reactive powers of all limited and unlimited converters, is compared with load reactive power. This parameter allows checking if reactive power balance is retained. When Q_{sum} , as a result of stages 3–5 described below is different than total reactive power Q_L , then algorithm is going to stage 3, otherwise the stage 6 followed and final referenced values of reactive power Q_k^* are defined for each converter.

In stages 3–5 the main calculation process of the reference values is executed. Firstly, the reactive power values proportional to active powers are calculated (stage 3). The proportionality factor is composed of parameters P_{rest} and Q_{rest} , which are total active and reactive power P_L and Q_L in unlimited case, otherwise they are smaller by excluding all active and reactive powers of limited converters (stage 5). Next, the limitation is checked (stage 4) and the reference value is set to maximum or to proportional. Depending on the result, auxiliary parameters Q_{lim} , P_{lim} or Q_{unl} , P_{unl} are calculated, which are sums of active and reactive power of converters operating with maximum apparent power or below it correspondingly (stage 4). Then after all K iterations, the parameters P_{rest} , Q_{rest} , Q_{sum} are calculated and the algorithm is going back

to stage 2, where the condition (10) is checked, as mentioned above.

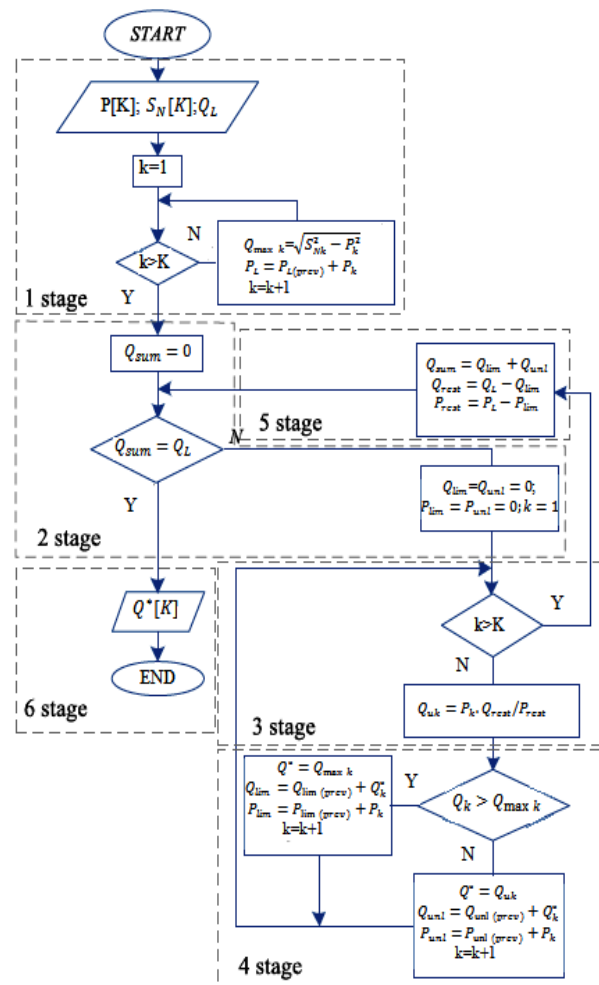

Fig. 5: Block diagram of developed reactive power sharing algorithm.

B. Implementation of Developed Algorithm

For more extensive MG (e.g., number of sources $K > 10$), the calculation of final reference values in one common control Fig. 5. Block diagram of developed reactive power sharing algorithm. unit [e.g., secondary control unit (SCU)] may be long and not be possible, especially if calculations in SCU have to be done in one converter switching period (usually 100–500 μ s). Hence, based on Fig. 5 the algorithm can be splitted between all primary control units (PCU) containing inner control loops and SCU, which is mainly responsible for compensating the voltage amplitude and frequency deviation caused by droop control in PCU.

As a result, the time calculation in SCU may be reduced improving control dynamic and transient time. Proposed implementation of presented algorithm allows executing many processes parallel in PCUs. The block scheme of proposed control algorithm implemented in PCUs and SCU The algorithm calculates the reactive power limit (7) and proportional reactive power value for unlimited cases (8) in each PCU independently. Furthermore, the auxiliary parameters P_{sk} , Q_{sk} are defined (11), (12), based on actual reactive power reference value Q^* . In order to fulfill

condition (10) the additional value of reactive power Q_k has to be added to value of unlimited case Q_{uk} for each unlimited converter. It is defined by (13) and depends on sum of active power of limited converters P_{sL} , sum of reactive power of limited converters Q_{sL} , total active and reactive powers P_L and Q_L , reactive power value of unlimited case Q_{uk} and auxiliary parameter Q_{sk} . The parameter Q_k can be different for each k , proportionally to P_k , hence the PRPS for unlimited converters.

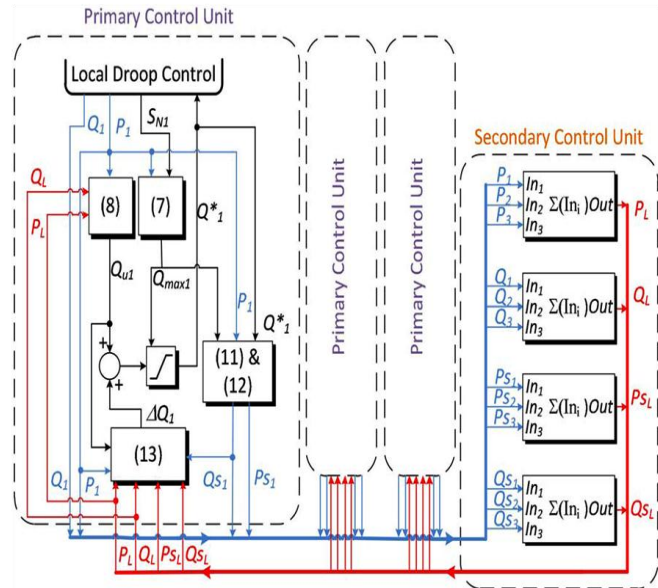

Fig. 6: Block diagram of developed reactive power sharing algorithm in real-time implementation.

is still satisfied. The final reference values of reactive powers are calculated, when the all conditions (9), (10) are fulfilled and the transferred data between PCUs and SCU do not change in next converter switching period. Furthermore, the steady state of reactive power sharing in MG is obtained when the signals from controllers in inner control loops are established. This process may take a few hundred milliseconds, depending on the number of RES

$$P_{s_k} = \begin{cases} P_k & \text{if } Q_k = Q_{\max k} \\ 0 & \text{otherwise} \end{cases} \quad \dots (12)$$

$$Q_{s_k} = \begin{cases} Q_k & \text{if } Q_k = Q_{\max k} \\ 0 & \text{otherwise} \end{cases} \quad \dots (13)$$

$$\Delta Q_k = \begin{cases} \left(\frac{P_k}{P_L - P_{sL}} \cdot (Q_L - Q_{sL}) - Q_{uk} \right) & \text{if } Q_{uk} \neq Q_{s_k} \\ 0 & \text{otherwise} \end{cases} \quad \dots (14)$$

$$Q_k^* = Q_{uk} + \Delta Q_k \quad \dots (15)$$

C. PRPS Algorithm in Real Distributed Control System

In real distributed control system, several different processors in PCUs and remote SCU need to share their computational results. Any synchronization between PCUs and SCU are not required in presented solution. The delay can be neglected for modern communication infrastructure with transmission speed in range of megabit per second (Mb/s) and only few km distances between control units in all MG elements. Therefore, application of distributed

control system for developed algorithm was proposed (Fig. 6) what can allow for higher computational speed.

One of the possible communication problems is loss data in some periods. However, in presented solution, where the transferred data are used only to calculations of referenced reactive powers for the lowest control loops in PCUs, it may cause the longer transient time (worse dynamic of control signals). Another problem in distributed control system is different sampling time for PCUs (usually 5–10 kHz) and SCU [it can work with high sampling frequency (e.g., 40 kHz)]. These differences will not affect the proper operation of converters in MG.

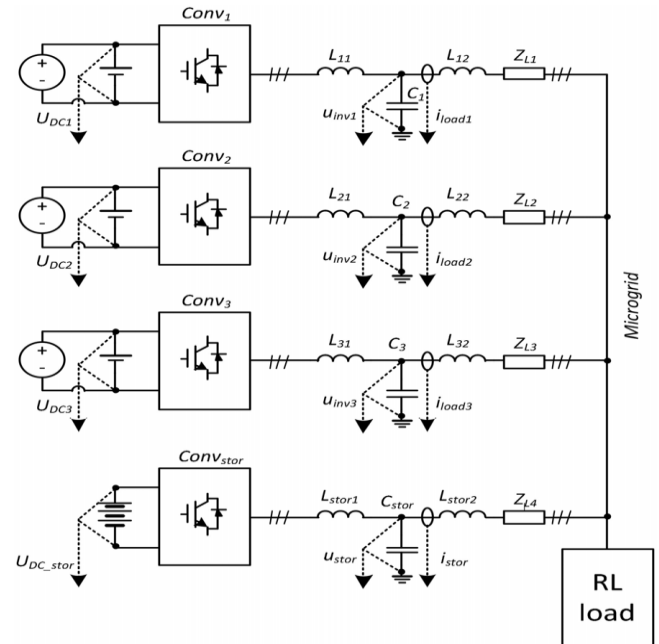
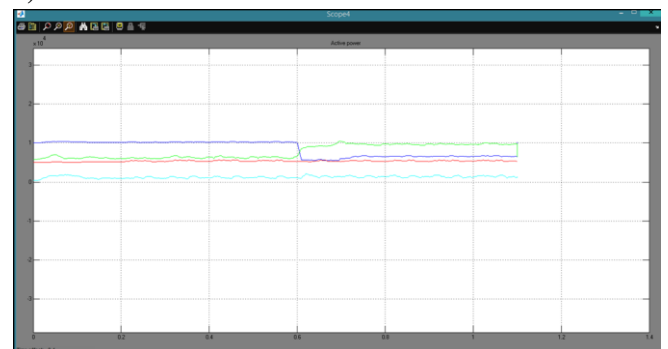

Fig. 7: Block scheme of simulation model.

CLASSICAL DROOP CONTROL OUTPUTS

1) ACTIVE POWER



2) REACTIVE POWER

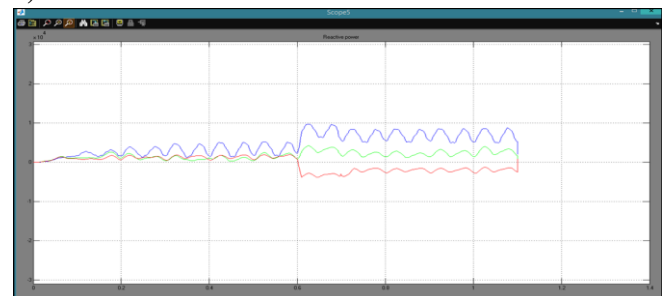

3) APPARENT POWER

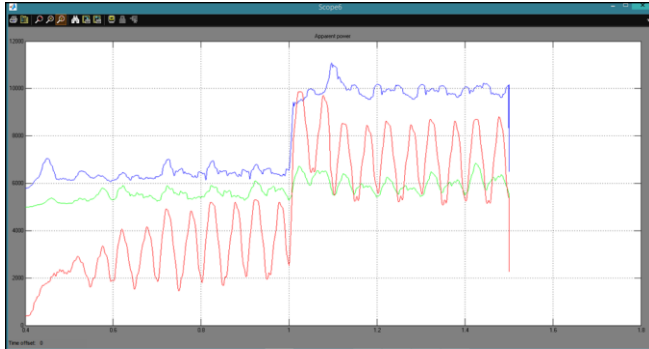

Powers of converters in islanded MG without reactive power management with step change of maximum active power from RESs: p_1 , p_2 , p_3 , $p_{storage}$, converters active powers; p_{mppt1} , p_{mppt2} , p_{mppt3} , maximum active powers calculated from MPPT; q_1 , q_2 , q_3 , converters reactive powers; S_1 , S_2 , S_3 , converters apparent powers; and SN_1 , SN_2 , SN_3 , converters nominal apparent powers.

EQUAL REACTIVE POWER SHARING OUTPUTS

1) ACTIVE POWER

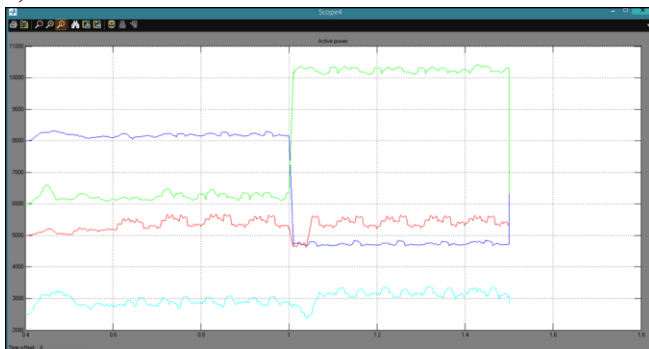

2) REACTIVE POWER

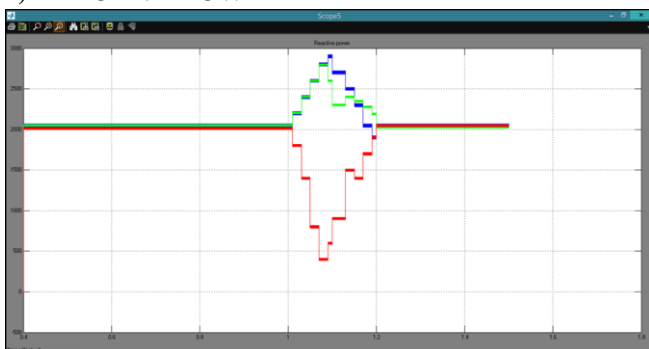

3) APPARENT POWER

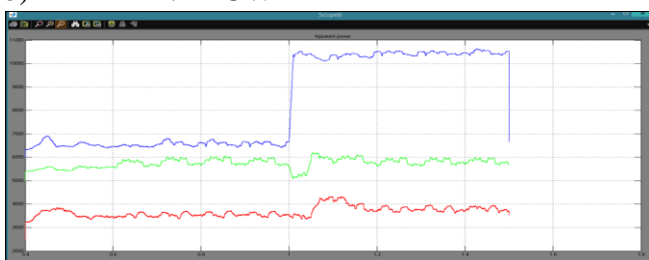

Powers of converters in islanded MG with ERPS with step change of maximum active power from RESs: p_1 , p_2 , p_3 , $p_{storage}$, converters active powers; p_{mppt1} , p_{mppt2} , p_{mppt3} , maximum active powers calculated from MPPT; q_1 , q_2 , q_3 , converters reactive powers; S_1 , S_2 , S_3 , converters apparent powers; and SN_1 , SN_2 , SN_3 , converters nominal apparent powers.

PROPORTIONAL REACTIVE POWER SHARING OUTPUTS

1) ACTIVE POWER

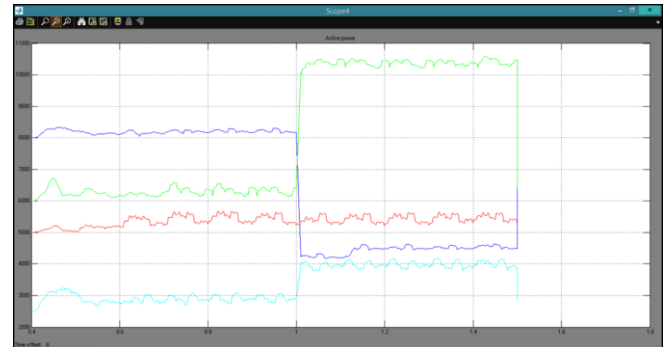

2) REACTIVE POWER

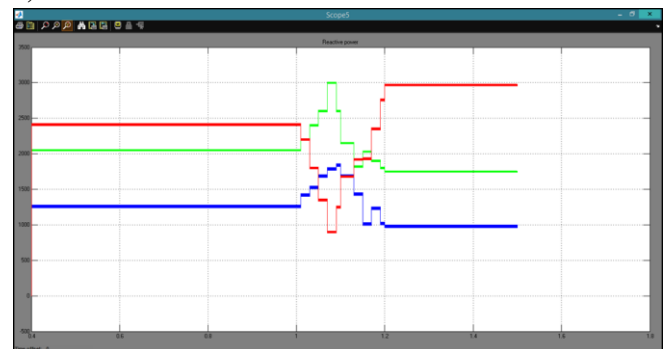

3) APPARENT POWER

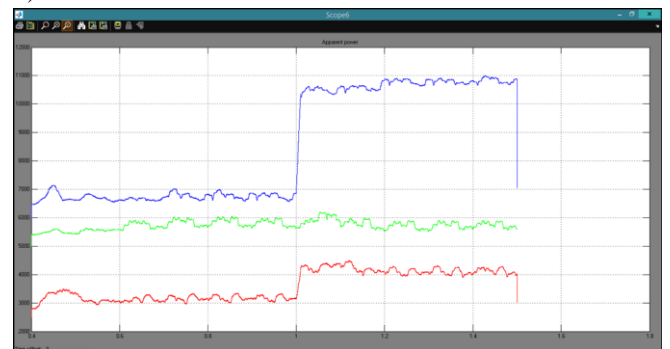

Powers of converters in islanded MG without reactive power management with step change of maximum active power from RESs: p_1 , p_2 , p_3 , $p_{storage}$, converters active powers; p_{mppt1} , p_{mppt2} , p_{mppt3} , maximum active powers calculated from MPPT; q_1 , q_2 , q_3 , converters reactive powers; S_1 , S_2 , S_3 , converters apparent powers; and SN_1 , SN_2 , SN_3 , converters nominal apparent powers.



CONCLUSION

MG is the advance system for RES integration with own control structure. Usually the hierarchical control is implemented with droop control in primary level. In islanded mode of operation there is the need to manage reactive power sharing and allow RESs work with maximum active power. Hence, the new reactive power sharing algorithm was proposed in this paper, based on the analysis of power sharing between converters in MG. The novel solution prevents the reactive power circulation and disconnection or damage of any converter in MG. Moreover, it allows to converters operation with MPPT, causing better exploitation of each RES and keeping apparent power of each unit below nominal level as long as possible. Because of short switching period of power electronics converters in RES, the algorithm was developed for implementation in hierarchical control structure, providing parallel calculations in each PCU. Simulation analysis was performed, where the three solutions of power control in islanded MG were compared what confirms the correct operation of developed algorithm and shows the advantage of proportional power sharing over others solution presented in literature.

REFERENCES

- [1] Y. Xinghuo, C. Cecati, T. Dillon, and M. G. Simões, "The new frontier of smart grids," *IEEE Ind. Electron. Mag.*, vol. 5, no. 3, pp. 49–63, Sep. 2011.
- [2] F. Blaabjerg and J. M. Guerrero, "Smart grid and renewable energy systems," in *Proc. Int. Conf. Elect. Mach. Syst. (ICEMS)*, Beijing, China, 2011, pp. 1–10.
- [3] European photovoltaic industry association. (May 2012). *Global Market Outlook for Photovoltaics until 2016*. [Online]. Available: http://www.epia.org/fileadmin/user_upload/Publications/Global-Market-Outlook-2016.pdf
- [4] Renewable energy policy network for the 21st century. *Renewables 2011 Global Status Report*. [Online]. Available: <http://www.ren21.net/REN21Activities/Publications/GlobalStatusReport/GSR2011/tabid/56142/Default.aspx>
- [5] Global wind energy council. *Global Wind Report: Annual Market Update 2011*. [Online]. Available: http://gwec.net/wp-content/uploads/2012/06/Annual_report_2011_lowres.pdf
- [6] The European wind energy association. (Feb. 2013). *Wind in Power, 2012 European Statistics*.
- [7] The European wind energy association. (Feb. 2012). *Wind in Power, 2011 European Statistics*.
- [8] ZPRIME and IEEE smart grid. (Nov. 2012). *Power Systems of the Future: The Case for Energy Storage, Distributed Generation and Microgrids*.
- [9] *Guide for Design, Operation, and Integration of Distributed Resource Island Systems with Electric Power Systems*, IEEE Standard 1547.4, 2011.
- [10] A. Engler and N. Soultanis, "Droop control in LV-grids," in *Proc. Int. Conf. Future Power Syst.*, Amsterdam, the Netherlands, 2005, pp. 1–6.

- [11] J. Kim, J. M. Guerrero, P. Rodriguez, R. Teodorescu, and K. Nam, "Mode adaptive droop control with virtual output impedances for an inverter-based flexible AC microgrid," *IEEE Trans. Power Electron.*, vol. 26, no. 3, pp. 689–700, Mar. 2011.