

Vigour Excellent Growth Using Hysteresis Voltage Manage Of Dvr

1.P.ARCHANA, 2.M.SREEVANI

1.Pg Scholar, Brilliant Grammar School Educational Society's Group Of Institutions-Integrated Campus Abdullapurmet (V),
HayathNagar (M), R.R Dt. Hyderabad – 501505

2.Asst.Professor, Brilliant Grammar School Educational Society's Group Of Institutions-Integrated Campus Abdullapurmet (V),
HayathNagar (M), R.R Dt. Hyderabad – 501505

ABSTRACT-

Power quality is one of the most important issues in present systems. Power quality problems like voltage sag, swell and harmonics are major concern of industrial and commercial electrical consumers this is due to large number of sophisticated electrical and, simple operation and variable switching electronics equipment such as computers, adjustable speed drives, programmable logic controllers and so forth. This equipment often requires high power supplies with high quality. Some devices are sensitive to the load voltage disturbances if these take up to several periods the circuit does not work. Various solutions are presented for this problem. One of the most effective methods is the use of Dynamic Voltage Restorer. The efficiency of the DVR is depends upon the control techniques involved in switching the inverter .In this paper hysteresis voltage control of DVR is used to improve the power quality problems. Hysteresis control has very fast transient response frequency. The performance of the

proposed method and achievement of desired compensation are confirmed by the results of the simulation using MATLAB/simulink.

I. INTRODUCTION:

Power quality is the delivery of sufficiently high grade electrical services to the customer. A power quality problem is an occurrence manifested as a non-standard voltage, current or frequency that results in failure or miss-operation of end user equipment's. Power distribution systems, ideally should provide customer with an uninterrupted flow of energy at smooth sinusoidal voltage at the Contracted magnitude level and frequency, but in practice distribution systems, have nonlinear loads, which affect the purity of waveform of supply. Some events both usual (e.g. Capacitor switching, motor starting) and unusual (e.g. Faults) could also inflict power quality problems. Faults at distribution level causes voltage sag or swell, which can cause sensitive equipment to fail as well as create a large current unbalance that could blow

fuses or trip breakers. Under heavy load conditions, a significant voltage drop may occur in the system. A dip is usually taken as an event lasting less than one minute when voltage decreases to between 0.1 and 0.9 p.u. (dip greater than 0.1 p.u. is usually treated as an interruption) or Voltage sag can occur at any instant of time, with amplitudes ranging from 10-90 % and a duration lasting for half cycle to one minute. These effects can be very expensive for the customer, from minor quality variation to production downtime and equipment damage. Voltage swell is defined as an increase in rms voltage or current at the power frequency for durations from 0.5 cycles to 1 min. If the supply voltage or load current decreases to less than 0.1 p.u for a period of time not more than one minute is known as interruption. It can be caused either by system faults, equipment failures or control malfunctions. Voltage support at a load can be achieved by reactive power injection at the load point of common coupling. The method for this is to install mechanically switched shunt capacitors in the primary terminal of the distribution transformer. The mechanical switching will be on a schedule, via the signals from a supervisory control and data acquisition (SCADA) system, with some timing

schedule, or without switching at all. The disadvantage in this method is that, high speed transients cannot be compensated. Some sag is not cleared within the limited time frame of mechanical switching devices. Transformer tapings may be used, but tap changing under load is costly. Initially for the improvement of power quality or reliability of the system FACTS devices like static synchronous compensator (STATCOM), static synchronous series compensator (SSSC), interline power flow controller (IPFC), and unified power flow controller (UPFC) etc are introduced. These types of FACTS devices are designed for the transmission system. But now a day as more attention is on the distribution system for the improvement of power quality, these FACTS devices are modified and known as custom power devices. The most effective type of CPD devices is considered to be dynamic voltage restorer (DVR). Power quality in the distribution system can be improved by using DVR, as assures pre-specified quality and reliability of supply. This prespecified quality of DVR may contain a combination of specification of following: low harmonic distortion in load voltage, low phase unbalance, no power interruptions, acceptance of fluctuations, and poor power factor loads without having

significant effect on the terminal voltage, low flicker at the load voltage, magnitude and also duration of overvoltage and under voltage within specified limits. DVR is still preferred because the SVC has no ability to control active power flow. Secondly DVR costs less compared to the UPS and it also require a high level of maintenance because batteries leak and have to be replaced every five years. Other reasons include that DVR is smaller in size and costs less compared to DSTATCOM.

II. DYNAMIC VOLTAGE RESTORER

Among the power quality problems like sag, swell, harmonic etc, voltage sag is the most severe disturbances in the distribution system. To overcome these problems the concept of custom power devices is introduced lately. One of those devices is the Dynamic Voltage Restorer (DVR), which is the most efficient and effective modern custom power device used in power distribution networks. DVR is the recently proposed series connected solid state device that injects voltage into the system in order to regulate the load side voltage. DVR is normally installed in a distribution system between the supply and the critical load feeder at the point of common coupling (PCC). Other than voltage sags and swells compensation, DVR can also having some

other features like line voltage harmonics compensation, fault current limitations and reduction of transients in voltage.

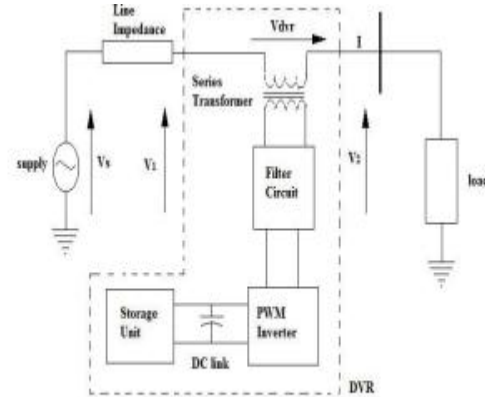

Fig 1: Schematic diagram of DVR

III. PRINCIPLE OF DVR OPERATION

A DVR is a solid state power electronics switching device consisting of either IGBT or GTO, a capacitor bank as an energy storage device and injection transformer which is linked in series between a distribution system and a load that shown. The basic idea of the DVR is to inject a controlled voltage generated by a forced commuted converter in a series to the bus voltage by means of an injecting transformer. A DC to AC inverter regulates this voltage by sinusoidal PWM technique. DVR will inject only a small voltage to compensate for the voltage drop of the injection transformer and device losses during normal condition. However, when voltage sag occurs in the distribution

system, the control system of the DVR calculates and synthesizes the voltage required to preserve output voltage to the load by injecting a controlled voltage with a certain magnitude and phase angle into the distribution system to the critical load. The DVR capable of generating or absorbing reactive power but the active power injection of the device must be provided by an external energy source or energy storage system. The response time of DVR is very short and is limited by the power electronics devices and the voltage sag detection time. The predictable response time is about 25 milliseconds, and which is less than some of the traditional methods of voltage correction such as tap-changing transformers.

A. DVR Power Circuit: The DVR consists of mainly a three-phase Voltage-Sourced Converter (VSC), a coupling transformer, harmonic filter, storage devices and a control system

B. Voltage Source Converter: A VSC is a power electronic system consists of a storage device and switching devices that can generate a sinusoidal voltage at any required frequency, phase angle and magnitude. It could be a 3 phase - 3 wires VSC or 3 phase - 4 wire VSC. For DVR application, the VSC is used to momentarily replace the supply generated by a forced commutated converter. This voltage is

injected in series to the bus voltage by means of an injection transformer. The amplitudes of the three injected phase voltages are controlled such as to remove any harmful effects of a bus fault to the load voltage VL. This means that any differential voltage caused by transient disturbances in the ac feeder will be compensated by an equivalent voltage generated by the converter and injected on the medium voltage level through the injection transformer. The DVR has three modes of operation which are: protection mode, standby mode, injection/boost mode. In protection mode, if the current on the load side exceeds a tolerable limit due to any fault or short circuit on the load, DVR will isolate from the system. In standby mode the voltage winding of the injection transformer is short circuited through converter.

C. Coupling Transformer Three single phase transformers are connected in series with the distribution feeder to couple the VSC (at the lower voltage level) to the higher distribution voltage level. It links the DVR system to the distribution network via the HV windings and transforms and couples the injected compensating voltages generated by the voltage source converters to the incoming supply voltage and also the Injection transformer serves the purpose of

isolating the load from the DVR system (VSC and control mechanism). Basic function is to step up and electrical isolation the ac low voltage supplied by the VSC to the required voltage. D. Harmonic Filter As DVR consist of power electronic devices, the possibility of generation self harmonics is there so harmonic filter is also become a part of DVR. The major purpose of harmonic filter is to keep the harmonic voltage content generated by the VSC to the acceptable level. E. Dc Charging Unit The dc charging circuit is used after sag compensation event the energy source is charged again through dc charging unit. It is also used to maintain dc link voltage at the nominal dc link voltage. F. Control system The aim of the control scheme is to maintain a balanced and constant load voltage at the nominal value under system disturbances. In this paper hysteresis voltage control is used for controlling the system.

IV. COMPENSATION TECHNIQUES IN DVR The voltage injection or compensation methods by means of a DVR mainly depend upon the limiting factors such as; DVR power ratings, different conditions of load, and different types of voltage sag There are different methods of DVR voltage injection which are a. Pre-sag compensation method b. In-phase

compensation method c. In-phase advanced compensation method

CONCLUSION This project has presented the power quality problems such as voltage dips, swells, sags distortions and harmonics. Compensation techniques of custom power electronic devices DVR is presented. The main function of a DVR is the protection of sensitive loads from voltage disturbances in the distribution system. It is observed that hysteresis control of DVR has fast transient response and reduces the problems of power quality such as voltage sag, swell and harmonics. The validity of recommended method is testified by results of the simulation in MATLAB SIMULINK. This characteristic makes it ideally suitable for low-voltage custom power applications.. It is observed that the capacity for power compensation and voltage regulation of DVR depends on the rating of the dc storage device.

REFERENCES

- [1]. N. G. Hingorani, "Introducing custom power," IEEE Spectr., vol. 32, no. 6, pp. 41–48, Jun. 1995.
- [2]. Chris Fitzer, Mike Barnes, Peter Green " Voltage Sag Detection Technique for a Dynamic Voltage Restorer " IEEE

Transactions on Power Delivery, Vol. 40, No. 1, pp. 203-212, January/February 2004

[3]. John Stones and Alan Collinson "Introduction to Power Quality" power engineering journal 2001 pages: 58 -64.

[4]. Bollen, M.H.J., "Voltage sags in three-phase systems" Power Engineering Review, IEEE, Vol. 21, Issue: 9, Sept. 2001, pp: 8 - 11, 15.

[5]. John Godsk Nielsen, FredeBlaabjerg and Ned Mohan "Control Strategies for Dynamic Voltage Restorer Compensating Voltage Sags with Phase Jump". Record of the 2005 IEEE Conference. pp.1267-1273.