



# Fuzzy Based Distributed Mppt Controller Of Grid Connected Pv System With Cascaded H-Bridge Inverter

**D Shiva Kumar**

M-tech Scholar

Department of Electrical & Electronics Engineering,  
Anurag Engineering College, Aushapur(v);Ghatkesar(M);  
Ranga Reddy (Dt); Telangana, India.  
Email:[dundhigalla.shiva@gmail.com](mailto:dundhigalla.shiva@gmail.com)

**M.L.R. Jyostna**

Assistant Professor (Experience: 8years)

Department of Electrical & Electronics Engineering,  
Anurag Engineering College, Aushapur(v);Ghatkesar(M);  
Ranga Reddy (Dt); Telangana, India.  
Email:[jyostna\\_muktevi@yahoo.co.in](mailto:jyostna_muktevi@yahoo.co.in)

**Abstract**—The inverters are categorized according to the configuration of the PV system, the configuration of the conversion stages within the inverter and whether they use transformers. After the introduction of the state of the art of inverters for PV systems with and without transformers, the paper focuses on some known problems and challenges for transformer less inverters. Topologies without transformers have big advantages like low weight, volume and cost. In addition they often reach higher efficiencies than topologies with transformers. Eliminating the leakage current is one of the most important issues for transformer less inverters in grid-connected photovoltaic system applications, where the technical challenge is how to keep the system common-mode voltage constant to reduce the leakage current.

To realize better utilization of PV modules and maximize the solar energy extraction, a distributed maximum power point tracking control scheme is applied to both single- and three-phase multilevel inverters, which allows independent control of each dc-link voltage. For three-phase grid-connected applications, PV mismatches may introduce unbalanced supplied power, leading to unbalanced grid current. The proposed concept can be implemented to fuzzy based distributed MPPT controlling technique with CHB inverter using Matlab/Simulink software.

**Index Terms**—cascaded multilevel inverter, distributed maximum power point (MPP) tracking (MPPT), modular, modulation Compensation.

## I. INTRODUCTION

In recent years, the efforts to spread the use of renewable energy resources instead of pollutant fossil fuels and other forms have increased. Photovoltaic systems offer the possibility of converting sunlight into electricity. The transformation of electricity through photovoltaic provides ease of installation, maintenance and become more affordable. One of the most common control strategies structures applied to decentralized power generator is based on power direct control employing a controller for the dc link voltage and a controller to regulate the injected current to the utility network. The system components and power control scheme are modeled in terms of dynamic behaviors. An improved MPPT converter with current compensation method for small-scaled PV-applications is presented in [1-3]. The proposed method implements maximum power point tracking (MPPT) by variable reference current which is

continuously changed during one sampling period. Lot of research has been done on maximum power point tracking of Photovoltaic cell. He introduced a new maximum power point tracking algorithm for photovoltaic arrays is proposed in [4]. The algorithm detects the maximum power point of the PV. The computed maximum power is used as a reference value of the control system. The proposed MPPT has several advantages: simplicity, high convergence speed, and independent on PV array characteristics. The many different techniques for maximum power point tracking of photovoltaic (PV) arrays are discussed in [5]. Paper should serve as a convenient reference for future work in PV power generation in [6].

The modular cascaded H-bridge multilevel inverter, which requires an isolated dc source for each H-bridge, is one dc/ac cascaded inverter topology. The separate dc links in the multilevel inverter make independent voltage control possible. As a result, individual MPPT control in each PV module can be achieved, and the energy harvested from PV panels can be maximized. Meanwhile, the modularity and low cost of multilevel converters would position them as a prime candidate for the next generation of efficient, robust, and reliable grid connected solar power electronics. A modular cascaded H-bridge multilevel inverter topology for single- or three-phase grid-connected PV systems is presented in this paper. The panel mismatch issues are addressed to show the necessity of individual MPPT control, and a control scheme with distributed MPPT control is then proposed. The distributed MPPT control scheme can be applied to both single and three-phase systems [7-9].

In addition, for the presented three-phase grid-connected PV system, if each PV module is operated at its own MPP, PV mismatches may introduce unbalanced power supplied to the three-phase multilevel inverter, leading to unbalanced injected grid current. To balance the three-phase grid current, modulation compensation is also added to the control system.

An improved perturbation and observation maximum power point tracking algorithm for PV arrays. Improved perturbation and observation method of Maximum Power Point Tracking control for photovoltaic power systems in

[10]. He explained about the perturbation observation method. Maximum photovoltaic power tracking an algorithm for rapidly changing atmospheric conditions explained in [11]. Evaluation of maximum power point tracking methods for grid connected photovoltaic systems discussed in [12]. In the maximum power point tracking method so many methods are available but he used the suitable tracker. The fuzzy inference is carried out by using Sugeno's method in [13]. So this is Sugeno, or TakagiSugeno-Kang, method of fuzzy inference. Introduced in 1985[9], it is similar to the Mamdani method in many respects. Hardware Implementation of Fuzzy Logic based Maximum Power Point Tracking Controller for PV System explained in [14]. The electric power supplied by a photovoltaic power generation systems depends on the solar irradiation and temperature. A Rule-Based Fuzzy Logic Controller for a PWM Inverter in Photo-voltaic Energy Conversion Scheme discussed in [15]. The modeling and simulation of the electric part of a grid connected photovoltaic generation system explained. This work proposed a fuzzy logic based controller to track MPPT in photovoltaic cell.

## II. SYSTEM DESCRIPTION

Modular cascaded H-bridge multilevel inverters for single and three-phase grid-connected PV systems are shown in Fig.1. Each phase consists of  $n$  H-bridge converters connected in series, and the dc link of each H-bridge can be fed by a PV panel or a short string of PV panels. The cascaded multilevel inverter is connected to the grid through  $L$  filters, which are used to reduce the switching harmonics in the current.

By different combinations of the four switches in each H-bridge module, three output voltage levels can be generated:  $-v_{dc}$ , 0, or  $+v_{dc}$ . A cascaded multilevel inverter with  $n$  input sources will provide  $2n + 1$  levels to synthesize the ac output waveform. This  $(2n + 1)$ -level voltage waveform enables the reduction of harmonics in the synthesized current, reducing the size of the needed output filters. Multilevel inverters also have other advantages such as reduced voltage stresses on the semiconductor switches and having higher efficiency when compared to other converter topologies.

## III. PANEL MISMATCHES

PV mismatch is an important issue in the PV system. Due to the unequal received irradiance, different temperatures, and aging of the PV panels, the MPP of each PV module may be different. If each PV module is not controlled independently, the efficiency of the overall PV system will be decreased.

To show the necessity of individual MPPT control, a five-level two-H-bridge single-phase inverter is simulated in MATLAB/SIMULINK. Each H-bridge has its own 185-W PV panel connected as an isolated dc source. The PV

panel is modeled according to the specification of the commercial PV panel from Astronergy CHSM-5612M.

Consider an operating condition that each panel has a different irradiation from the sun; panel 1 has irradiance  $S = 1000$  W/m<sup>2</sup>, and panel 2 has  $S = 600$  W/m<sup>2</sup>. If only panel 1 is tracked and its MPPT controller determines the average voltage of the two panels, the power extracted from panel 1 would be 133 W, and the power from panel 2 would be 70 W, as can be seen. Without individual MPPT control, the total power harvested from the PV system is 203 W.

However, the MPPs of the PV panels under the different irradiance. The maximum output power values will be 185 and 108.5 W when the  $S$  values are 1000 and 600 W/m<sup>2</sup>, respectively, which means that the total power harvested from the PV system would be 293.5 W if individual MPPT can be achieved. This higher value is about 1.45 times of the one before. Thus, individual MPPT control in each PV module is required to increase the efficiency of the PV system.

In a three-phase grid-connected PV system, a PV mismatch may cause more problems. Aside from decreasing the overall efficiency, this could even introduce unbalanced power supplied to the three-phase grid-connected system. If there are PV mismatches between phases, the input power of each phase would be different. Since the grid voltage is balanced, this difference in input power will cause unbalanced current to the grid, which is not allowed by grid standards. For example, to unbalance the current per phase more than 10% is not allowed for some utilities, where the percentage imbalance is calculated by taking the maximum deviation from the average current and dividing it by the average current.

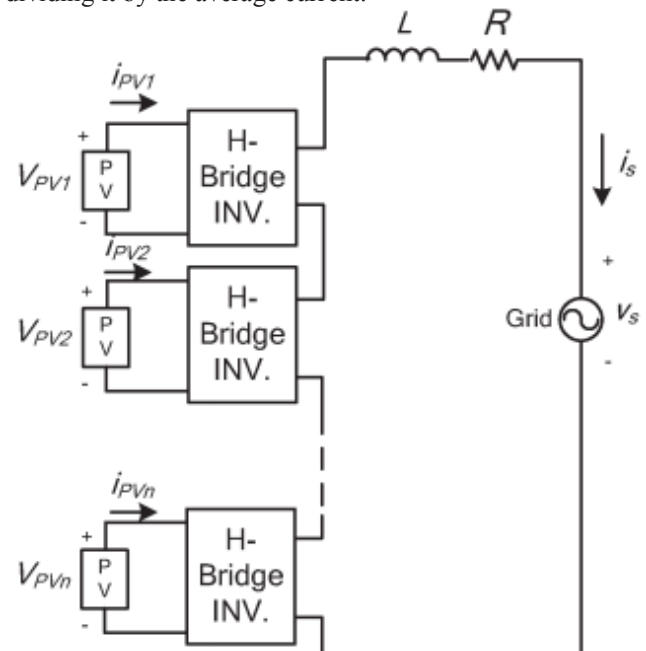

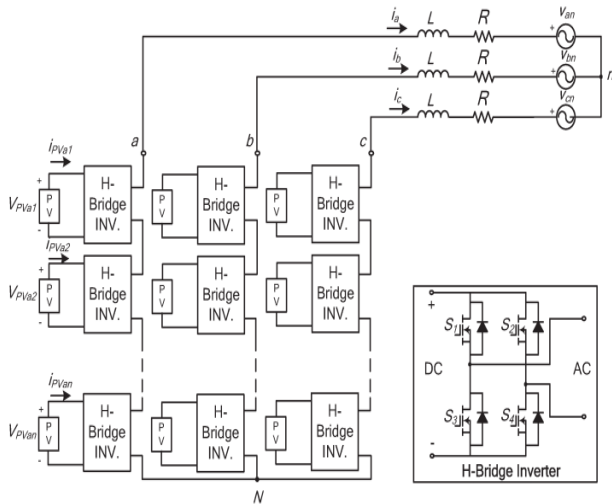

Fig. 1. Topology of the modular cascaded H-bridge multilevel inverter for grid-connected PV systems.

To solve the PV mismatch issue, a control scheme with individual MPPT control and modulation compensation is proposed. The details of the control scheme will be discussed in the next section.

#### IV. CONTROL SCHEME

##### A. Distributed MPPT Control

In order to eliminate the adverse effect of the mismatches and increase the efficiency of the PV system, the PV modules need to operate at different voltages to improve the utilization per PV module.

The separate dc links in the cascaded H-bridge multilevel inverter make independent voltage control possible. To realize individual MPPT control in each PV module, the control scheme proposed is updated for this application.

The distributed MPPT control of the three-phase cascaded H-bridge inverter is shown in Fig.2. In each H-bridge module, an MPPT controller is added to generate the dc-link voltage reference. Each dc-link voltage is compared to the corresponding voltage reference, and the sum of all errors is controlled through a total voltage controller that determines the current reference  $I_{dref}$ . The reactive current reference  $I_{qref}$  can be set to zero, or if reactive power compensation is required,  $I_{qref}$  can also be given by a reactive current calculator. The synchronous reference frame phase-locked loop (PLL) has been used to find the phase angle of the grid voltage. As the classic control scheme in three-phase systems, the grid currents in  $abc$  coordinates are converted to  $dq$  coordinates and regulated through proportional-integral (PI) controllers to generate the modulation index in the  $dq$  coordinates, which is then converted back to three phases.

The distributed MPPT control scheme for the single-phase system is nearly the same. The total voltage controller gives the magnitude of the active current reference, and a PLL provides the frequency and phase angle of the active current reference. The current loop then gives the modulation index.

To make each PV module operate at its own MPP, take phase  $a$  as an example; the voltages  $v_{dca2}$  to  $v_{dcan}$  are controlled individually through  $n - 1$  loops. Each voltage controller gives the modulation index proportion of one H-bridge module in phase  $a$ . After multiplied by the modulation index of phase  $a$ ,  $n - 1$  modulation indices can be obtained. Also, the modulation index for the first H-bridge can be obtained by subtraction. The control schemes in phases  $b$  and  $c$  are almost the same. The only difference is that all dc-link voltages are regulated through PI controllers, and  $n$  modulation index proportions are obtained for each phase.

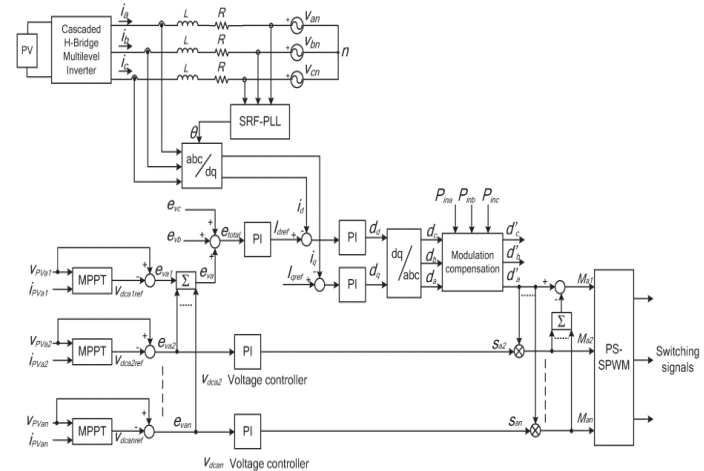

Fig. 2. Control scheme for three-phase modular cascaded H-bridge multilevel PV inverter.

A phase-shifted sinusoidal pulse width modulation switching scheme is then applied to control the switching devices of each H-bridge.

It can be seen that there is one H-bridge module out of  $N$  modules whose modulation index is obtained by subtraction. For single-phase systems,  $N = n$ , and for three-phase systems,  $N = 3n$ , where  $n$  is the number of H-bridge modules per phase. The reason is that  $N$  voltage loops are necessary to manage different voltage levels on  $N$  H-bridges, and one is the total voltage loop, which gives the current reference. So, only  $N - 1$  modulation indices can be determined by the last  $N - 1$  voltage loops, and one modulation index has to be obtained by subtraction.

Many MPPT methods have been developed and implemented. The incremental conductance method has been used in this paper. It lends itself well to digital control, which can easily keep track of previous values of voltage and current and make all decisions.

##### B. Modulation Compensation

As mentioned earlier, a PV mismatch may cause more problems to a three-phase modular cascaded H-bridge multilevel PV inverter. With the individual MPPT control in each H-bridge module, the input solar power of each phase would be different, which introduces unbalanced current to the grid. To solve the issue, a zero sequence

voltage can be imposed upon the phase legs in order to affect the current flowing into each phase. If the updated inverter output phase voltage is proportional to the unbalanced power, the current will be balanced.

Thus, the modulation compensation block, as shown in Fig. 3, is added to the control system of three-phase modular cascaded multilevel PV inverters. The key is how to update the modulation index of each phase without increasing the complexity of the control system. First, the unbalanced power is weighted by ratio  $r_j$ , which is calculated as

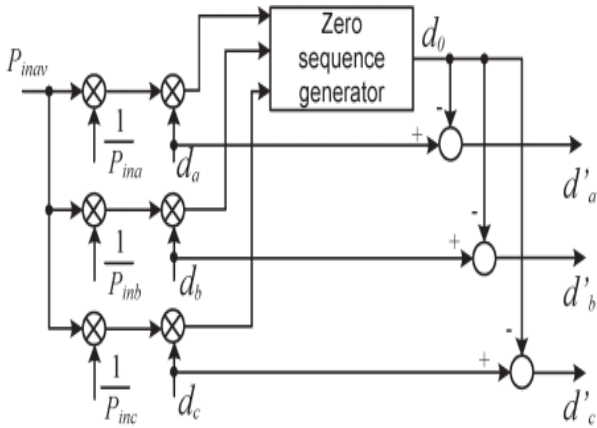

Fig. 3. Modulation compensation scheme.

$$r_j = \frac{P_{inav}}{P_{inj}} \quad (1)$$

Where  $P_{inj}$  is the input power of phase  $j$  ( $j = a, b, c$ ), and  $P_{inav}$  is the average input power.

Then, the injected zero sequence modulation index can be generated as

$$d_0 = \frac{1}{2} [\min(r_a \cdot d_a, r_b \cdot d_b, r_c \cdot d_c) + \max(r_a \cdot d_a, r_b \cdot d_b, r_c \cdot d_c)] \quad (2)$$

Where  $d_j$  is the modulation index of phase  $j$  ( $j = a, b, c$ ) and is determined by the current loop controller.

The modulation index of each phase is updated by

$$d'_j = d_j - d_0 \quad (3)$$

Only simple calculations are needed in the scheme, which will not increase the complexity of the control system. An example is presented to show the modulation compensation scheme more clearly. Assume that the input power of each phase is unequal

$$P_{ina} = 0.8 \quad P_{inb} = 1 \quad P_{inc} = 1 \quad (4)$$

### V FUZZY CONTROLLER

The control scheme consists of Fuzzy controller, limiter, and three phase sine wave generator for reference current generation and generation of switching signals. The peak value of reference currents is estimated by regulating the DC link voltage. The actual capacitor voltage is compared with a set reference value. The error signal is then processed through a Fuzzy controller, which contributes to zero steady error in tracking the reference current signal.

A fuzzy controller converts a linguistic control strategy into an automatic control strategy, and fuzzy rules are constructed by expert experience or knowledge database. Firstly, input voltage  $V_{dc}$  and the input reference voltage  $V_{dc-ref}$  have been placed of the angular velocity to be the input variables of the fuzzy logic controller. Then the output variable of the fuzzy logic controller is presented by the control Current  $I_{max}$ . To convert these numerical variables into linguistic variables, the following seven fuzzy levels or sets are chosen as: NB (negative big), NM (negative medium), NS (negative small), ZE (zero), PS (positive small), PM (positive medium), and PB (positive big) as shown in Figure 10.

The fuzzy controller is characterized as follows:

- 1) Seven fuzzy sets for each input and output;
- 2) Fuzzification using continuous universe of discourse;
- 3) Implication using Mamdani's 'min' operator;
- 4) De-fuzzification using the 'centroid' method.

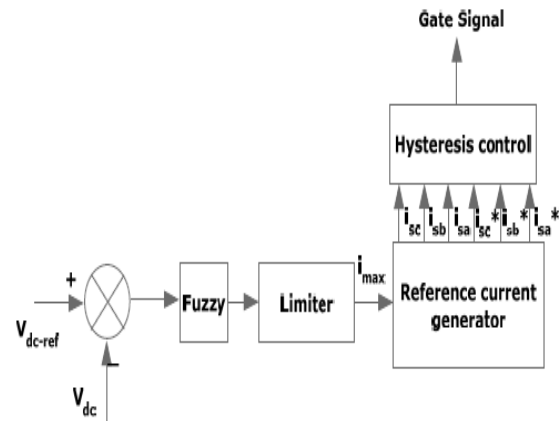
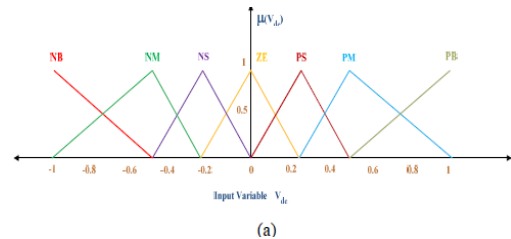

Fig 4 Conventional fuzzy controller





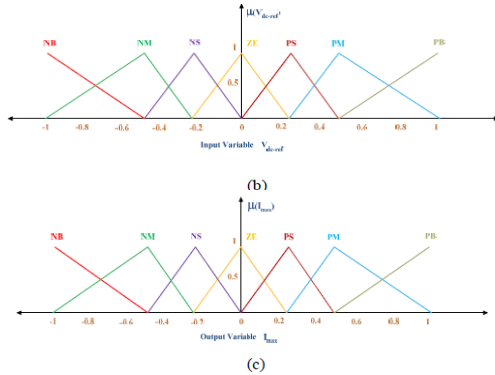

Fig 5(a) Input Vdc normalized membership function; (b) Input Vdc-ref Normalized Membership Function; (c) Output Imax Normalized Membership Function

**Fuzzification:** the process of converting a numerical variable (real number) convert to a linguistic variable (fuzzy number) is called fuzzification.

**De-fuzzification:** the rules of FLC generate required output in a linguistic variable (Fuzzy Number), according to real world requirements, linguistic variables have to be transformed to crisp output (Real number).

**Database:** the Database stores the definition of the membership Function required by fuzzifier and defuzzifier.

**Rule Base:** the elements of this rule base table are determined based on the theory that in the transient state, large errors need coarse control, which requires coarse input/output variables; in the steady state, small errors need fine control, which requires fine input/output variables. Based on this the elements of the rule table are obtained as shown in Table 1, with 'Vdc' and 'Vdc-ref' as inputs.

Table 1. Rule base.

$\frac{V_{dc-ref}}{V_{dc}}$	NB	NM	NS	Z	PS	PM	PB
NB	NB	NB	NB	NB	NM	NS	Z
NM	NB	NB	NB	NM	NS	Z	PS
NS	NB	NM	NM	NS	Z	PS	PM
Z	NB	NM	NS	Z	PS	PM	PB
PS	NM	NS	Z	PS	PM	PB	PB
PM	NS	Z	PS	PM	PB	PB	PB
PB	Z	PS	PM	PB	PB	PB	PB

VI MTALAB/SIMULATION RESULTS

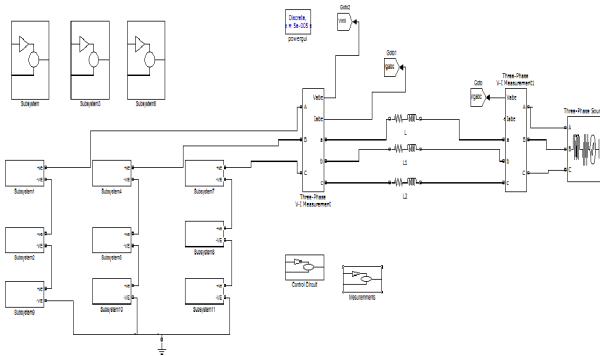

Fig 6 Simulation model of modular cascaded distributed MPPT control based grid connected system

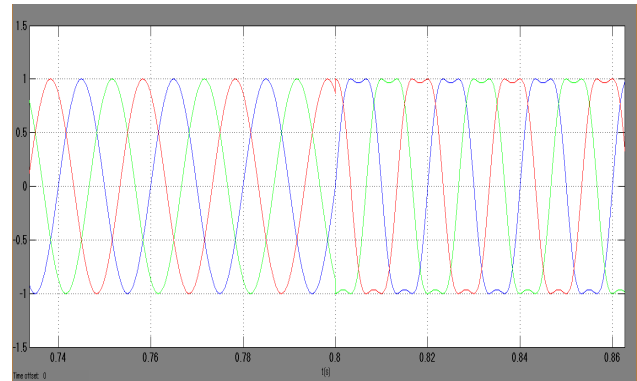

Fig 7 Simulation waveform of after and before compensation

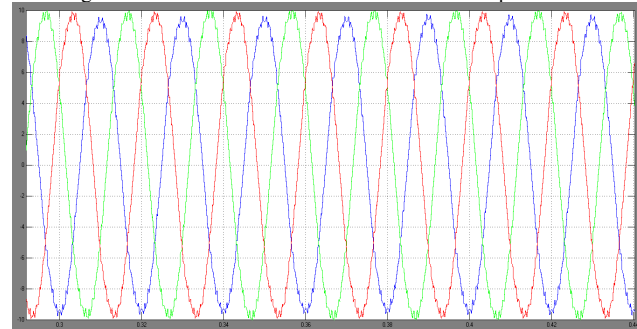

Fig 8 Simulation waveform of grid current

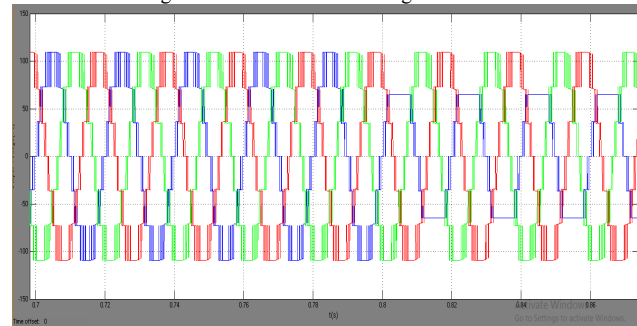

Fig 9 Simulation waveform of output MLI voltage

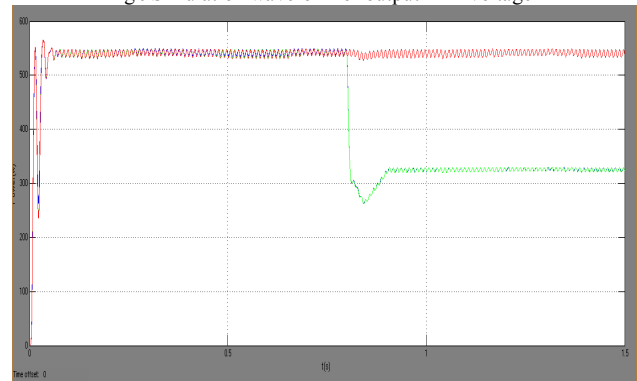

Fig 10 Simulation waveform of Power extracted from PV panel

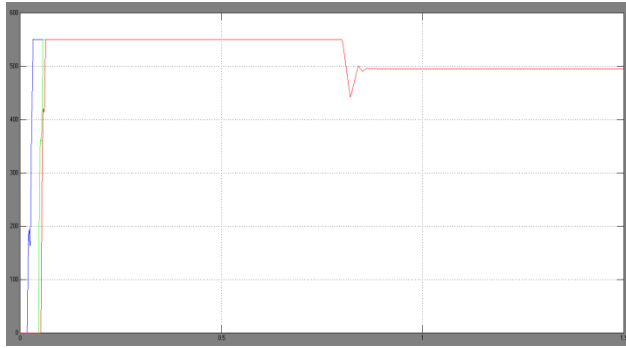

Fig 11 Simulation waveform of output grid power

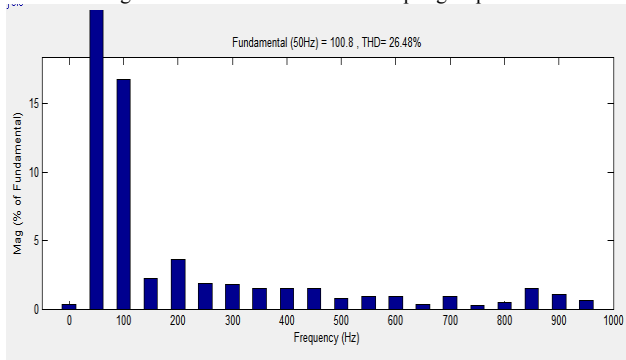

Fig 12 Simulation waveform of harmonic analysis

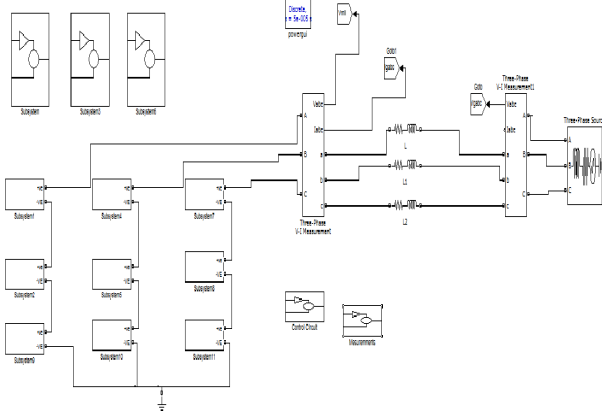

Fig 13 Simulation waveform of fuzzy based distributed MPPT MLI grid connected system

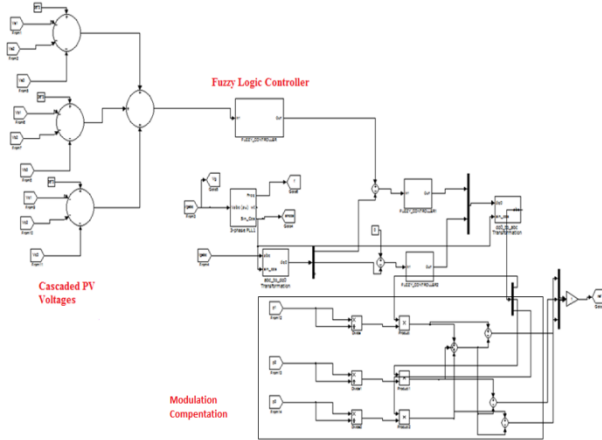

Fig 14 Simulation waveform of Fuzzy control circuit diagram

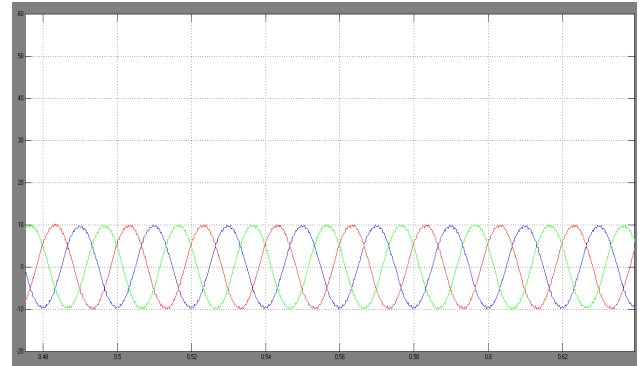

Fig 15 Simulation waveform of grid current

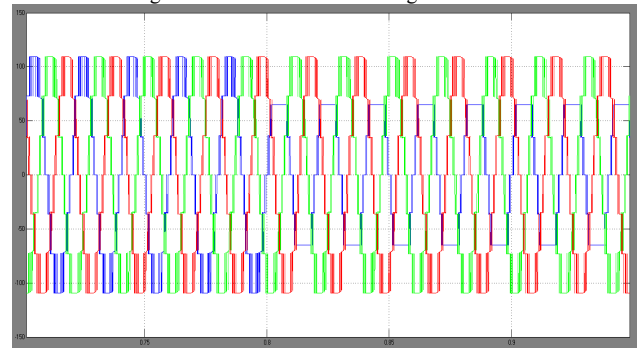

Fig 16 Simulation waveform of Inverter voltage

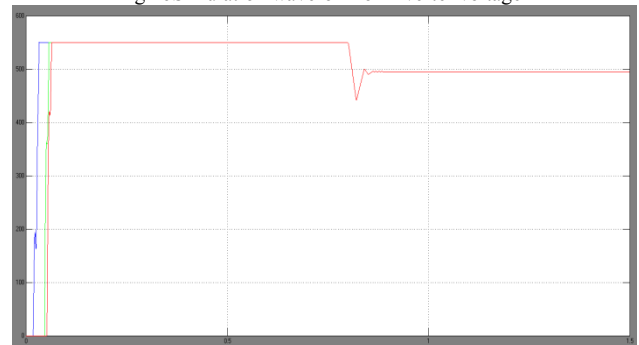

Fig 17 Simulation waveform of Three phase Output power

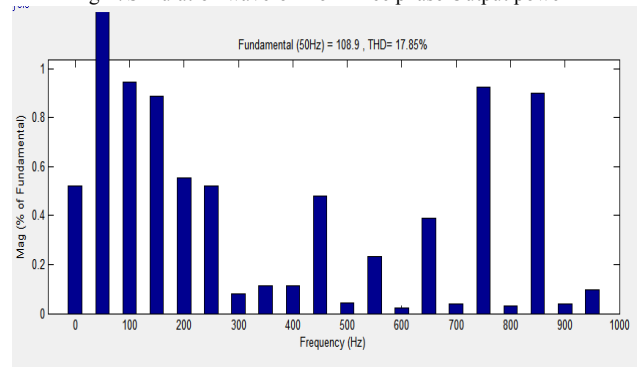

Fig 18 Simulation waveform of Harmonic analysis

### VI.CONCLUSION

The purpose of this paper is to study the harmonic profile of Grid connected PV system for different MPPT methods including perturbation & observation incremental conductance and Fuzzy logic controller. The PV simulation system used in this paper is set up under

Matlab/Simulink environment. After accomplishing the model of PV modules, the models of Multi level inverter and MPPT systems are combined with it to complete the PV simulation system with the MPPT functions. The proposed fuzzy MPPT sets the optimum DC bus voltage reference for the inverter without the need for a dc-dc converter. The control of the active and reactive power is done using a PI controller. Fuzzy based three phase single stage grid connected PV system has been proposed. The harmonics are eliminated by the double tuned resonant filter. The power extracted from the PV array increased by the fuzzy based MPPT which develop the system performance in varying weather condition.

### REFERENCES

- [1] J. M. Carrasco et al., "Power-electronic systems for the grid integration of renewable energy sources: A survey," *IEEE Trans. Ind. Electron.*, vol. 53, no. 4, pp. 1002–1016, Jun. 2006.
- [2] S. B. Kjaer, J. K. Pedersen, and F. Blaabjerg, "A review of single-phase grid connected inverters for photovoltaic modules," *IEEE Trans. Ind. Appl.*, vol. 41, no. 5, pp. 1292–1306, Sep./Oct. 2005.
- [3] M. Meinhardt and G. Cramer, "Past, present and future of grid connected photovoltaic- and hybrid power systems," in *Proc. IEEE PES Summer Meet.*, 2000, vol. 2, pp. 1283–1288.
- [4] M. Calais, J. Myrzik, T. Spooner, and V. G. Agelidis, "Inverter for singlephase grid connected photovoltaic systems—An overview," in *Proc. IEEE PESC*, 2002, vol. 2, pp. 1995–2000.
- [5] J. M. A. Myrzik and M. Calais, "String and module integrated inverters for single-phase grid connected photovoltaic systems—A review," in *Proc. IEEE Bologna Power Tech Conf.*, 2003, vol. 2, pp. 1–8.
- [6] F. Schimpf and L. Norum, "Grid connected converters for photovoltaic, state of the art, ideas for improvement of transformer less inverters," in *Proc. NORPIE*, Espoo, Finland, Jun. 2008, pp. 1–6.
- [7] B. Liu, S. Duan, and T. Cai, "Photovoltaic DC-building-module-based BIPV system—Concept and design considerations," *IEEE Trans. Power Electron.*, vol. 26, no. 5, pp. 1418–1429, May 2011.
- [8] L. M. Tolbert and F. Z. Peng, "Multilevel converters as a utility interface for renewable energy systems," in *Proc. IEEE Power Eng. Soc. Summer Meet.*, Seattle, WA, USA, Jul. 2000, pp. 1271–1274.
- [9] H. Ertl, J. Kolar, and F. Zach, "A novel multicell DC-AC converter for applications in renewable energy systems," *IEEE Trans. Ind. Electron.*, vol. 49, no. 5, pp. 1048–1057, Oct. 2002.
- [10] S. Daher, J. Schmid, and F. L. M. Antunes, "Multilevel inverter topologies for stand-alone PV systems," *IEEE Trans. Ind. Electron.*, vol. 55, no. 7, pp. 2703–2712, Jul. 2008.
- [11] G. R. Walker and P. C. Sernia, "Cascaded DC-DC converter connection of photovoltaic modules," *IEEE Trans. Power Electron.*, vol. 19, no. 4, pp. 1130–1139, Jul. 2004.
- [12] E. Roman, R. Alonso, P. Ibanez, S. Elorduizapatarietxe, and D. Goitia, "Intelligent PV module for grid-connected PV systems," *IEEE Trans. Ind. Electron.*, vol. 53, no. 4, pp. 1066–1073, Jun. 2006.
- [13] F. Filho, Y. Cao, and L. M. Tolbert, "11-level cascaded H-bridge gridtied inverter interface with solar panels," in *Proc. IEEE APEC Expo.*, Feb. 2010, pp. 968–972.
- [14] C. D. Townsend, T. J. Summers, and R. E. Betz, "Control and modulation scheme for a cascaded H-bridge multi-level converter in large scale photovoltaic systems," in *Proc. IEEE ECCE*, Sep. 2012, pp. 3707–3714.
- [15] B. Xiao, L. Hang, and L. M. Tolbert, "Control of three-phase cascadedvoltage source inverter for grid-connected photovoltaic systems," in *Proc. IEEE APEC Expo.*, Mar. 2013, pp. 291–296.

### Author's profile:



D SHIVA KUMAR, Received B.Tech. in Electrical and Electronics Engineering From Anurag Engineering College in 2014, Currently Pursuing M.Tech. (Electrical power systems) From Anurag college of engineering, Aushapur(v), Ghatkesar(m), R.R DIST, Telangana.



M.L.R.JYOSTNA, At present she is an Assistant Professor in the department of EEE in Anurag college of engineering, Ranga Reddy Telengana, India. Received B. Tech.degree in EEE from Acharya Nagarjuna University in 2006. Received M.Tech. degree in Electrical Power Systems, JNTUH, 2013, HYD