

IOT based Smart Grid to remotely monitor and control Renewable Energy Sources

1. MOHAMED AFZAL, 2. MR. N. KARTHEEK

1PG Scholar, Department of ECE, SVS INSTITUTE OF TECHNOLOGY (Approved by AICTE, New Delhi & Affiliated to JNTU, Hyderabad & ISO 9001:2008 certified) BHEEMARAM(V), HASANPARHY(M), WARANGAL (Dt). T.S. India -506015.

[Email id: mohamedshahinsha1@gmail.com](mailto:mohamedshahinsha1@gmail.com)

2. Assistant Professor, Department of ECE, SVS INSTITUTE OF TECHNOLOGY (Approved by AICTE, New Delhi & Affiliated to JNTU, Hyderabad & ISO 9001:2008 certified) BHEEMARAM(V), HASANPARHY(M), WARANGAL (Dt). T.S. India -506015.

[Email id: kartheeknagaturi@gmail.com](mailto:kartheeknagaturi@gmail.com)

ABSTRACT: Web of Things is a new information processing and acquisition method, that is been widely used in intelligent transportation, environmental monitoring and other fields. The WoT is an important technical mean to the development of smart grid and security smart grid. WoT technology can effectively combine the infrastructure resources in increase the level of power system information, and improve the utilization efficiency of infrastructures in the existing power system. The urgency of its applications in smart grid are pointed out by concept of smart grid and WoT are described. The construction of smart grid which is based on Web of things are made, and implementation in typical application including Solar power prediction, condition monitoring of overhead transmission lines, power monitoring, smart home and asset management.[2]

KEYWORDS: Power Prediction, Smart Home, Security Smart Grid, Web Of Things Technology.

I. INTRODUCTION TO SMART GRID AND INTERNET OF THINGS

The WOT concept was coined by a member of the Radio Frequency Identification (RFID) development community in 1999, and it has become more relevant to the practical world largely because of the growth of mobile devices, embedded and cloud computing and data analytics. “Web of Things” refers to the general idea of things, especially everyday objects, which

are readable, recognizable, locatable, addressable, and/or controllable via the Internet, irrespective of the communication means (whether via RFID, wireless LAN, wide- area networks, or other means). Every day we encounter objects include not only the electronic devices but the products of higher technological development such as vehicles and equipment but things that we do not ordinarily think of as electronic at all - such as food and clothing.[1] The “things”

of the real world shall integrate into the virtual world, enabling anytime, anywhere connectivity. The number of everyday physical objects and devices connected to the Internet was around 12.5 billion in 2010. The number of value expected to double to 25 billion in 2015 as the number of more smart devices per person increases, as far as to a further 50 billion by 2020. The impact and value that IOT brings to our daily lives become more prevalent as Smart devices

connected in the IOT landscape. Better decisions such as taking the best routes to work or choosing their favorite restaurant is done by people. The Web of Things vision to successfully emerge, the computing criterion will need to go beyond traditional mobile computing scenarios that use smart phones and portables, and evolve into connecting everyday existing objects and embedding intelligence into our environment.



Fig 1: WOT Anything, Anywhere, Anytime. The data sources on shared networks improves nationwide planning, promotes better coordination between agencies and facilitates quicker responsiveness to emergencies and disasters, it very effective.

WOT brings about abundant business benefits from improved management and tracking of assets and products cost savings achieved through the optimization of equipment and resource usage.

Web of Things, namely “the Internet in which all the things connected to each other”, is the tremendous extension and expansion of Internet network. The protocols, with WOT key technologies: radio frequency identification technology (RFID), sensor technology, smart technology and nanotechnology, the communication information can be exchanged, and the intelligent recognition, positioning, tracking, monitoring and management can be easily managed.

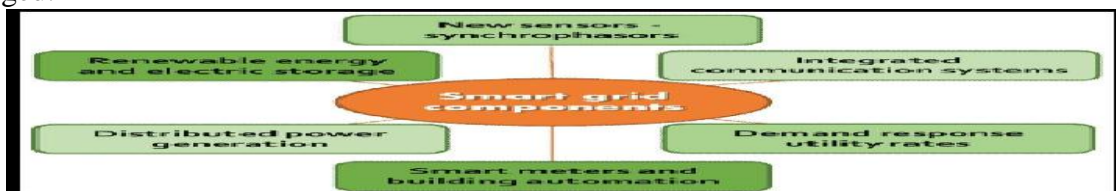

Fig 2: Smart Grid Component

What happens when everyday ordinary objects have inter-connected microchips inside them is the WoT. The microchips not only keep track of other objects, but also help in many of these devices sense their surrounding and report it to other machines as well as to the human's being. Two modes of communication in the WoT are thing to person and thing-to-thing communication.[5]

The highly integrated with advanced sensor measurement technology, information and communication technology, analysis of the decision-making technology, automatic control technology, and energy power technology is smart grid and power grid. By compared in traditional and smart grid, smart grid has been improved distinctly in the optimization of power control, the flexibility of grid structure, optimizing the allocation of resources, and improving the power quality of services and increase in efficiency of power.

II. LITERATURE REVIEW

The Web of Things is a concept that characterizes the way in which objects are assigned identifiers and interconnected with other objects that produce the same data so that they can communicate and be tracked, providing a mesh of related data (Haller and Karnouskos, 2009) [1]. The literature states that while this were a theorized as the "Future Internet", technological advances have led to its application in business, medical, household. The Carnot Institute (2011) cited hardware advances in

"microelectronics for smart autonomous communication enabled objects" as the chief enabler for WoT along with distributed intelligence and human interaction model. The Internet of Things (IOT) is happens when everyday ordinary objects have inter-connected microchips inside them. These microchips help not only keep track of other objects, but many of these devices sense their surrounding and report it to other machines as well as to the humans. Also called M2M, standing for Machine to Machine, Machine to Man, Man to Machine or Machine to Mobile, the WOT intelligently connects humans, devices and systems, (Internet of Things in 2020, 2008)[5]. Analysts describe two distinct modes of communication in the IoT: thing to person and thing-to-thing communication (Raunio, 2009). Thing-to-person and person-to-thing communications encompass a number of technologies and applications, wherein people interact with things and vice versa, including remote access to objects by humans, and objects. Thing-to thing communications encompasses technologies and applications wherein everyday objects and infrastructure interact with the human beings. The objects can monitor other objects, take corrective actions and notify or

prompt humans as required.

The CASAGRAS defines the WOT as (Casagras, 2011):“A global network, linking physical and virtual objects through the exploitation of data capture and communication capabilities. This includes existing and evolving Internet and network developments. It offer specific object-identification, sensor and connection capability as the basis for development of independent federated services and applications these will be characterized by a high degree of autonomous data capture, event transfer, network connectivity and inter operability”. The WOT means “A world-wide network of interconnected objects, uniquely addressable, based on standard communication protocols” (Web of Things in, 2008). [4]

The GPRS module is (it can operate in 4 different bands, meaning it supports any cellular provider), making it able to work all over the world (RESCATAME, 2011).[6]

III. METHODOLOGY

The use of two different Energy sources , one is the main power supply from grid and the other one is Renewable energy supply and by making use of this renewable energy source provides the reliable power supplies to the consumers. As WoT architecture will switch between the two power sources according to the consumption by monitoring the power consumption by different loads at home. The power generated using renewable energy sources, such as photovoltaic (PV) solar panels and wind turbines, is variable depending upon the season, weather conditions and the period of any day. CT Coil current sensors are used to sense current flow of the individual supply which can be measured. This can effectively reduce power loss, low operating temperature, increase reliability.

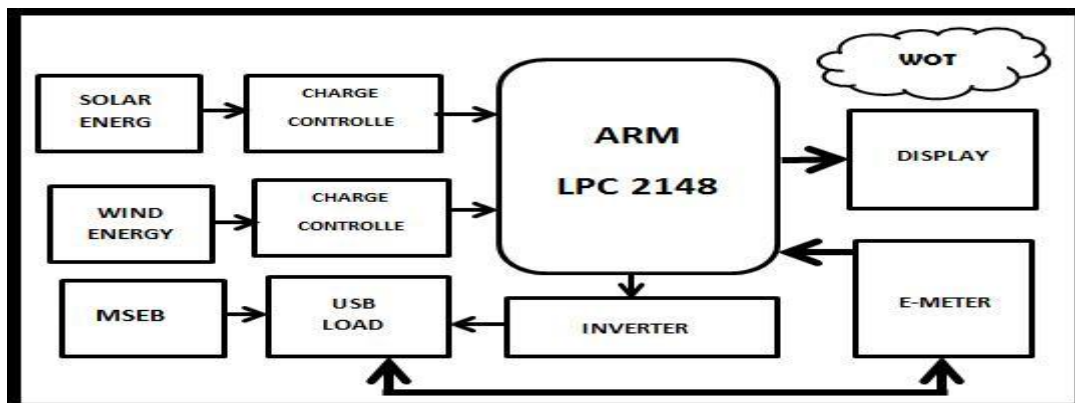

Fig 3: Block Diagram of WoT and energy management system.

The data collected will regularly update in the cloud by the GPRS/GSM

modem. Web of Things platform with initial applications tailored to building energy

insight control. Once the data stored in the cloud using the Web service authenticated user can access data from anywhere in the world and can analyze the power consumption, he just need an internet connection for this and no any data.

The documents which are necessary is verified and after proper verification the installation is carried out by professional to include the home in the smart grid. The status of his application processing will be tracked by the user on the login screen by WoT. The application details on this page can be print after application has been processed. An index page which gives him a couple of options after user logging in enters.

One of benefit is there, options is to check for the average power Consumption of a particular home. The user gets help to check his energy needs and accordingly plan

the scheduling of his power sources. The user can use to identify his consumption day-wise, month-wise or year-wise. The compare between consumption data and consumption data of other times by means of comparison of average consumption data. Based on the power consumption data, the user plans ahead how and when to use its energy source using.

The web services user to allow configure the switching of energy sources according to a preplanned schedule. It is possible only one user is allowed to access at a time. After all data which is consume is display on IoT and display separately i.e. renewable and non renewable. The billing of power consumption of MSEB is done online by IoT. The equipments which are carry on after we are not present at home is switch off using WoT.

IMPLEMENTATION:

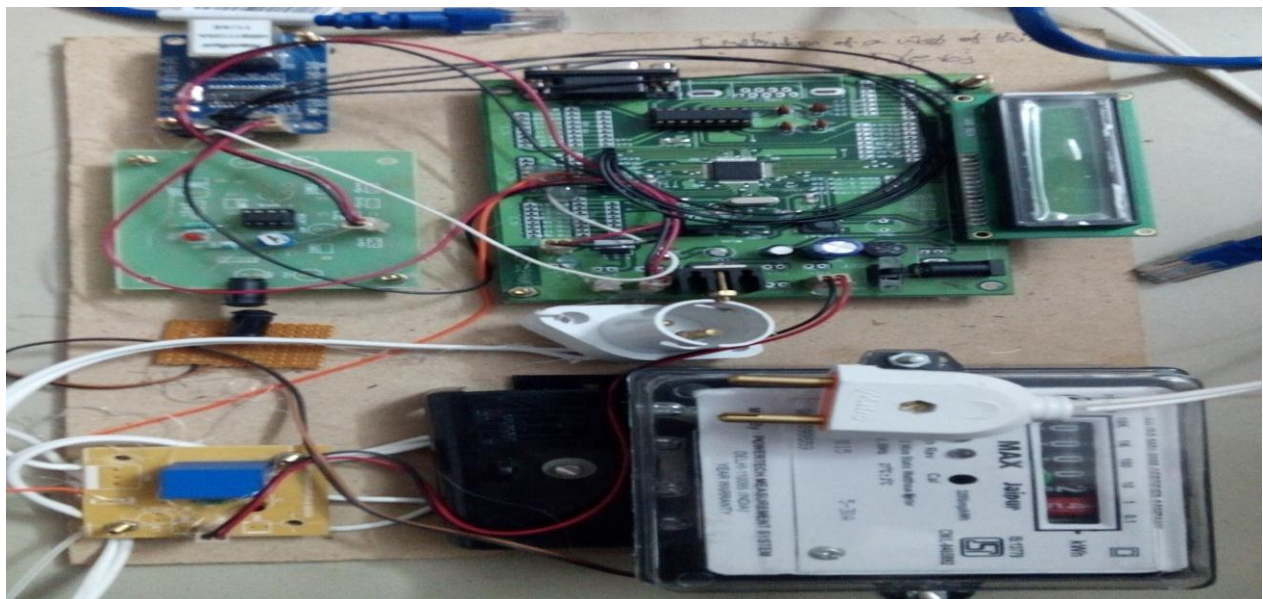

The user is authenticated as a user after he registers himself for a connection, by Applying for a new connection on the login

screen. Proper verification an installation is carried out by professional to include the home in the smart grid. One of these options

is to check for the power Consumption of a particular home. This supports the user to check his energy needs and plan the scheduling of his power sources. The user can check out his consumption day, month or year-wise. The data consumption can be compared to consumption data of other times by means of comparison of average consumption data. Based on the average power consumption data ,the user plans how and when to use its energy sources using the IOT .The IOT services allows the user to configure the switching of energy sources according to a preplanned schedule.

Only one user is allowed to access at a one time. This configuration has direct connection to the embedded boards through IOT. The control embedded change the source by controlling the source changers which are connected to the smart grid power supplies of individual homes. All data consumption is check, data which used by MSEB is pay online. It Provide efficient, comfortable, safe and convenient, environmentally friendly living environment for people, which Sets system, service, management as a whole.

CONCLUSION

The designed system is easy to implement

and very customizable according to needs. It provides effective techniques of using our renewable energy resources which would otherwise have been underutilized. It gives finally a very effective method for implementing green energy concept on a larger scale.

REFERENCES

- [1]. Saswat Mohanty, Bikash Narayan Panda “Implementation of a Web of Things based Smart Grid to remotely monitor and control Renewable Energy Sources,”*volume: 2, 2014 IEEE Students’ Conference on Electrical, Electronics and Computer Science.2014*
- [2].Andreas Kamilaris_, Yiannis Tofisy, Chakib Bekaraz, Andreas Pitsillides_ and Elias “ Energy-Aware Smart Homes to the Smart Grid By IOT ”, *Department of Computer Science Networks Research Laboratory University of Cyprus (2012).*
- [3].Jayavardhana Gubbia, Rajkumar Buyyab,, Slaven Marusic a, Marimuthu Palaniswami a “ Internet of Things (IoT): A vision, architectural elements, and future directions,” *Future Generation Computer Systems 29 1645–1660 (2013).*
- [4].Antonio J. Jara1_, Latif Ladid2, and Antonio “The Internet of Everything

through IPv6: An Analysis of Challenges, Solutions and Opportunities,” *University of Applied Sciences Western Switzerland (HES-SO) Vice-chair, IEEE ComSoc IoT.*

[5].Liu Hua¹, Zhang Junguo¹, Lin Fantao² “ Internet of Things Technology and its Applications in Smart Grid ,” *Indonesian Journal of Electrical Engineering Vol.12, No.2, , pp. 940 ~ 946 ,February 2014.*

[6].Vedang Ratan Vatsa, Gopal Singh “ A Literature Review on Internet of Things (IoT),” *International Journal of Computer Systems (ISSN: 2394-1065), Volume 02– Issue 08, August, 2015.*

[7].Somayya Madakam, R. Ramaswamy, Siddharth Tripathi “Internet of Things (IoT) :A literature review,” *Journal of Computer and Communications, 2015, 3, 164-173 .*

[8].Md Masud Rana ,” An Overview of Distributed Micro grid State Estimation and Control for Smart Grids,” *ISSN 1424-8220, 2015.*

[9].Faysal Nayan¹, Md. Aminul Islam², Shifat Mahmud³ “Feasibility Study of Smart Grid in Bangladesh ,” *Energy and Power Engineering, 5, 1531-1535, 2013 .*

[10].Meraka Institute “Adopting the internet of things technologies in environmental Management,” *2012 International*

Conference on Environment Science and Engineering IPCBEE vol.3 2(2012) © (2012)IACSIT .