

Coal Mining Safety Monitoring Using WSN

SILUVERU BHAVANI*, M. SRUJANA**

PG Scholar*, Associate Prof**

Department of Electronics & Communication Engineering

SVS INSTITUTE OF TECHNOLOGY (Approved by AICTE, New Delhi & Affiliated to JNTU, Hyderabad & ISO 9001:2008 certified) BHEEMARAM(V), HASANPARHY(M), WARANGAL (Dt). T.S. India -506015.

Abstract-The main purpose was to provide an implementable design scenario for underground coal mines using wireless sensor networks (WSNs). The main reason being that given the intricacies in the physical structure of a coal mine, only low power WSN nodes can produce accurate surveillance and accident detection data. The work mainly concentrated on designing and simulating various alternate scenarios for a typical mine and comparing them based on the obtained results to arrive at a final design. In the Era of embedded technology, the Zigbee protocols are used in more and more applications. Because of the rapid development of sensors, microcontrollers, and network technology, a reliable technological condition has been provided for our automatic real-time monitoring of coal mine. The underground system collects temperature, humidity and methane values of coal mine through sensor nodes in the mine; it also collects the number of personnel inside the mine with the help of an IR sensor, and then transmits the data to information processing terminal based on ARM.

Keywords- Wireless Sensor Network (Zigbee), Embedded Board, ARM.

I. INTRODUCTION

The existing monitoring systems underground of coal mine mostly use cable network and very often of them use wireless sensor networks but can't personnel in the mines. When an accident happened, especially explosion, the sensors and cables usually were damaged fatally, and couldn't provide information for rescue search and detection events. In this application, Wireless sensor network can solve the key issues of communication bandwidth, mobile data transmission, staff orientation, working surface real-time monitoring, synchronization monitoring and so on. The WSNs have been lately successfully employed in various applications ranging from area monitoring, landslide detection to health monitoring and other bio-medical applications. The sensor nodes in the underground section will send the collected data to an embedded network controller based on ARM kernel. And then the controller receives the data and sends them to the ground PC by the use of Zigbee protocol. With the concept of M2M (machine to machine, machine to mobile, mobile to machine), the ground PC saves the parameter values and the microcontroller transmits the monitoring results to the mobile phones through GPRS, and the abnormal situations can be dealt with in time. In addition, the mobile inquiring service can also be supported.

- 1.To check the presence of methane gas inside the mine
- 2.To check the water level of

nearby river continuously

- 3.To save the life of worker who may die by numerous explosion taking place inside the mine
- 4.To provide whole interconnection, Wirelessly using different topology

III. DESIGN AND PROPOSAL OF PROJECT

A. Under Ground Section:

In the underground section, the parameters temperature, humidity and gas are measured by means of respective sensors and the output voltage measured by them is directly connected to the ADC of the ARM, as the output voltage never exceeds 5V, there is no need of connecting a signal conditioning circuit. The number of people inside the coalmine is monitored by the help of IR sensor. During a hazard this information will be useful to know whether there are any people remained inside the coalmine. Information regarding the safety measures like wearing oxygen helmets etc., will be already given to the provide the details of the num workers so that they can save their life. If any the received parameters are beyond the ultra limit, then a Buzzer will be ON, giving warning to the people. The parameters are displayed on the LCD screen and as well as transmitted to the Ground Section through the Zigbee Transceiver.

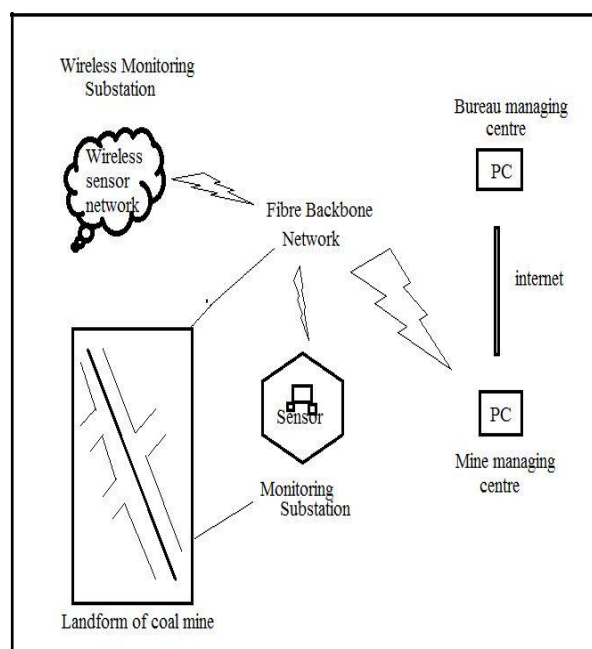

II. AIM OF PROJECT

Fig 1: Mine Safety System using Wired and Wireless Monitoring

B. Ground Section:

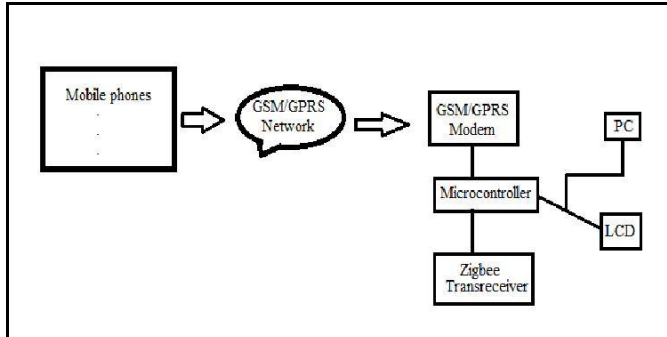

B.I. Flow Chart Ground Section:

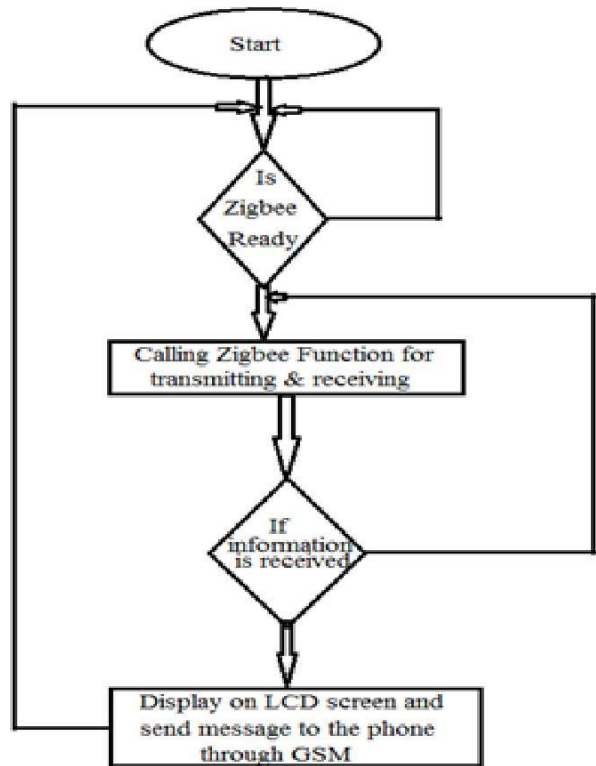

In the Ground Section, the Zigbee Transceiver receives the information and sends to the ARM controller. The LCD connected to the controller displays the information in the Ground Section. The controller is connected to the GSM modem through RS232. A number of mobile phones to which the data has to be sent is connected to the modem through GSM network. In addition the controller is connected to PC; the measured values are continuously displayed and stored in the PC for future use.

A I. Flow chart for Under Ground Section:

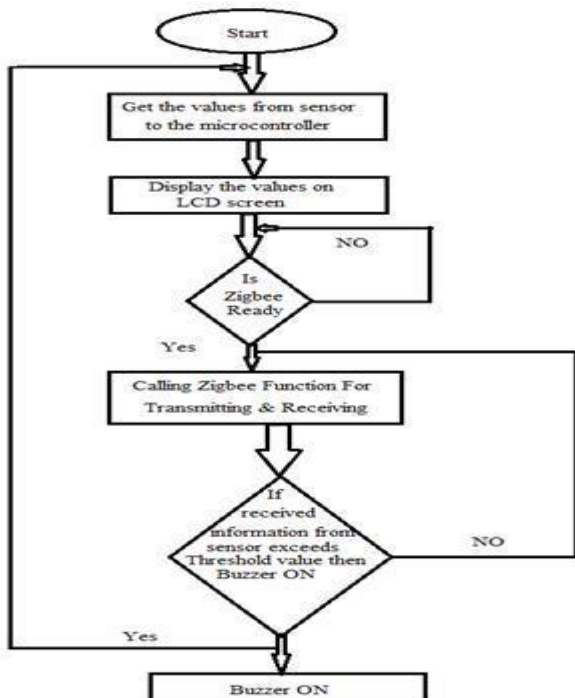

IV. WIRELESS SENSOR NODE ARCHITECTURE

The basic block diagram of a wireless sensor node is presented in figure

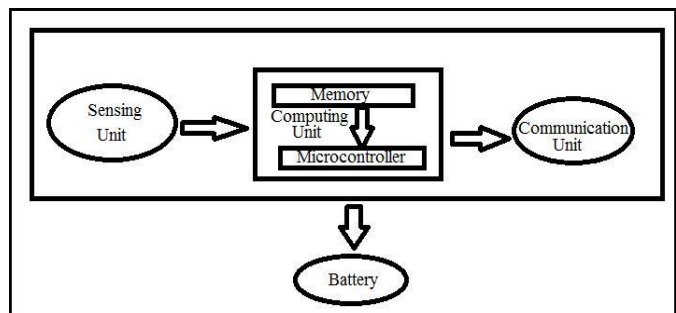

Sensing Unit- It consists of the sensor deployed at the node which collects data at the ground level. This data is the physical raw data which is sampled and converted to the

analog domains and then into the digital form which is then converted into digital forms, which is then sent to the processing unit. Sensing units are usually composed of two subunits: sensors and analog to digital converters. Sensor is a device which is used to translate physical phenomena to electrical signals. Sensors can be classified as either analog or digital devices. There exists a variety of sensors that measure environmental parameters such as temperature, light intensity, sound, magnetic fields, image, etc.

The Processing Unit- The processing unit mainly provides intelligence to the sensor node. The processing unit consists of a microprocessor, which is responsible for control of the sensors, execution of communication protocols and signal processing algorithms on the gathered sensor data.

Transmission Unit- Similar to microcontrollers, transceivers can operate in Transmit, Receive, Idle and Sleep modes. An important observation in the case of most radios is that, operating in Idle mode results in significantly high power consumption, almost equal to the power consumed in the Receive mode. Thus, it is important to completely shut down the radio rather than set it in the idle mode when it is not transmitting or receiving due to the high power consumed. Another influencing factor is that, as the radio's operating mode changes, the transient activity in the radio electronics causes a significant amount of power dissipation. The sleep mode is a very important energy saving feature in WSNs.

Battery - The battery supplies power to the complete sensor node. It plays a vital role in determining sensor node lifetime. The amount of power drawn from a battery should be carefully monitored. Sensor nodes are generally small, light and cheap, the size of the battery is limited. Furthermore, sensors must have a lifetime of months to years, since battery replacement is not an option for networks with thousands of physically embedded nodes. This causes energy consumption to be the most important factor in determining sensor node lifetime.

V. CONCLUSION

In this application, as we are storing the values of the parameters in the PC, the stored values can be used to detect the hazards before they happen. As we are giving the information to the personnel regarding the measures to be taken in case of a hazard, it will be useful for them to save their life before any one comes and help them to come out of the mine.

Reference:

- i. *A Wireless Surveillance and Safety System for Mine Workers based on Zigbee*
- ii. *ZigBee Based Intelligent Helmet for Coal Miners*, Proc. IEEE World Congress on Computer Science And Information Engineering
- iii. *Zigbee based mine safety monitoring system with GSM.*
- iv. *Multi-parameter Monitoring System for Coal Mine based on Wireless Sensor Network Technology*
- v. *Tanmoy Maity, Partha Sarathi Das, Mithu Mukherjee 'A Wireless Surveillance and Safety System for Mine Workers based on Zigbee'.*
- vi. *Coal mining safety Wikipedia(internet)*
- vii. *Indian School Of Mines Internal Links And External data*
- viii. *Safety Conference "Breaking New Ground",*