

Analysis of Power Quality Enhancement in MFGCI with PI and Fuzzy based Active Power Control

SATTI SREE RAMA REDDY

M-tech Student Scholar

Department of Electrical & Electronics Engineering,
Global Institute of Engineering & Technology, Chilukur,
Ranga Reddy (Dt); Telangana, India.
Email: s.sreeramreddy@gmail.com

KHAJA KHADER MOHIUDDIN

Assistant Professor

Department of Electrical & Electronics Engineering,
Global Institute of Engineering & Technology, Chilukur,
Ranga Reddy (Dt); Telangana, India.
Email: khadermohiuddin.khaja@gmail.com

Abstract: Recent scenario in the distribution system is harmonics created by Non-linear load and unbalance current. It affects not only the working of adjacent loads but also shorten the life of power equipment by creating excessive losses. In this paper, a fuzzy controlled shunt active power filter is described to maintain the (Total Harmonic Distortion) THD within the allowable limits defined by IEEE Std. 519-1992 and to reduce reactive power and improve power factor. This Filter draws the opposite harmonics containing current from the load so that source current remain sinusoidal and undistorted. Fuzzy logic controller is used to control the shunt active power filter and the performance of the shunt active filter control strategies has been evaluated in terms of harmonic mitigation. Three-phase reference current waveforms generated by proposed scheme are tracked by the three-phase voltage source converter in a hysteresis band control scheme. A fully functional MATLAB based Simulink model of Shunt Active Power Filter for different types of load (nonlinear, unbalance, both) has been designed based on 'Instantaneous Power Theory' or 'p-q Theory'. The results of simulation comply with all the features described by the theory, justifying employment of Shunt Active Power Filter (SAPF) with fuzzy controller improves power quality compared to conventional Proportional Integral(PI) controller.

1 INTRODUCTION

In recent years Distributed Generation (DG) based on Renewable Energy Sources (RES) has undergone tremendous development globally. Due to the increasing energy demand, reducing fossil fuels and clean energy concepts more and more DG units are connected to the grid at the distribution level [1]. Microgrid which integrates RESs, energy storage devices and local loads are a solution to the present day energy crisis [2]. Power quality is a major issue in a conventional distribution system in the presence of increased usage of nonlinear loads and power electronic based equipments. Poor power quality is a big challenge for the stable, effective and economic operation of an inverter dominated microgrid [1, 3, 4, and 8]. In the near future electricity will be a commodity marketed by judging its quality in a competitive environment [8]. A number of active power filtering techniques have been developed to mitigate the traditional distribution system harmonic issues [6]. The basic structure of an active filter is similar to that of a DG inverter and the primary

function of these grid interfacing inverters is to inject active power to the grid. The DG inverter may not operate at its full capacity at all the time due to the stochastic nature of the renewable energy sources like solar and wind [7]. If controlled properly the unused capacity of DG inverter can be effectively used for providing ancillary services like harmonic, reactive power compensation and unbalance mitigation of the power distribution system [2,]. Such an inverter can be called as a multifunctional grid connected inverter (MFGCI). With the recent developments in microgrid technology power quality enhancement using flexible control of MFGCI is an interesting research topic [10]. Use of MFGCI eliminates the necessity of additional compensating devices and results in a cost effective system [7-9].

Voltage Source inverters are used as the interfacing converters in most of the DG systems. Normally these inverters operate in current controlled mode (CCM) during grid connected operation due to its superior harmonic compensation capability when compared to the voltage controlled mode (VCM). Various control strategies and techniques for enhanced power quality in a grid connected system have been reported recently [8-4]. During harmonic compensation of the nonlinear load current, the fundamental DG current supplied by the interfacing inverter has to be calculated based on the active and reactive power reference.

A control technique with power quality improvement features for the integration of DG systems to the grid is discussed in [12]. In this strategy generation of fundamental DG current component assumes a stiff voltage source at the grid side and does not consider non ideal supply conditions. An open loop power control strategy for optimal power quality compensation in Microgrid using multifunctional grid connected inverters is proposed in [13]. An electrical distribution system is subjected to power fluctuations and uncertainties which causes the voltage at the point of common coupling (PCC) to be unbalanced.

The interaction between the DG inverter nonlinear current and distorted PCC voltages may contribute power control errors in the steady state [14-16]. Hence a closed loop power control strategy is necessary for accurate power tracking in the case of distorted voltages

at the PCC. In [14], a closed loop power control strategy for single phase inverters with active harmonic filtering in stationary frame is proposed for harmonic compensation. The objective of this paper is to develop a control strategy for harmonic current filtering in a three phase grid connected DG system without using extra compensating device. The proposed closed loop control is able to track the active power reference and improve the power quality in the presence of unbalanced and distorted supply voltages. The effectiveness of the control scheme is validated by elaborate simulation studies for different operating modes of the DG inverter under ideal and non-ideal supply conditions.

II SYSTEM DESCRIPTION

A schematic representation of the proposed system is given in Fig 1 R_g and L_g represents the grid resistance and inductance up to the point of common coupling; R_{dg} and L_{dg} represents the equivalent resistance and inductance of the inverter filter, coupling transformer and connecting cables; L_s represents the smoothing inductance inserted in series with the load to reduce the spikes in the grid current due to switching transients; v_a, v_b, v_c represents the voltages at the PCC and i_{la}, i_{lb}, i_{lc} represents the load currents.

III REFERENCE CURRENT GENERATION PRINCIPLE

The control technique employed is based on the analysis of load voltage, load current and inverter currents in the dq synchronous rotating frame. Independent control of active and reactive power can be achieved with more effectiveness in dq frame. The instantaneous angle of the voltage at PCC is obtained by using a phase locked loop (PLL).

a) Calculation of d-axis and q-axis reference currents to supply load active and reactive power:

The active and reactive power injected from the DG link to the grid at the fundamental frequency is

$$P_{dg} = \frac{3}{2}(v_d I_{dgd} + v_q I_{dqq}) \quad (1)$$

$$Q_{dg} = \frac{3}{2}(v_q I_{dgd} - v_d I_{dqq}) \quad (2)$$

Where I_{dgd} and I_{dqq} are the dq- components of DG inverter current at fundamental frequency to manage the active power and reactive power exchange between the grid and RES. v_d and v_q are the PCC voltages in dq frame. The currents at fundamental frequency required to deliver the active and reactive power from the RES has to be supplied by the DG inverter. The corresponding reference currents at fundamental frequency are I_{dgd}^* and I_{dqq}^* , which can be calculated using the open loop and the proposed closed loop power control strategy as explained below,

B) Open Loop Power Control:

In a practical case, the PCC voltages may contain ripple due to the unexpected power fluctuations and excessive use of harmonic polluted loads connected to the system. Hence to generate the fundamental current components, the PCC voltages are filtered in dq frame [13].

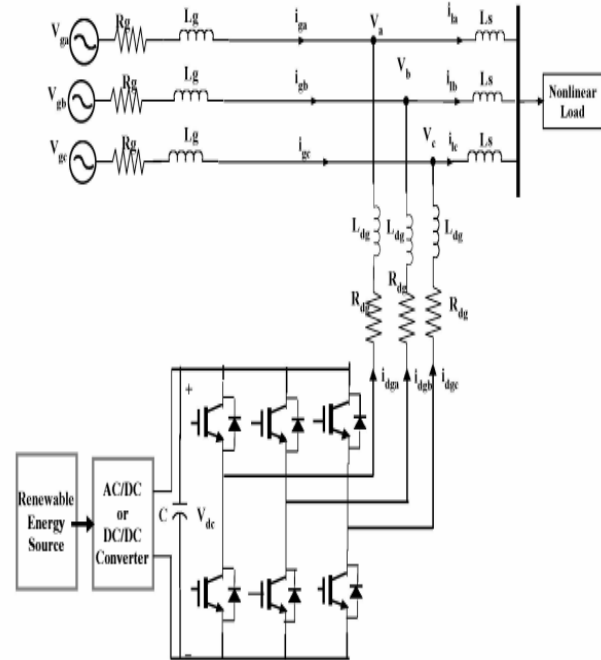

Fig 1 Schematic of the proposed distribution generation system connected to the electrical network

Using equations (1) and (2),

$$\begin{bmatrix} I_{dgd}^* \\ I_{dqq}^* \end{bmatrix} = \frac{1}{\tilde{v}_d^2 + \tilde{v}_q^2} \begin{bmatrix} P^* & Q^* \\ -Q^* & P^* \end{bmatrix} \begin{bmatrix} \tilde{v}_d \\ \tilde{v}_q \end{bmatrix} \frac{2}{3} \quad (3)$$

Where \tilde{v}_d and \tilde{v}_q are the voltages after passing through a low pass filter. P^* and Q^* are the active and reactive power references.

c) Proposed Closed Loop Power Control:

In the proposed closed loop control strategy, the calculated DG active and reactive power are filtered through a low pass filter and compared with the reference powers to get the error signal. The dq - components of inverter reference current at fundamental frequency can be generated by passing the error signal through a PI controller and can be expressed as

$$I_{dgd}^* = (P^* - \tilde{P}_{dg})(k_{p1} + \frac{k_{i1}}{s}) \quad (4)$$

$$I_{dqq}^* = (Q^* - \tilde{Q}_{dg})(k_{p2} + \frac{k_{i2}}{s}) \quad (5)$$

Where P_{dg} and Q_{dg} represent the filtered real and reactive power of the DG inverter, k_{p1}, k_{i1}, k_{p2} and k_{i2} are the proportional and integral gains for minimizing the real and reactive power control errors, As per IEEE 1547 the inverters in a distributed generation system are not permitted to inject reactive power to the grid [5]. As such, the total q-axis reference current for the inverter is

limited to meet only the reactive power demand of the load so that $I_{d,gq}^* = 0$. Hence only active power control is done in both open loop and closed loop control schemes. In rotating synchronous frame the quadrature component of load current i_{lq} is perpendicular to the direct component of voltage ($i_{lq} \perp v_d$). Accordingly the q-axis reference current of the DO inverter can be expressed as

$$i_{d,gq}^* = i_{lq} \quad (6)$$

d) Calculation of Total D-Axis Reference Current:

The d-axis component of the load current can be expressed as

$$i_{ld} = i_{ld1} + \tilde{i}_{ld} \quad (7)$$

Where i_{ld1} is the oscillating component of the load current and i_{ld1} is the fundamental component of load current. In dq frame the fundamental frequency component of the load current appears as a dc component. The harmonic components of the load current can be obtained by using a high pass filter. But due to the excessive phase lag associated with the high pass filter, a second order low pass filter having a cut off frequency of 25 Hz is used to extract the harmonic component of the load current.

i_{ld} Can be expressed as

$$\tilde{i}_{ld} = \sum_{n=2}^{\infty} i_{ldn} \quad (8)$$

$$\sum_{n=2}^{\infty} i_{ldn} = i_{ld}(1 - LPF) \quad (9)$$

The DO inverter has to supply the d-axis component of harmonic load current given by equation (8) and the d-axis component of current at fundamental frequency given by equation (3) or (4) depending upon the type of the power control scheme. Hence the total d-axis reference current for the DO inverter can be expressed as

$$i_{d,gd}^* = \tilde{i}_{ld} + I_{d,gd}^* \quad (10)$$

e) DC Link Voltage Control:

When the power from the RES is equal to zero, the inverter operates in shunt active filter mode. The DO inverter draws an active power component of current for maintaining the dc bus voltage constant and to meet the losses in the inverter. The DC link voltage error can be expressed as

$$v_{dcerr} = v_{dc}^* - v_{dc} \quad (11)$$

The current can be obtained by passing the error through a PI controller and is given by

$$i_{dc} = k_p v_{dcerr} + k_i \int v_{dcerr} dt \quad (12)$$

Where k_p and k_i are the proportional and integral gain constants.

f) Hysteresis Current Control Scheme:

A Hysteresis band current controller is used to generate the switching pulses for the DO inverter. The reference currents generated in dq frame are transformed to natural ABC frame and compared with the inverter currents to generate the error signals.

If $I_{dga}^* - i_{dga} > h_b$, then upper switch is switched ON and lower switch is switched OFF in the inverter leg of phase 'a'.

If $I_{dga}^* - i_{dga} < -h_b$ then upper switch is switched OFF and lower switch is switched ON in the inverter leg of phase 'a'.

Where h_b is the assigned hysteresis band. Using the same principle switching pulses for the other switches in phase 'b' & 'c' are produced. The hysteresis band directly controls the amount of ripples in the current injected into the grid. The main advantages of hysteresis current controller are ease of implementation, extremely good dynamic response, outstanding robustness and independence of load parameter changes [17]. The switching frequency depends on the width of hysteresis band, the size of interfacing inductor L_{dg} to the grid and the DC voltage. As per [18], the relation between switching frequency and the filter inductance can be expressed as

$$L_{dg} = \frac{2V_{dc}}{9h_b f_{sw,max}} \quad (13)$$

Where v_{dc} is the DC link voltage, h_b is the hysteresis band and $f_{sw,max}$ is the maximum switching frequency.

IV INTRODUCTION TO FUZZY LOGIC CONTROLLER

L. A. Zadeh presented the first paper on fuzzy set theory in 1965. Since then, a new language was developed to describe the fuzzy properties of reality, which are very difficult and sometime even impossible to be described using conventional methods. Fuzzy set theory has been widely used in the control area with some application to dc-to-dc converter system. A simple fuzzy logic control is built up by a group of rules based on the human knowledge of system behavior. Matlab/Simulink simulation model is built to study the dynamic behavior of dc-to-dc converter and performance of proposed controllers. Furthermore, design of fuzzy logic controller can provide desirable both small signal and large signal dynamic performance at same time, which is not possible with linear control technique. Thus, fuzzy logic controller has been potential ability to improve the robustness of dc-to-dc converters. The basic scheme of a fuzzy logic controller is shown in Fig 5 and consists of four principal components such as: a fuzzification interface, which converts input data into suitable linguistic values; a

knowledge base, which consists of a data base with the necessary linguistic definitions and the control rule set; a decision-making logic which, simulating a human decision process, infer the fuzzy control action from the knowledge of the control rules and linguistic variable definitions; a de-fuzzification interface which yields non fuzzy control action from an inferred fuzzy control action [10].

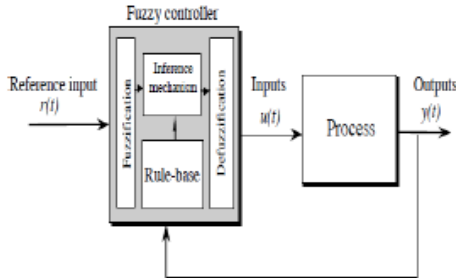

Fig.2. General Structure of the fuzzy logic controller on closed-loop system

The fuzzy control systems are based on expert knowledge that converts the human linguistic concepts into an automatic control strategy without any complicated mathematical model [10]. Simulation is performed in buck converter to verify the proposed fuzzy logic controllers.

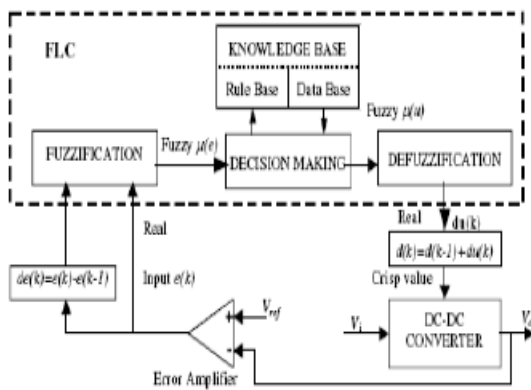

Fig.3. Block diagram of the Fuzzy Logic Controller (FLC) for dc-dc converters

A. Fuzzy Logic Membership Functions:

The dc-dc converter is a nonlinear function of the duty cycle because of the small signal model and its control method was applied to the control of boost converters. Fuzzy controllers do not require an exact mathematical model. Instead, they are designed based on general knowledge of the plant. Fuzzy controllers are designed to adapt to varying operating points. Fuzzy Logic Controller is designed to control the output of boost dc-dc converter using Mamdani style fuzzy inference system. Two input variables, error (e) and change of

error (de) are used in this fuzzy logic system. The single output variable (u) is duty cycle of PWM output.

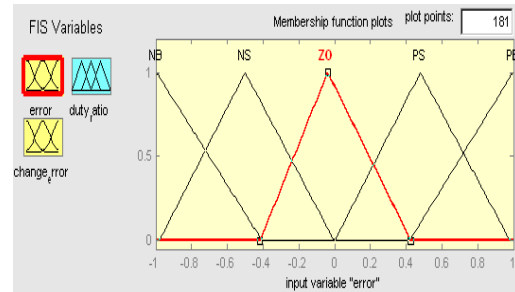

Fig. 4. The Membership Function plots of error

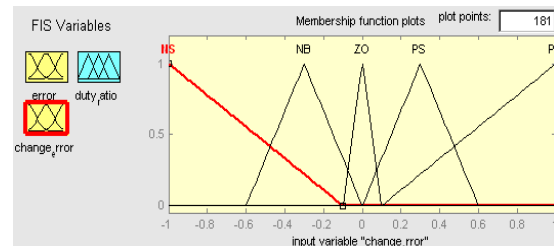
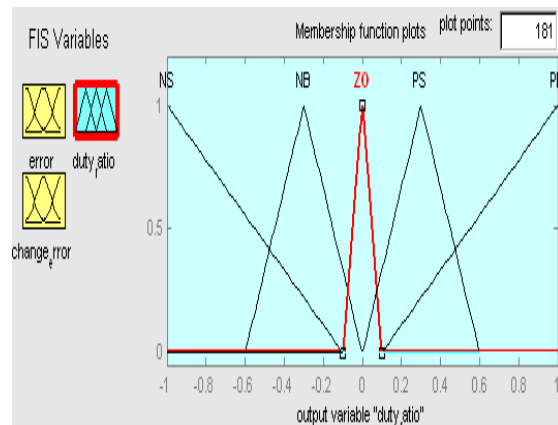

Fig.5. The Membership Function plots of change error



The Membership Function plots of duty ratio

B. Fuzzy Logic Rules:

The objective of this dissertation is to control the output voltage of the boost converter. The error and change of error of the output voltage will be the inputs of fuzzy logic controller. These 2 inputs are divided into five groups; NB: Negative Big, NS: Negative Small, ZO: Zero Area, PS: Positive small and PB: Positive Big and its parameter [10]. These fuzzy control rules for error and change of error can be referred in the table that is shown in Table II as per below:

Table II
Table rules for error and change of error

(de) \ (e)	NB	NS	ZO	PS	PB
NB	NB	NB	NB	NS	ZO
NS	NB	NB	NS	ZO	PS
ZO	NB	NS	ZO	PS	PB
PS	NS	ZO	PS	PB	PB
PB	ZO	PS	PB	PB	PB

V MATLAB/SIMULINK RESULTS

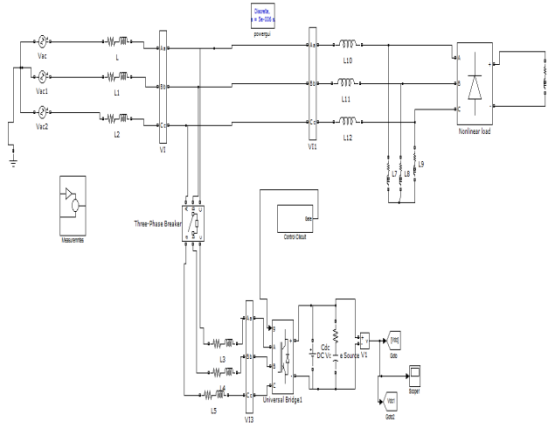

Fig 6 Simulation model for generation of switching pulses for the DG inverter

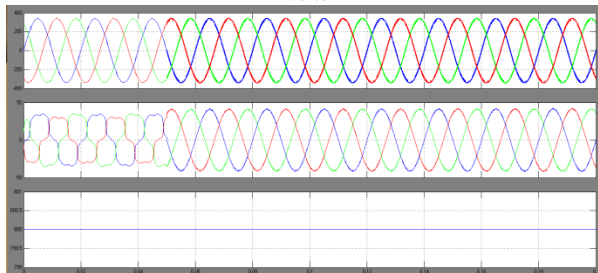

Fig 7 Simulation waveform for Grid voltage, Grid currents and DC link voltage during shunt active filter mode of the DG inverter

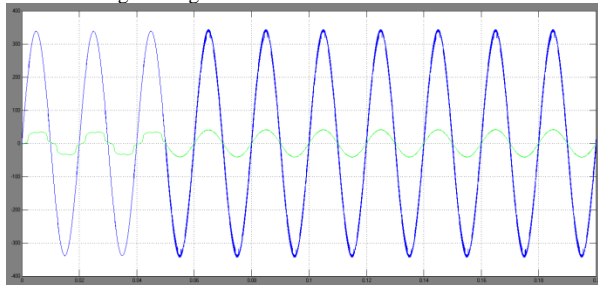

Fig 8 Simulation waveform for source voltage, source currents

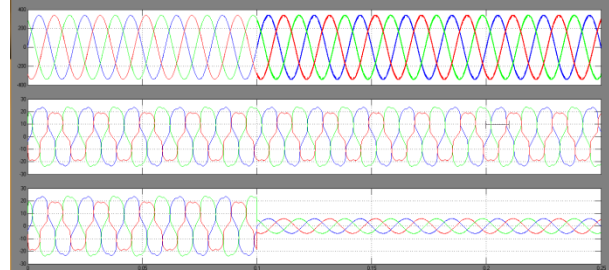

Fig 9 Simulation waveform for Grid voltage, Grid current and DG current in phase a under forward power flow mode

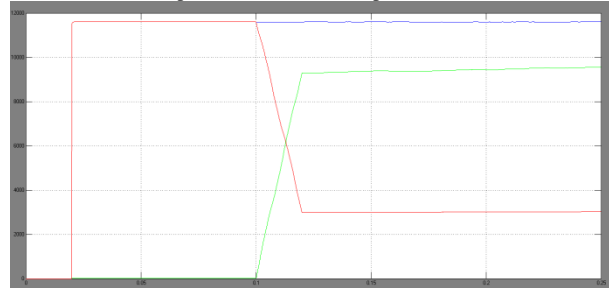

Fig 10 Simulation waveform for forward reactive power

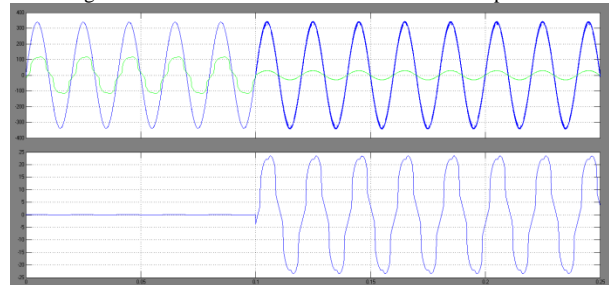

Fig 11 Simulation waveform for Grid voltage, Grid current and DG current in phase a under forward mode

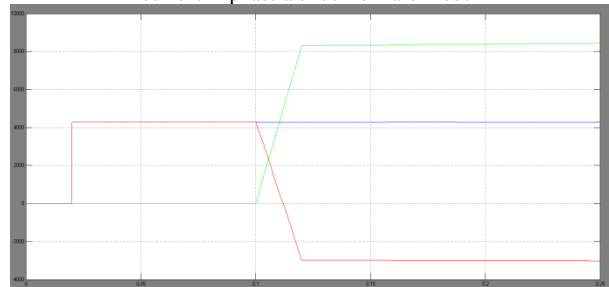

Fig 12 Simulation waveform for reverse reactive power

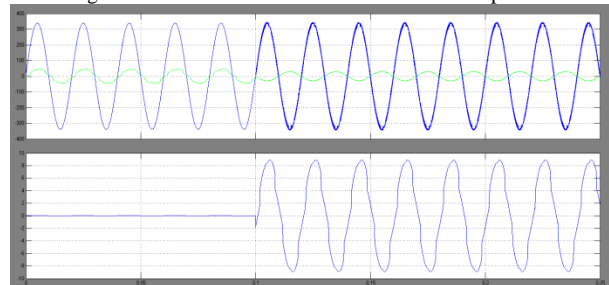

Fig 13 Simulation waveform for Grid voltage, Grid current and DG current in phase a under reverse mode

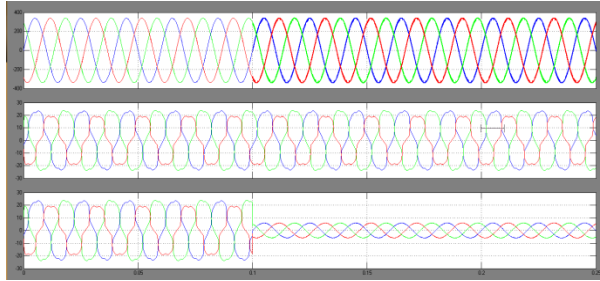

Fig 14 Simulation waveform for Grid voltage, Grid current and DG current in phase under reverse power flow mode

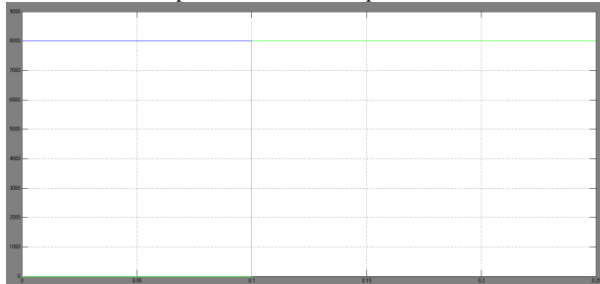

Fig 15 Simulation waveform for DG Real power under non ideal supply conditions using open loop and closed loop control

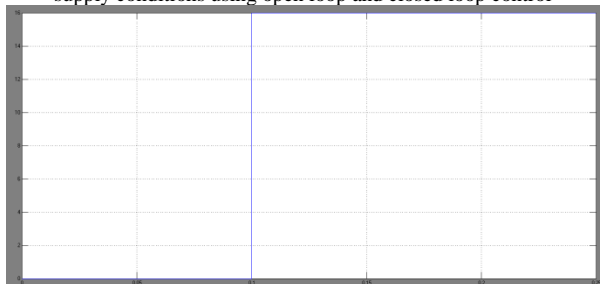

Fig 16 Simulation waveform for Fundamental current tracking in Closed loop control

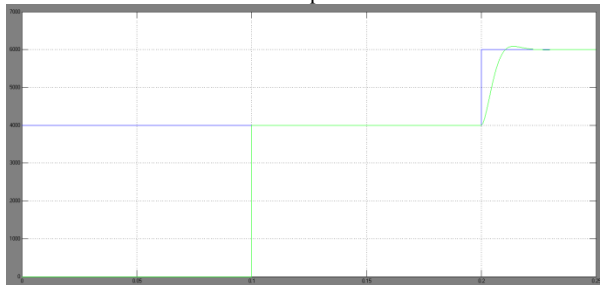

Fig 17 Simulation waveform for Dynamic performance of the proposed closed loop power control

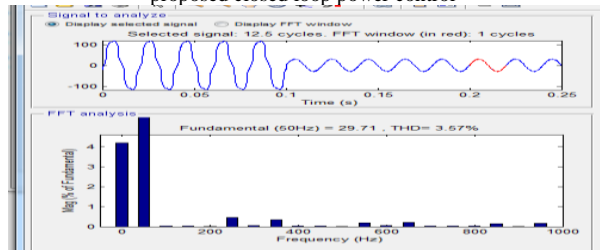

Fig 18 source current THD with PI controller 3.57%

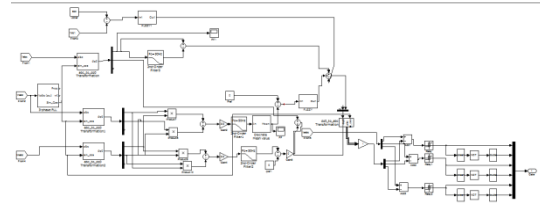

Fig 19 Fuzzy logic control block diagram for generation of switching pulses for the DG inverter

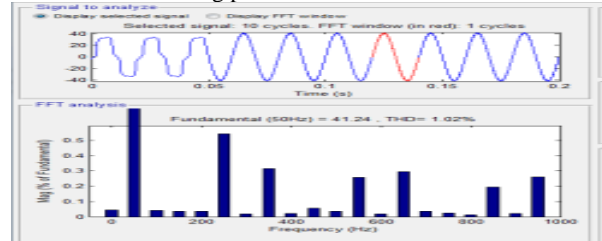

Fig 20 source current THD is 1.02 with fuzzy logic controller

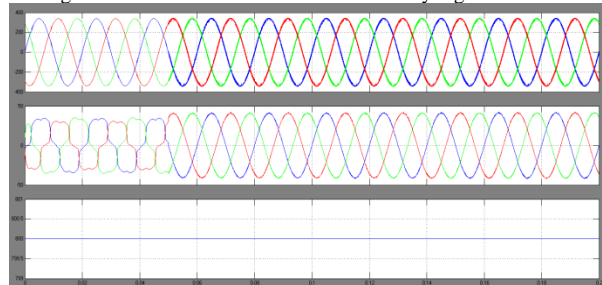

Fig 21 simulation wave form of Grid voltage, Grid current and DC voltage with Fuzzy logic controller

V CONCLUSION

This paper discusses the capabilities of a MFGCI for enhancing the power quality in a grid connected distributed generation system. It has been shown that the DG inverter can be effectively utilized to inject real power from the RES in the forward and reverse power flow modes and/or operate as a shunt active power filter. The proposed closed loop active power control strategy achieves accurate power tracking with zero steady state errors under ideal and non-ideal supply conditions and can be used as a control technique for integration of DG inverters to the utility grid. The method laminates the need of extra power conditioning devices to improve the power quality. The effectiveness of the control scheme is verified under balanced and unbalanced nonlinear load conditions. With the proposed method the combination of nonlinear loads and the DG inverter is seen as a resistive load at the PCC and the grid currents re maintained sinusoidal. To proposed with fuzzy logic controller to reduce the THD and improve the power quality and maintain the grid currents re maintained sinusoidal

REFERENCES

- [1] F. Blaabjerg, R. Teodorescu, M. Liserre, and Adrian V.Timbus," Overview of Control and Grid Synchronization for Distributed power Generation

- Systems," IEEE Trans. Ind. Electron., vol.53,no.5, pp.1398-1409, Oct. 2006
- [2] J. Rocabert, A. Luna, F. Blaabjerg and P.Rodrigues, Control of Power Converters in AC Microgrids," IEEE Trans. Power Electron., vol. 27, no.11, pp.4734-4748, Nov. 2012
- [3] I.El-Samahy and E.El-Saadany, "The effect of DG on Power Quality in a deregulated environment," in Proc. IEEE PESGM. 2005, pp. 2969-2976
- [4] F. Blaabjerg, Z. Chen, and S. Kjaer, "Power Electronics efficient interface in dispersed power generation systems," IEEE Trans. Power Electron., vol. 19, no. 5, pp. 1184-1194, Sep. 2004.
- [5] IEEE Standard for Interconnecting Distributed Resources with Electric Power Systems, IEEE Std. 1547, 2003.
- [6] S.Rahmani, N. Mendalek, K. Al-Haddad, "Experimental design of a nonlinear control technique for three phase shunt active power filter," IEEE trans. Ind. Electron, vol.57,no.10,oct 2010.
- [7] N. Pogaku and T.C.Green, "Harmonic mitigation throughout a distribution system- A distributed generator based solution," IEE Proc. Gener. Transm. Distrib, vol. 153, No.3, pp. 350-58, May 2006.
- [8] Z. Zeng, H. Yang, R. Zhao and C. Cheng, " Topologies and control strategies of multifunctional grid connected inverters for power quality enhancement: A comprehensive review, Renewable and Sustainable Energy Reviews, 24, pp 223-270, 2013.
- [9] C. I. Gajanayake, D. M. Vilathgamuwa, P. c. Loh, R. Teodorescu and F. Blaabjerg, " Z-Source -Inverter-based flexible distributed generation system solution for grid power quality improvement," IEEE Trans. Energy Conv, vol. 24, no.3, pp.695-704, Sept. 2009.
- [10] J. He, Y. W. Li, F. Blaabjerg, " Flexible microgrid power quality enhancement using adaptive hybrid voltage and current controller." IEEE trans. Ind. Electron.. 61. no.6. June 2014.
- [11] M. Singh, S. Member, V. Khadkikar, A. Chandra, and S. Member, "Grid Interconnection of renewable energy sources at the distribution level with power-quality improvement features," IEEE Trans. Power Delivery vol. 26, no. 1, pp. 307-315, 2011.
- [12] E. Pouresmaeil, C. M - Espinar, M. M - Campos, D. M- Miracle and O. G -Bellmunt, "A Control technique for integration of DG units to the Electrical networks," IEEE Trans. Power Electron., vol. 60, no. 7, pp. 2881-2893, July 2013.
- [13] Z. Zeng, H Yang, Q Tang, R Zhao, " Objective-oriented power quality compensation of multifunctional grid -tied inverters and its application in Microgrids," IEEE Trans. Power Electron., vol.30, no.3, pp. 1255-1265, March 2015.
- [14] J. He, Y. Wei Li, F. Blaabjerg, X. Wang, "Active harmonic filtering using current-controlled grid - connected DG units with closed loop power control," IEEE Trans. Power Electron., vol. 29, no. 2, pp. 642-653, Feb. 2014.
- [15] H. Akagi, E. H. Watanabe, and M. Aredes, Instantaneous Power Theory and Applications to Power Conditioning, Hoboken, NJ: Wiley-IEEE Press, Feb. 2007.
- [16] R. Teodorescu, M. Liserre, and P. Rodriguez, Grid Converters for Photovoltaic and Wind Power Systems, IEEE Wiley, 2011.