



Power Factor Correction of BL-CSC Converter with fuzzy logic controller Fed BLDC Motor Drive

RAVINUTHALA SRINIVAS

M-tech Student Scholar
Department of Electrical &
Electronics Engineering,
Sri Chundi Ranganayakulu
Engineering College,
Ganapavaram, Guntur (Dt); A.P,
India.

BONIGALA SUBHASHINI

Assistant Professor
Department of Electrical &
Electronics Engineering,
Sri Chundi Ranganayakulu
Engineering College,
Ganapavaram, Guntur (Dt); A.P,
India.

N. HANUMA NAIK

Head of the Department
Department of Electrical &
Electronics Engineering,
Sri Chundi Ranganayakulu
Engineering College,
Ganapavaram;
Guntur (Dt); A.P, India.

Abstract- The proposed BL-CSC converter operating in a discontinuous inductor current mode is used to achieve a unity power factor at the AC mains using a single voltage sensor. The speed of BLDC motor is controlled by varying the DC bus voltage of the voltage source inverter (VSI) feeding BLDC motor via a PFC converter. Therefore, the BLDC motor is electronically commutated such that the VSI operates in fundamental frequency switching for reduced switching losses. Moreover, the bridgeless configuration of CSC converter offers low conduction losses due to partial elimination of diode bridge rectifier at the front end. The switching losses in the VSI have been reduced by the use of fundamental frequency switching by electronically commutating the BLDC motor. Moreover the use of front end CSC improves the power factor at AC mains. a design methodology is introduced that blends the classical PI and the fuzzy controllers in an intelligent way and thus a new intelligent controller has been achieved. Basically, in this design methodology, the classical PID and fuzzy controller have been combined by a blending mechanism that depends on a certain function of actuating error. Moreover, an intelligent switching scheme is induced on the blending mechanism that makes a decision upon the priority of the two controller parts; namely, the classical PID and the fuzzy constituents. The simulations done on various processes using the new fuzzy is PID controller provides 'better' system responses in terms of transient and steady-state performances when compared to the pure classical PID or the pure fuzzy controller applications. The performance graph has been plotted for the total harmonic distortion (THD) and the power factor (PF). A front end Canonical switching cell converter operating in Discontinuous Inductor Current Mode (DICM) is proposed for PFC operation at AC mains. Fuzzy logic is introduced in order to suppress the chattering and enhancing the robustness of the PFC control system. The performance has been evaluated using Matlab-Simulink.

Index Terms—Bridgeless canonical switching cell (BL-CSC) converter, brushless dc (BLDC) motor, discontinuous inductor current mode (DICM), power factor correction (PFC), power quality, fuzzy logic controller.

1. INTRODUCTION

A Brushless DC motor drives have gained importance in the last decade due to power quality improvements that have also resulted in exceptional performance compared with other conventional drives. The advantages of including high torque to weight ratio, more torque per

watt (increased efficiency), increased reliability, reduced noise, longer lifetime, elimination of ionizing sparks from the commutator, and overall reduction of electromagnetic interference (EMI). The applications of BLDC motor are many low and medium power applications ranging from household appliance, medical equipment, heating, ventilation and air conditioning. Two key performance parameters of brushless DC motors are the motor constants K_v and K_m . Environments and requirements in which manufacturers use brushless type DC motors include maintenance free operation, high speeds, and operation where sparking is hazardous or could affect electronically sensitive equipment. However there are three main problems are considered in BLDC motor: they are 1) providing fast speed response, 2) improving the power factor near to unity in ac mains and 3) the reduction of torque repulsion [1-4].

The switching losses are reduced by using a concept of variable dc link voltage for speed control of BLDC motor [5]. Recently, fuzzy inference system (FIS) is widely used because of its good performance, in cases when the system or process is complicated and classical method cannot work well. Additionally, fuzzy system formulates human knowledge in systematic manner and puts them into engineering systems. But there is a problem associated with FIS, which is the time consuming process to tune the parameters of FIS relying on human knowledge by trial and error. So, there has been recently a surge of interest to combine neural network and FIS because of its both advantages of fuzzy inference systems and artificial neural networks [6].

The selection of the membership functions and the development of fuzzy control rules is difficult task without the information from the skilled operator. More over the fuzzy control rules could not be defined properly if the skilled operator is unable to give the exact instructions about the process operation. The artificial neural networks have the learning capability which gains the knowledge of a process automatically from the sample input and output relationship of the process [7-9]. In conventional Power factor correction based CSC converter has a combination of a switch(S), a capacitor (C), and a diode (D) is called as CSC converter. With proper design and selection of parameters, this

combination is used to achieve PFC operation when fed by a single phase supply via a DBR and a DC filter.

In the conventional scheme the BLDC motor drive system is fed by a diode bridge rectifier (DBR) which draws a current from ac mains with higher harmonic levels, also the power factor has been affected and it is not satisfies the PQ standard IEC 61000-3-2, so the power factor correction (PFC) is required for attaining good PQ parameter. The boost converter is widely used in the BLDC motor drives, in which the DC link voltage is maintained constant and the speed is controlled by controlling the PWM pulses of the VSI. This system has a drawback for the higher amount of the switching losses in the VSI switches due to higher level of the switching frequency at the inverter switches and the higher current levels [10].

At present, conventional PID-type controllers are most widely used in control of industrial stoker-red boilers due to their simple control structure ease of design and inexpensive cost. However, these PID controllers cannot yield a good control performance due to high nonlinearity and uncertainty of the boiler systems. Furthermore, when there exists a strong load change or a large disturbance, the PID-type controller might be out of control so that a manual control must be operational. It was "rst reported about 20 years ago that a fuzzy logic controller is very suitable for a controlled object with nonlinearity and even with unknown structure. One of the widely used design methods for fuzzy controllers is to de"ne membership functions of linguistic variables and to formulate fuzzy rules by control engineers. Since solid fuels-coal causes a large time lag, it is laborious to "nd manually fuzzy rules and membership functions during system operation. Another approach for design of the fuzzy controller is to adapt rule base or/and membership functions by self-organizing algorithms or neural network according to previous responses until a desired control performance is achieved. However, this adaptive strategy might not be used for combustion control of a stoker-red boiler due to its convergent problem [11].

II. BLDC MOTOR

Brushless DC (BLDC) motor drives have gained importance in the last decade due to power quality improvements that have also resulted in exceptional performance compared to other conventional drives. The advantages of high efficiency, high reliability, high ruggedness, low EMI problems and excellent performance over a wide range of speed control have made this motor popular in the industry. The BLDC motor is suited to many low and medium power applications ranging from household appliances, medical equipments, position actuators, heating, ventilation and air conditioning (HVAC), motion control and

transportation. BLDC motors are synchronous motors having permanent magnets on the rotor, and three phase windings on the stator. An electronic commutation based on the rotor position sensed by Hall Effect sensors is used which eliminates the problems associated with conventional DC motors such as sparking, noise, electromagnetic interference (EMI) and maintenance problems. Therefore, power factor correction (PFC) converters are used for improving the power quality at the AC mains. These converters have less number of components and thus have low losses associated with them.

A. Principle

BLDC motors are basically inside-out DC motors. In a DC motor the stator is a permanent magnet. The rotor has the windings, which are excited with a current. The current in the rotor is reversed to create a rotating or moving electric field by means of a split commutator and brushes. On the other hand, in a BLDC motor the windings are on the stator and the rotor is a permanent magnet. Hence the term inside-out DC motor. Many motor types can be considered brushless; including stepper and AC-induction motors, but the term brushless is given to a group of motors that act similarly to DC brush type motors without the limitations of a physical commutator. To build a brushless motor, the current-carrying coils must be taken off the rotating mechanism. In their place, the permanent magnet will be allowed to rotate within the case. The current still needs to be switched based on rotary position; here, shows a reversing switch is activated by a cam. This orientation follows the same basic principle of rotary motors; the torque produced by the rotor varies trapezoidal with respect to the angle of the field. As the angle θ increases, the torque drops to an unusable level. Fig.1 shows the basic operation of BLDC Motor. Fig.2 shows the current and torque of BLDC Motor.

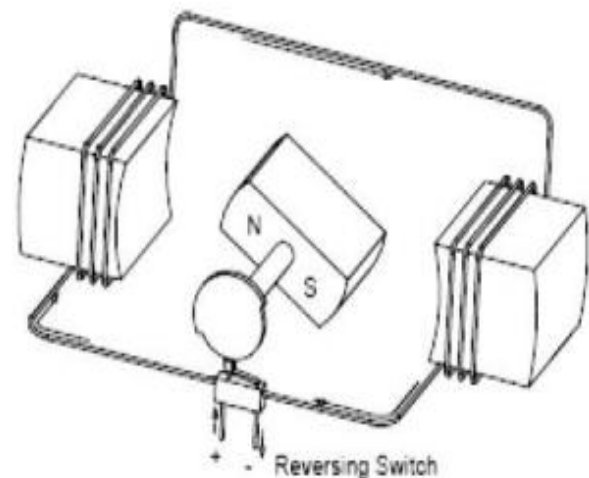

Fig.1 Basic operation of BLDC Motor.

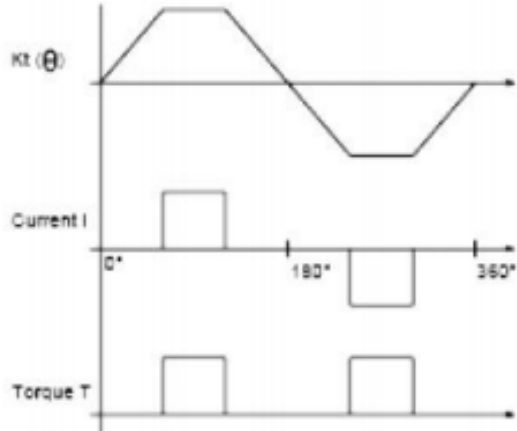

Fig.2 Waveform of current and torque.

III. PFC BL-CSC CONVERTER-FED BLDC MOTOR DRIVE

Fig. 3 shows the proposed BL-CSC-converter-based VSI fed BLDC motor drive. As shown in this figure, the DBR is eliminated in this BL-CSC converter, thereby reducing the conduction losses associated with it. This BL-CSC converter is designed to operate in a discontinuous inductor current mode (DICM) such that the currents flowing through inductors L_{i1} and L_{i2} are discontinuous, whereas the voltage across the intermediate capacitors C_1 and C_2 remains continuous in a switching period. An approach of variable dc link voltage for controlling the speed of the BLDC motor is used, and it is electronically commutated for reduced switching losses in the VSI. The operation, design, and control of this BL-CSC converter fed BLDC motor drive are explained in the following sections. Performance of the proposed drive is verified with test results obtained on a developed prototype with improved power quality at the ac mains for a wide range of speeds and supply voltages. A brief comparison of the proposed configuration with the existing bridgeless converter configurations is tabulated. It shows the total number of components (Switch—Sw, Diode D, Inductor—L, and Capacitor—C) and the components conducting during each half-cycle of supply voltage. The bridgeless buck [3] and boost converter [4], [5] configurations are not suitable for the required application due to requirement of high voltage conversion ratio (i.e., voltage bucking and boosting) for controlling the speed over a wide range. As compared with the various bridgeless configurations of Cuk [6]–[8], SEPIC [9], [10], and Zeta converters [11], the proposed BL-CSC converter has the relatively lower number of components and least number of conducting devices during each half-cycle of the supply voltage, whereas the proposed configuration exhibits the minimum conduction losses due to the conduction of minimum number of components during each half line cycle.

IV. OPERATING PRINCIPLE OF THE PFC BL-CSC CONVERTER

The operation of the BL-CSC converter is classified into two major categories.

A. Operation in Positive and Negative

Half-Cycles of Supply this bridgeless converter is designed such that two switches operate for positive and negative half-cycles of the supply voltage. Fig. 3(a)–(f) shows the operation of the proposed BL-CSC converter for positive and negative half-cycles of the supply voltage, respectively. As shown in Fig. 4(a)–(c), during the positive half-cycle of the supply voltage, the input side current flows through switch Sw_1 , inductor L_{i1} , and a fast recovery diode D_p . Similarly, switch Sw_2 , inductor L_{i2} , and diode D_n conduct for a negative half-cycle of the supply voltage, as shown in Fig. 4(d)–(f). Fig. 4(a) shows waveforms of supply voltage with inductor currents (i_{L1} and i_{L2}) and intermediate capacitor voltages (V_{C1} and V_{C2}). The proposed converter is operating in DICM, i.e., the inductor currents (i_{L1} and i_{L2}) are discontinuous, and the voltages across the intermediate capacitor (V_{C1} and V_{C2}) remain continuous with a permissible amount of voltage ripple in a complete switching period.

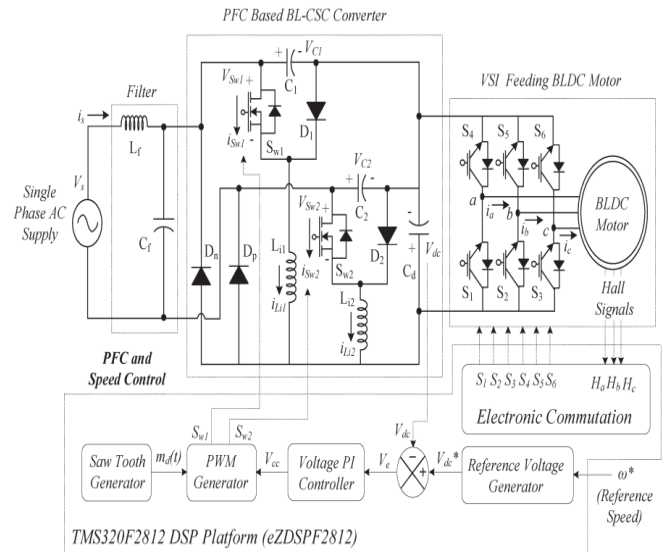

Fig.3. Proposed BL-CSC converter-fed BLDC motor drive.

B. Operation during Complete Switching Period

The proposed BL-CSC converter is designed to operate in DICM such that current in inductors L_{i1} and L_{i2} becomes discontinuous for a switching period. Fig. 4(a)–(f) shows different modes of operation during a complete switching period for positive and negative half-cycles of the supply voltage, respectively. Fig. 4(b) shows the associated waveforms during the three modes of operations.

Mode I-A: As shown in Fig. 4(a), when switch Sw_1 is turned on, the input side inductor L_{i1} starts charging via diode D_p , and current i_{L1} increases, whereas the intermediate capacitor C_1 starts discharging via switch Sw_1 to charge the dc link capacitor C_d . Therefore, the

voltage across intermediate capacitor VC1 decreases, whereas the dc link voltage Vdc increases.

Mode I-B: When switch Sw1 is turned off, the energy stored in inductor Li1 discharges to dc link capacitor Cd via diode D1, as shown in Fig. 3(b). The current iLi reduces, whereas the dc link voltage continues to increase in this mode of operation.

Intermediate capacitor C1 starts charging, and voltage VC1 increases, as shown in Fig. 4(b).

Mode I-C: This mode is the DCM of operation as the current in input inductor Li1 becomes zero, as shown in Fig. 4(c). The intermediate capacitor C1 continues to hold energy and retains its charge, whereas the dc link capacitor Cd supplies the required energy to the load. The similar behavior of the converter is realized for the other negative half-cycle of the supply voltage. An inductor Li2, an intermediate capacitor C2, and diodes Dn and D2 conduct in a similar way, as shown in Fig. 4(d)–(f).

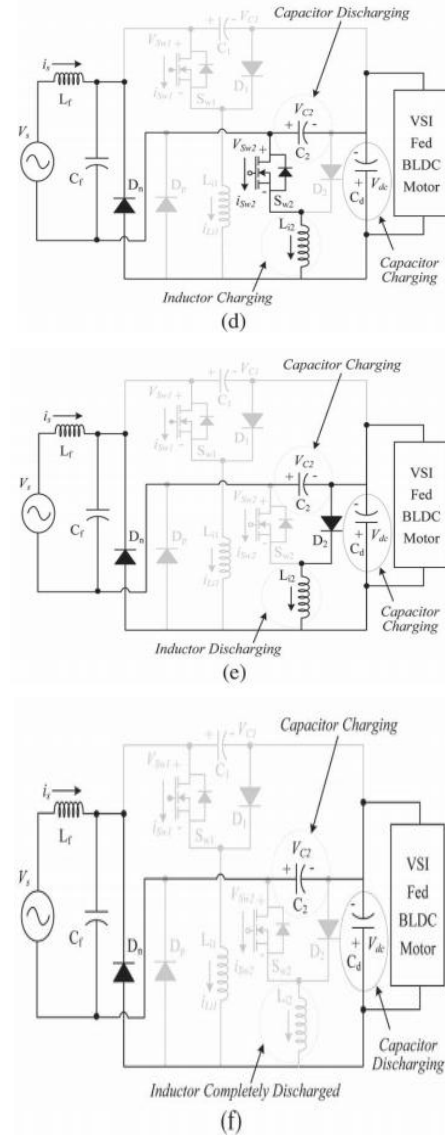
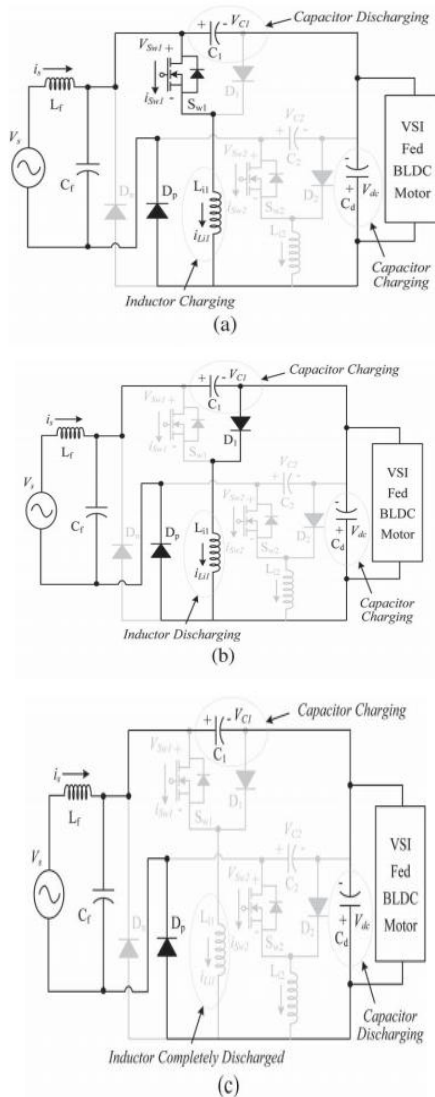

Fig. 4. Different modes of operation of the proposed BL-CSC converter. (a) Mode I-A. (b) Mode I-B. (c) Mode I-C. (d) Mode II-A. (e) Mode II-B. (f) Mode II-C.

V. CONTROL OF THE PFC BL-CSC CONVERTER-FED BLDC MOTOR DRIVE

The control of the proposed PFC based BL-CSC converterfed BLDC motor drive is divided into two parts. This includes the control of the PFC converter for dc link voltage control and the electronic commutation of BLDC motor.

A. Control of the Front-End PFC Converter

A voltage follower approach is used for the control of the BL-CSC converter operating in DICM. A single voltage sensor is required for controlling the dc link voltage for speed control of BLDC motor, and inherent PFC is achieved at the ac mains [2]. Fig. 5 shows a complete block diagram for the control of dc link voltage.

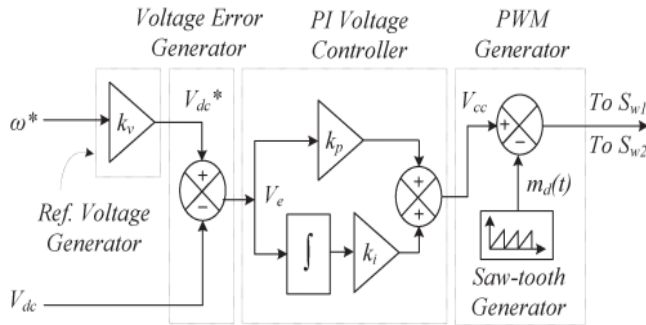

Fig. 5. PI Control of the PFC BL-CSC converter feeding BLDC motor drive.

This control scheme consists of a ‘reference voltage generator,’ a ‘voltage error generator,’ a voltage controller, and a PWM generator. A reference voltage generator generates a reference voltage V_{dc}^* by multiplying the reference speed ω^* with the motor’s voltage constant k_v as

$$V_{dc}^* = k_v \omega^*$$

The voltage error generator compares this reference dc link voltage (V_{dc}^*) with the sensed dc link voltage (V_{dc}) to generate an error voltage (V_e), which is given as

$$V_e(k) = V_{dc}(k)^* - V_{dc}(k)$$

Where ‘k’ represents the kth sampling instance.

This error voltage V_e is given to a voltage proportional–integral (PI) controller to generate a controlled output voltage V_{cc} , which is expressed as

$$V_{cc}(k) = V_{cc}(k-1) + K_p \{V_e(k) - V_e(k-1)\} + K_i V_e(k)$$

Where K_p and K_i are the proportional and integral gains of the PI controller, respectively.

Finally, the PWM signals are generated by comparing the output of PI controller (V_{cc}) with the high-frequency saw tooth

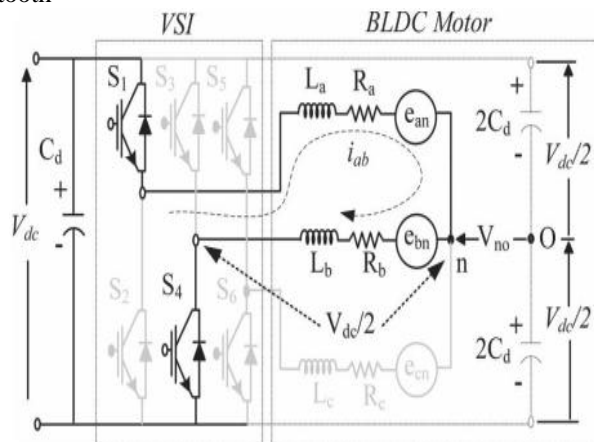

Fig. 6. Three-phase VSI feeding a BLDC motor.

TABLE I

Switching States for Electronic Commutation of BLDC Motor Based On Hall-Effect Position Signals

$\theta(^\circ)$	Hall Signals			Switching States					
	H_a	H_b	H_c	S_1	S_2	S_3	S_4	S_5	S_6
NA	0	0	0	0	0	0	0	0	0
0-60	0	0	1	1	0	0	0	0	1
60-120	0	1	0	0	1	1	0	0	0
120-180	0	1	1	0	0	1	0	0	1
180-240	1	0	0	0	0	0	1	1	0
240-300	1	0	1	1	0	0	1	0	0
300-360	1	1	0	0	1	0	0	1	0
NA	1	1	1	0	0	0	0	0	0

signal (m_d), which are given as

$$\text{for } V_S > 0; \begin{cases} \text{if } m_d < V_{cc} \text{ then } S_{w1} = \text{‘ON’} \\ \text{if } m_d \geq V_{cc} \text{ then } S_{w1} = \text{‘OFF’} \end{cases}$$

$$\text{for } V_S < 0; \begin{cases} \text{if } m_d < V_{cc} \text{ then } S_{w2} = \text{‘ON’} \\ \text{if } m_d \geq V_{cc} \text{ then } S_{w2} = \text{‘OFF’} \end{cases}$$

Where S_{w1} and S_{w2} represent the gate signals to PFC switches S_{w1} and S_{w2} , respectively. The modeling and stability analysis of the proposed converter is given in Appendix B.

B. Control of BLDC Motor

Hall-effect position sensors are used to sense the rotor position to achieve electronic commutation of BLDC motor. A standard commutation technique is used for this trapezoidal back electromotive force (EMF) BLDC motor, where only two stator phases conduct at any given instant of time. With the help of rotor position information, the switches in the VSI are switched ON and OFF to ensure proper direction of flow of current in respective windings. Hall-effect position sensors (H_a , H_b , and H_c) are used for sensing the rotor position on a span of 60° for electronic commutation. The conduction states of two switches (S_1 and S_4) are shown in Fig. 6. A line current i_{ab} is drawn from the dc link, whose magnitude depends on the applied dc link voltage V_{dc} , back EMFs (e_{an} and e_{bn}), resistances (R_a and R_b), and mutual and self-inductances (M and L_a and L_b) of the stator windings. Table I shows the different switching states of the VSI feeding a BLDC motor based on the Hall-effect position signals (H_a – H_c).

VI. FUZZY LOGIC CONTROL

L. A. Zadeh presented the first paper on fuzzy set theory in 1965. Since then, a new language was developed to describe the fuzzy properties of reality, which are very difficult and sometime even impossible to be described using conventional methods. Fuzzy set theory has been widely used in the control area with some application to power system [5]. A simple fuzzy logic control is built up by a group of rules based on the human knowledge of system behavior. Matlab/Simulink simulation model is built to study the dynamic behavior of converter. Furthermore, design of fuzzy logic controller can provide desirable both small signal and large signal dynamic performance at same time, which is not possible with linear control technique. Thus, fuzzy logic controller has

been potential ability to improve the robustness of compensator.

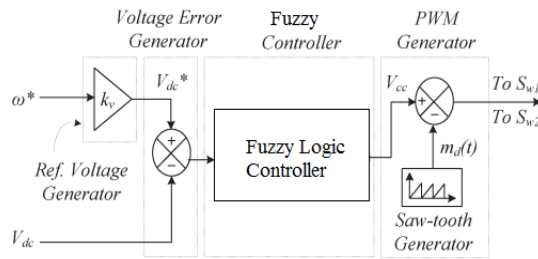

Fig. 7. Fuzzy logicControl of the PFC BL-CSC converter feeding BLDC Motor Drive.

The basic scheme of a fuzzy logic controller is shown in Fig 8 and consists of four principal components such as: a fuzzy fication interface, which converts input data into suitable linguistic values; a knowledge base, which consists of a data base with the necessary linguistic definitions and the control rule set; a decision-making logic which, simulating a human decision process, infer the fuzzy control action from the knowledge of the control rules and linguistic variable definitions; a de-fuzzification interface which yields non fuzzy control action from an inferred fuzzy control action [10].

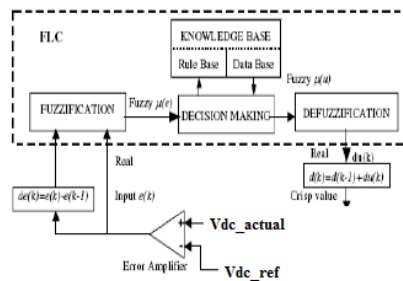

Fig.8.Block diagram of the Fuzzy Logic Controller (FLC) for proposed converter.

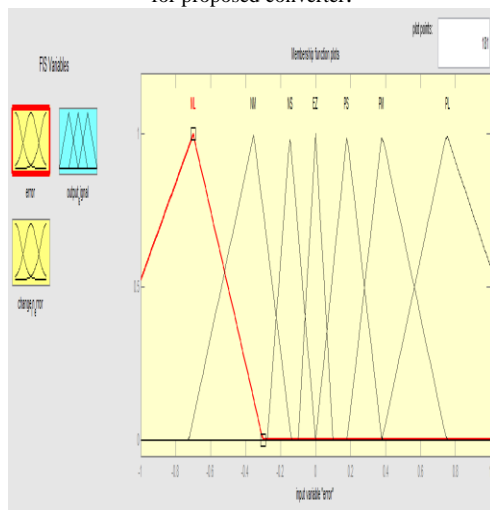

Fig.9. Membership functions for error.

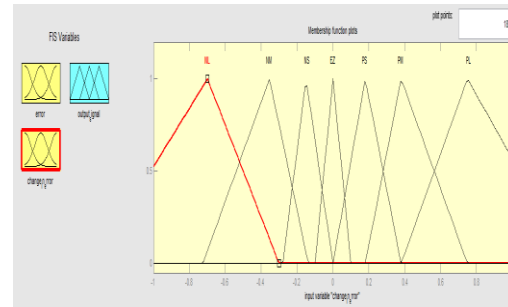

Fig.10. Membership functions for change_in_error.

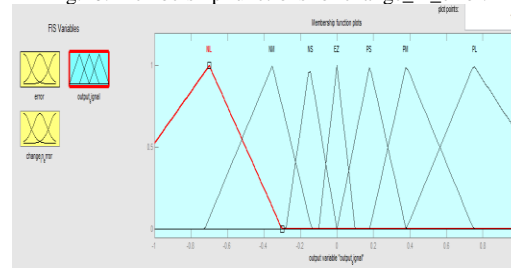

Fig.11. Membership functions for Output.

Table II

Table rules for error and change of error.

Error \ Change error	NL	NM	NS	EZ	PS	PM	PL
NL	NL	NL	NL	NL	NM	NS	NL
NM	NL	NL	NL	NM	NS	EZ	NM
NS	NL	NL	NM	NS	EZ	PS	NS
EZ	NL	NM	NS	EZ	PS	PM	EZ
PS	NM	NS	EZ	PS	PM	PL	PS
PM	NS	EZ	PS	PM	PL	PL	PM
PL	EZ	PS	PM	PL	PL	PL	PL

VII.MATLAB/SIMULATION RESULTS

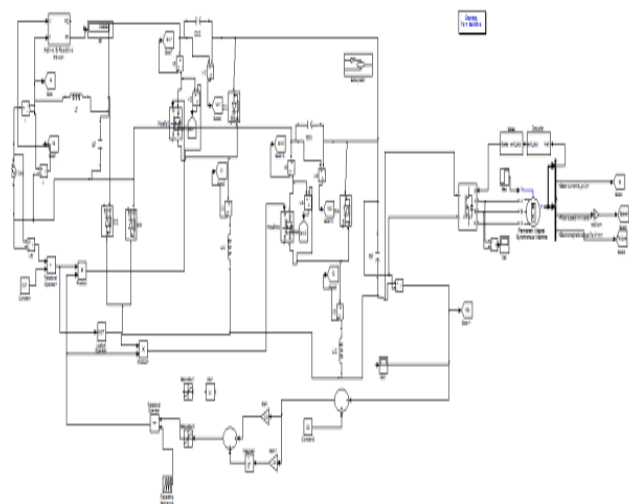

Fig 12 Matlab/simulation model of conventional method using PI controller with BLDC motor

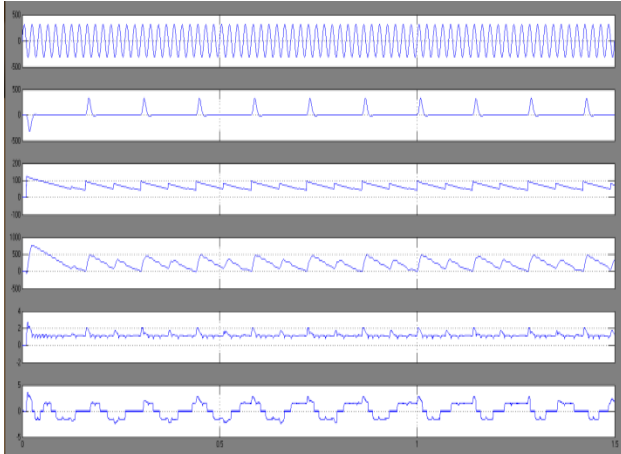

Fig 13 simulation wave form of conventional converter of source voltage, source current, dc link voltage, speed, torque and stator currents at starting $V_{dc}=50v$

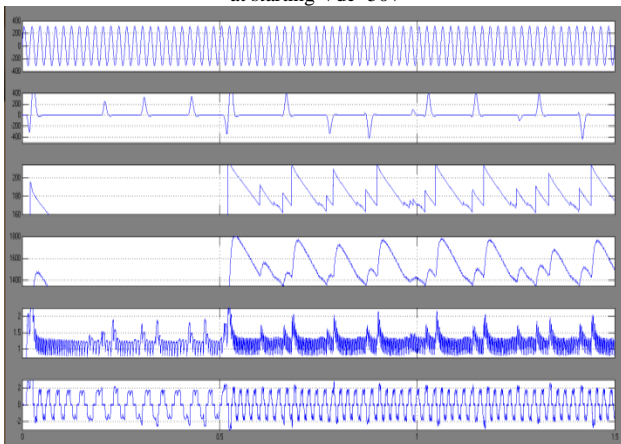

Fig 14 simulation wave form of conventional converter of source voltage, source current, dc link voltage, speed, torque and stator currents during speed control and change in dc link voltage.

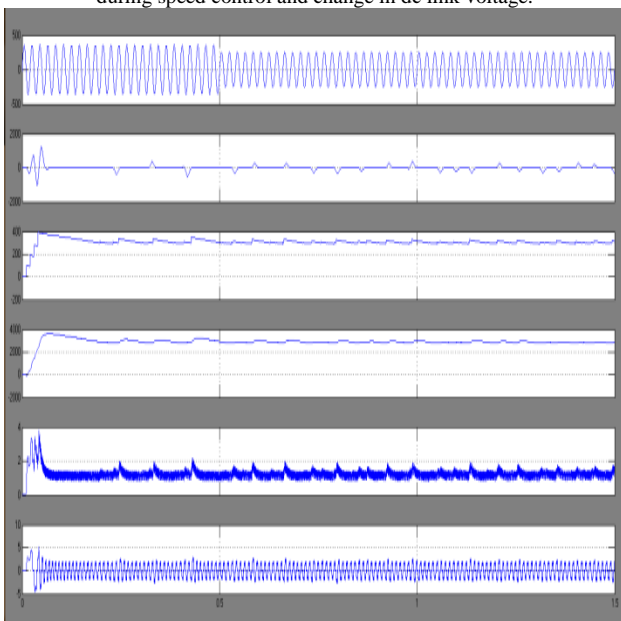

Fig 15 simulation wave form of conventional converter of source voltage, source current, dc link voltage, speed, torque and stator currents during sudden change in supply voltage.

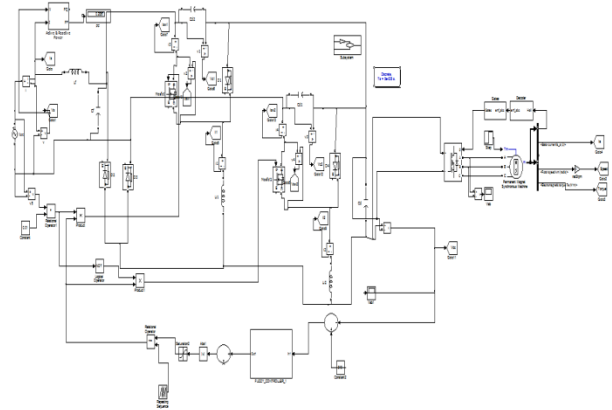

Fig 16 Matlab/simulation model of proposed method using fuzzy logic controller with BLDC motor.

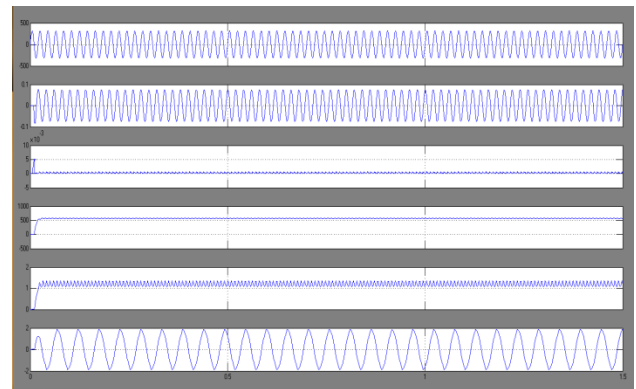

Fig 17 simulation wave form of proposed converter of source voltage, source current, dc link voltage, speed, torque and stator currents.

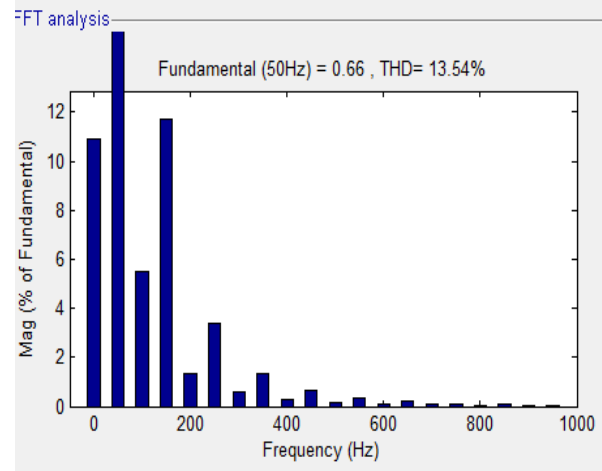
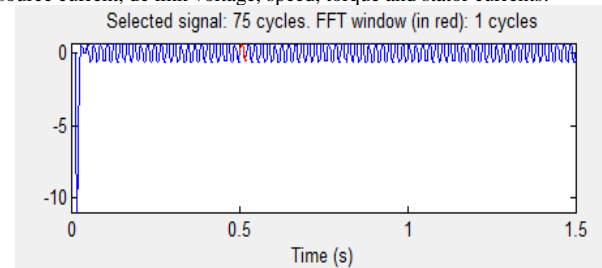

Fig.18.TH D for PI Current.

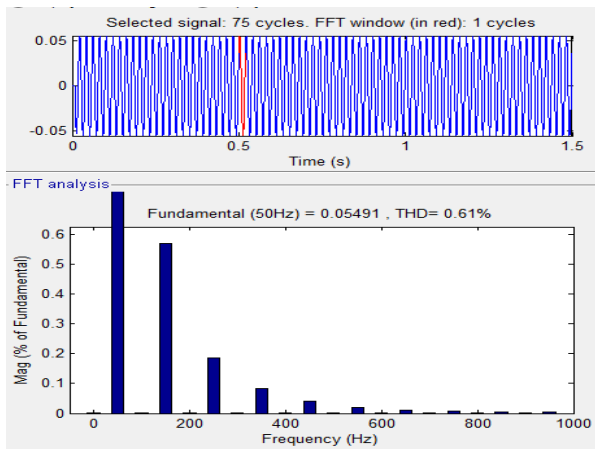

Fig.18.THD for Fuzzy logic controller Current.

VIII.CONCLUSION

A PFC based BL-CSC converter fed BLDC motor drive has been proposed with improved power quality at the AC mains. A bridgeless configuration of a CSC converter has been used for achieving reduced conduction losses in PFC converter. The speed control of BLDC motor and power factor correction at AC mains has been achieved using a single voltage sensor. The switching losses in the VSI have been reduced by the use of fundamental frequency switching by electronically commutating the BLDC motor. Moreover, the speed of BLDC motor has been controlled by controlling the DC link voltage of the VSI. The proposed drive has shown an improved power quality at the AC mains for a wide range of speed control and supply voltages. A PFC-based CSC Converter using hybrid Fuzzy Logic Controller has been proposed for targeting low-power house hold applications. A variable voltage of dc bus has been used for controlling the speed of load. A front-end CSC converter operating in DICM has been used for dual objectives of dc-link voltage control and achieving a unity power factor at AC mains.

REFERENCES

[1].Bhim Singh, Fellow, IEEE, and Vashist Bist, Student Member, IEEE "A BL-CSC Converter-Fed BLDC Motor Drive With Power Factor Correction" IEEE Transactions On Industrial Electronics, Vol. 62, No. 1, January 2015.
 [2] B. Singh, S. Singh, A. Chandra, and K. Al-Haddad, "Comprehensive study of single-phase ac-dc power factor corrected converters with high-frequency isolation," IEEE Trans. Ind. Informat., vol. 7, no. 4, pp. 540-556, Nov. 2011.
 [3] Y. Jang and M. M. Jovanovic, "Bridgeless high-power-factor buck converter," IEEE Trans. Power Electron., vol. 26, no. 2, pp. 602-611, Feb. 2011.
 [4] L. Huber, Y. Jang, and M. M. Jovanovic, "Performance evaluation of bridgeless PFC boost rectifiers," IEEE Trans. Power Electron., vol. 23, no. 3, pp. 1381-1390, May 2008.
 [5] A. A. Fardoun, E. H. Ismail, M. A. Al-Saffar, and A. J. Sabzali, "New "real" bridgeless high efficiency ac-dc converter," in Proc. 27th Annu. IEEE APEC Expo., Feb. 5-9, 2012, pp. 317-323.

[6] A. A. Fardoun, E. H. Ismail, A. J. Sabzali, and M. A. Al-Saffar, "New efficient bridgeless Cuk rectifiers for PFC applications," IEEE Trans. Power Electron., vol. 27, no. 7, pp. 3292-3301, Jul. 2012.
 [7] B. Singh and V. Bist, "An improved power quality bridgeless Cuk converter-fed BLDC motor drive for air conditioning system," IET Power Electron., vol. 6, no. 5, pp. 902-913, May 2013.
 [8] M. Mahdavi and H. Farzaneh-Fard, "Bridgeless CUK power factor correction rectifier with reduced conduction losses," IET Power Electron., vol. 5, no. 9, pp. 1733-1740, Nov. 2012.
 [9] A. J. Sabzali, E. H. Ismail, M. A. Al-Saffar, and A. A. Fardoun, "New bridgeless DCM Sepic and Cuk PFC rectifiers with low conduction and switching losses," IEEE Trans. Ind. Appl., vol. 47, no. 2, pp. 873-881, Mar./Apr. 2011.
 [10] M. Mahdavi and H. Farzanehfard, "Bridgeless SEPIC PFC rectifier with reduced components and conduction losses," IEEE Trans. Ind. Electron., vol. 58, no. 9, pp. 4153-4160, Sep. 2011.
 [11] V. Bist and B. Singh, "A reduced sensor PFC BL-zeta converter based VSI fed BLDC motor drive," Elect. Power Syst. Res., vol. 98, pp. 11-18, May 2013.

Author's Profile:

Ravinuthala Srinivas was born in the year 1992. He obtained B.Tech degree in Electrical and Electronics Engineering from pydah college of engineering & technology. Presently he is pursuing M.Tech (PE) in Sri chundi ranganyakulu engineering college.

B.Subhashini was born in the year 1982. She obtained B.Tech degree in Electrical and Electronics Engineering from Koneru lakshmaiah. College of Engineering. She has Completed M.Tech (PID) in Narasaraopeta Engineering College. Presently she is working as an Asst. professor in Sri chundi ranganyakulu engineering college.

N. Hanuma Naik was born in the year 1981. He obtained B.Tech degree in Electrical and Electronics Engineering from Anil Neerukonda Institute of science and Technology. He has Completed M.Tech in St. Theresa Institute of Engineering and technology. Presently he is working as a Head of the department in Sri Chundi Ranganayakulu Engineering College Ganapavaram; Guntur (Dt); A.P, India.

