

Blood Donors webApplication control using Raspberry pi 2

DAMALLA MOUNIKA¹, P.VAMSHI KRISHNA² & Mr.CHAND RASHEKHAR³

¹M-Tech Dept of ECE, Khammam Institute of and Technology and science Khammam

²Associate Professor of ECE, Khammam Institute of and Technology and science Khammam

³Associate Professor & HOD ECE, Khammam Institute of and Technology and science Khammam

Abstract

Every year the nation requires about 4 Crore units of blood, out of which only a meager 40 Lakh units of blood are available. There are multiple blood banks around the world; however none of them offer the capability for a direct contact between the donor and recipient. This is often a serious disadvantage notably in cases wherever there is associate degree pressing would like of blood. This project aims to beat this communication barrier by providing an immediate link between the donors.

Keywords:Raspberry pi 2, GSM Modem, web Application, Blood Donors.

1. Introduction

Automated online blood bank database: A number of online blood bank databases are available, however none of them offer the capability for a direct contact between the donor and recipient. This is a major drawback particularly in cases where there is an urgent need of blood [1]. Our project aims to overcome this communication barrier by providing a direct call routing technique using Asterisk hardware. A blood bank database is created by collection of details from various sources like Blood banks, NSS, NGO's, hospitals and through web

interface. The data collected will be maintained in a central server. This central server will be associated with a Toll free number that can be used to connect to it. The willingness of donor and the closeness of the donor to the place from where the call is coming are also accounted for in defining this algorithm. Based on the algorithm the most eligible donor is found out. From the server the call from the required person is routed to the eligible donor's number. Such a system considerably cuts down on the overheads involved in referring to an online database and then calling the donors and

verifying their willingness at a time when there is a critical need for the blood [2].

2. Related Work

2.1 Existing system:

Blood bank management system: At present, the public can only know about the blood donation events through conventional media means such as radio, newspaper or television advertisements. There is no information regarding the blood donation programs available on any of the portal. The current system that is using by the blood bank is manual system. With the manual system, there are problems in managing the donors' records. The records of the donor might not be kept safely and there might be missing of donor's records due to human error or disasters [3]. Besides that, errors might occur when the staff keeps more than one record for the same donor. There is no centralized database of volunteer donors. So, it becomes really tedious for a person to search blood in case of emergency. The only option is to manually search and match donors and then make phone calls to every donor. There is also no centralized database used to keep the donors' records. Each bank is having their own records of donors. If a donor makes donation in different hospital, no previous records can be traced except if the donor brings along the donation certificate. Hence, the donor is

considered to be a first timer if they make blood donation in a new place. Without an automated management system, there are also problems in keeping track of the actual amount of each and every blood type in the blood bank. In addition, there is also no alert available when the blood quantity is below its par level or when the blood in the bank has expired.

2.2 Proposed System:

All communication takes place via SMS (Short Messaging Service) which is compatible with almost all mobile types. "Automated Blood Bank" proposes to bring voluntary blood donors and those in need of blood on to a common platform. This project is originated on an android APP, this will help to find the donors. Blood donor will participate in donor list using APP. Suppose if any need in blood, will get the donor list in this APP. Here in this APP, only 3 Blood group (A+, B+, O+) Data base is established. The recent interested donor number will be available in the data base. This project uses GSM modem interfaced to the controller i.e LPC2148. GSM is interfaced through the MAX232 to the Controller [4].

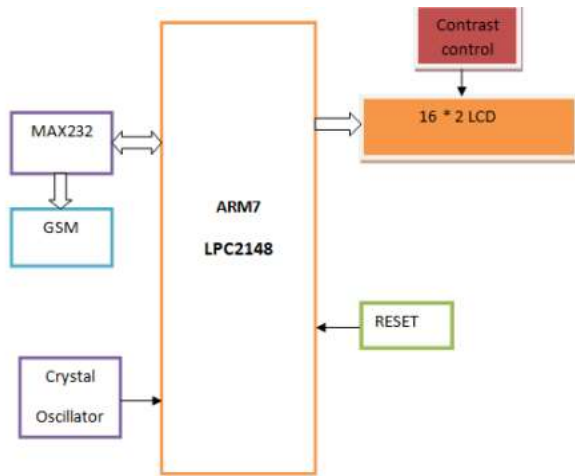

This project uses regulated 5V, 500mA power supply. 7805 three terminal voltage regulator is used for voltage regulation. Bridge type full wave rectifier is used to rectify the ac output of secondary of 230/12V step down transformer [5].

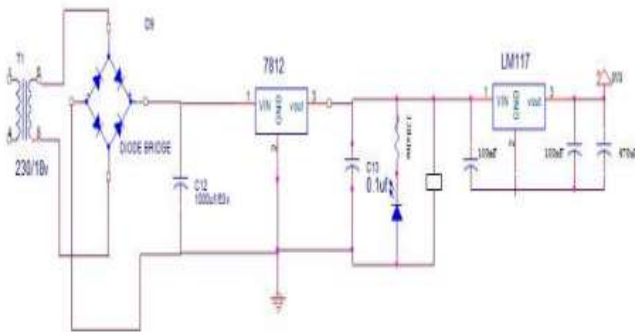

Donor Number Data base

A+	_____
B+	_____
C+	_____



The LPC2148 are based on a 16/32 bit ARM7TDMISM CPU with real-time emulation and embedded trace support, together with 128/512 kilobytes of embedded high speed flash memory.

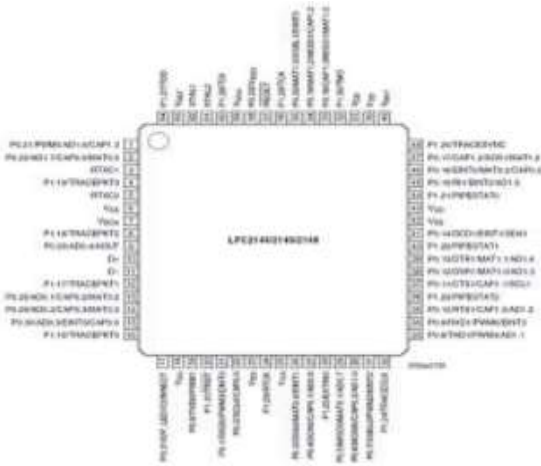

A 128-bit wide memory interface and unique accelerator architecture enable 32-bit code execution at maximum clock rate. For critical code size applications, the alternative 16-bit Thumb Mode reduces code by more than 30% with minimal performance penalty. With their compact 64 pin package, low power consumption, various 32-bit timers, 4- channel 10-bit ADC, USB PORT, PWM channels and 46 GPIO lines with up to 9 external interrupt pins these microcontrollers are particularly suitable for industrial control, medical systems, access control and point-of-sale. With a wide range of serial communications interfaces, they are also very well suited for communication gateways, protocol converters and embedded soft modems as well as many other general-purpose applications [6].

3. Implementation

3.1 METHODOLOGY:

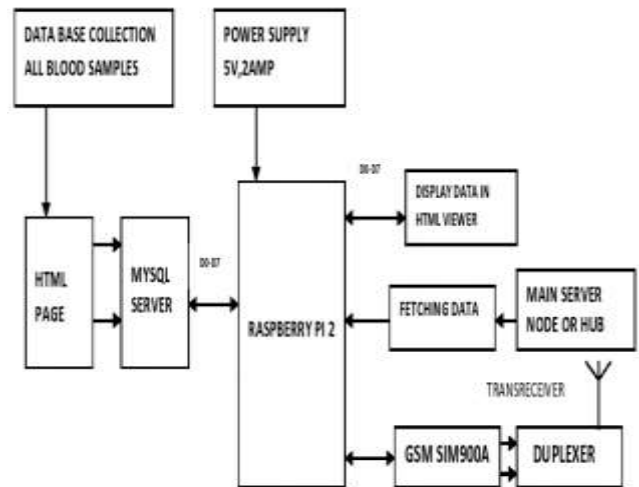

Figure 1 shows the Methodology of the Proposed Design.

Raspberry pi 2 Model B:

The Raspberry-Pi is a series of credit card-sized single-board computers developed in the United Kingdom by the Raspberry Pi Foundation with the intention of promoting the teaching of basic computer science in schools and developing countries [7]. The Raspberry Pi 2 is based on the Broadcom BCM2836 system on a chip (SoC), which includes an ARM cortexv7 900mhz processor, Video Core IV GPU, and was originally shipped with 256 megabytes of RAM. As of 8 June 2015, about five to six million Raspberry Pi's have been sold. The Raspberry Pi 2, was released in February 2015 [8].



Figure 2 shows the Raspberry pi 2.

B. GSM modem SIM 900A:-

A GSM modem is a specialized type of modem which accepts a SIM card, and operates over a subscription to a mobile operator, just like a mobile phone. From the mobile operator perspective, a GSM modem looks just like a mobile phone. When a GSM modem is connected to a computer, this allows the computer to use the GSM modem to communicate over the mobile network. While these GSM modems are most frequently used to provide mobile internet connectivity, many of them can also be used for sending and receiving SMS and MMS messages [9]. Mobile services based on GSM technology were first launched in Finland in 1991.. The SIM900A is a complete Dual-band GSM/GPRS module in a SMT type which is designed especially for Chinese market, allowing you to benefit from small

dimensions and cost-effective solutions. Featuring an industry-standard interface, the SIM900A delivers GSM/GPRS 900/1800MHz performance for voice, SMS, Data, and Fax in a small form factor and with low power consumption. With a tiny configuration of 24mm x 24mm x 3 mm, SIM900A can fit almost all the space requirements in your applications, especially for slim and compact demand of design.

c. Detailed explaining about the functioning of Proposed Design:

“Raspberry-Pi Based Embedded Blood Donating Application” brings the voluntary student’s blood donors to a common platform with the help of educational institutions. These institutions which supports student’s blood service had to share their idea to the hospitals and also to the common people for the getting an awareness of using this system. The mission of this project is to fulfil every blood request in a short span of time via SMS or with a promising web portal which leads to the android application. The vision of this paper is “the provide a better service of every person who is in search of blood”. The motto-“Give blood, Give life”. Noobs is an open source operating system based on the Raspbian optimized for Raspberry pi hardware. It is Linux kernel based operating system which uses ARMV7-A

instruction set with the Broadcom BCM2836 processor [10].

Apache2: It is also known as “Apache HTTP Server” which allows the online distribution of website service using Hyper Text Transfer Protocol (HTTP). Apache2 is used in this project for making net server. PHP5: PHP hyper text pre process is a server-side scripting language designed for the web development. PHP is integrated by web server with a PHP processor module generates the resulting webpage. PHP5 Version is utilized in this project. It supports the standard SQL (Structured Query Language) is a special purpose programming language designed for managing data held in a RDBMS. MySQL is open source RDBMS and free to download and use. VSFTPd: VSFTPd (Very Secure FTP Daemon) is a FTP server which is used to transfer website from computer to Raspberry pi 2. It is free open source software compatible to UNIX like systems including Linux. It is secure and configurable FTP server.

4. Experimental Work



This will open a new window:

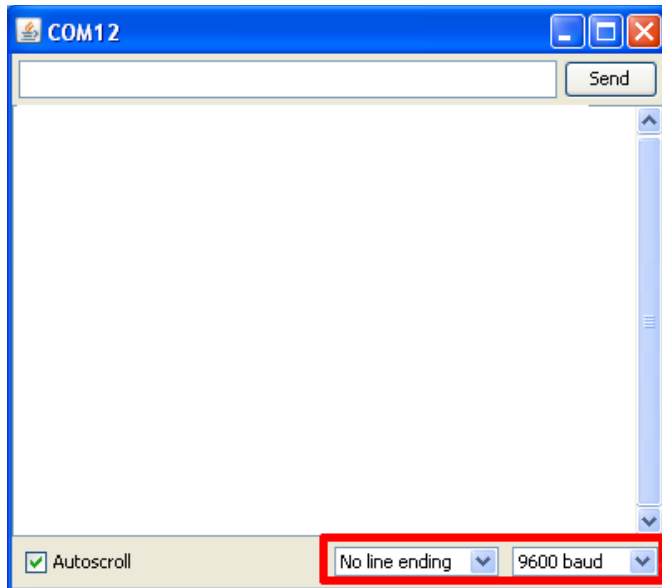

Make sure the line ending is set to newline and the baud rate corresponds to your firmware (115200 mostly), or you will get gibbers. You can enter a command in the upper box (M105 for example), this will result in response from the firmware. The temperature in this case.

Output

When there is urgent need for blood, it may not be possible for people to connect to the internet to look into the online blood database systems that are already in existence. If people adopt this model, the caller is immediately connected to the donor. Consider a SMS based database system in which whenever a SMS is sent to prospective senders, based on the demand. Here there will be a significant delay in the recipient side in viewing the SMS and then responding to it. If

the system that is proposed is setup, only the most eligible

5. Conclusion

Blood is the primary necessity of life. There are different scenarios available for searching blood donors. This proposed system will be one step ahead from the other blood donation systems. Blood recipient can contact the blood donor directly by using this system

6. References

- [1] Arif. M. Sreevas. S. Nafseer. K. and Rahul R., „Automated online Blood bank database“, India Conference (INDICON), Annual IEEE, Print ISBN: 978-1-4673-2270-6, pp. 012 – 017, 2012.
- [2] BalaSenthilMurugan L, Anitha Julian, “Design and Implementation of Automated Blood Bank using Embedded Systems”, International Conference on Circuit, Power and Computing Technologies [ICCPCT], 2015.
- [3] Kopicak L, Nevlud P, Zdralek J, Dubec P, Plucar J, "Remote control of Asterisk via Web Services", 34th International Conference on Telecommunications and Signal Processing (TSP), 2011.
- [4] Peter Marbach, Oliver Mihatsch, and John N. Tsitsiklis, "Call Admission Control and Routing in Integrated Services Networks Using Neuro-Dynamic Programming", IEEE Journal on selected areas in communications, VOL.18, NO.2, February 2000.

[5] R Vanitha M.E, P Divyarani, “BCloud App: Blood Donor Application for Android Mobile”, International Journal of Innovations in Engineering and Technology (IJJET), Vol. 2 Issue 1 February 2013.

[6] Nader Moayeri, Jalal Mapar, Stefanie Tompkins, KavehPahlavan, “Emerging opportunities for localization and tracking”, IEEE Wireless Communications, April 2011.

[7]. Ibrahim. M. and Youssef, M. (2013), 'Enabling wide deployment of GSM localization over heterogeneous phones', Communications (ICC), IEEE International Conference, ISSN: 1550-3607, pp. 6396 - 6400.

[8]. Karan Punjabi, PoojaBolaj, PratibhaMantur, and SnehaWali (2014), 'Bus Locator via SMS Using Android Application', (IJCSIT) International Journal of Computer Science and Information Technologies, ISSN: 0975-9646, Vol. 5 (2), pp. 1603-1606.

[9]. Mohamed Ibrahim and Moustafa Youssef (2011), 'A Hidden Markov Model for Localization using LowEnd GSM Cell Phone', Communications (ICC), IEEE International Conference, ISSN: 1550-3607, E-ISBN: 978-1-61284-231-8, Print ISBN: 978-1-61284-232-5, pp. 1 - 5.

[10]. NeeteshSaxena, and Narendra S. Chaudhari, (2014), 'EasySMS: A Protocol for End-to-End Secure Transmission of SMS', IEEE

Transactions on information forensics and security, VOL. 9, NO. 7, ISSN: 1556-6013, pp. 1157 - 1168.

[11]. Spyropoulos. B., Botsivaly. M., Tzavaras. A., and Spyropoulou, P (2009), 'Towards digital bloodbanking', ITU-T Kaleidoscope: Innovations for Digital Inclusions, .K-IDI. E-ISBN : 978-92-61-12891-3, Print ISBN: 978-92-61-12891-3, pp.I- 8.

Authors Profiles



DAMALLA MOUNIKA

B.Tech in khammam Institute Of Technology And Science, Khammam, percentage is 72.35%, year of completed April 2014.

M.Tech[ES] (EMBEDED SYSTEMS)

College: khammam Institute of and Technology and science (KITS), Khammam.

Mail id: pretty.mounika431@gmail.com

Phone number: 9553275419



P. VAMSHI KRISHNA.

Experience: 5 years.

Qualification: M.Tech from JNTU, Hyderabad.

Designation: Associate Professor.

Working: khammam institute of technology and science (KITS), Khammam.

Email-d: vamshi9@gmail.com

Phone Number: 8985506287



Mr. CHANDRASHEKHAR.

Working: N.ChandraShekhar completed his M.Tech with electronics and communication engineering. He has published more than five international journals. Currently he is a research Scholar in JNTU, Hyderabad and working as Associate Professor & Head of the department for ECE in Khammam Institute of Technology and Science.