

New Three-Phase Interleaved Single-Stage PFC AC-DC Adapter with an Intense Bird

1. J.SWATHI,2. D.CHANDRA SEKHAR

¹PG Scholar, Department Of EEE, Sri Sai Educational Society's Group of Institutions, Kodad.

²Assistant Professor, , Department Of EEE, Sri Sai Educational Society's Group of Institutions, Kodad.

ABSTRACT

In this project is addressed to the function of AC-DC converter operation and its modulation techniques. In recent years to developing pulse width modulation to used power conversion process. The many techniques of PWM to improve power production program. In this project focused Addresses a cost-effective, flexible solution of improvement of efficiency to three phase AC-DC converter using SVPWM(space vector pulse width modulation).The proposed converter has a better efficiency, especially under light-load condition and it was explained that this is because the energy from the output inductor can always be used to ensure that the very top and the very bottom switches can be turned ON with ZVS due to a discharge path that is introduced by its flying capacitor.

Keywords: AC-DC converter; power factor correction; space vector phase-shifted modulation; three- phase converter; three-phase system; transformer circuit

1. INTRODUCTION

Conversion of power from one form to the other is an ultimate task in renewable energy applications in order to meet the power necessities of the utilities. Special switching components are used in this type of power conversions. Power converters have four basic

categories of components, semiconductor, switches,gating and control systems, inductive components and capacitive components. The inductive and capacitive components are used to energetically store the electrical energy for circuit power flow filtering, damping and transformation.

Switch gating and control system is used to control the ON and OFF states of the switches so that the circuit operates in a stable, efficient and productive condition. Innovative improvements in the semiconductor switch designs contain the driving force for the advancements and implementations of power conversion stages in stand-alone or grid connected power conversion systems.

AC-DC power converter is forced to be executed with input power factor correction to complete with harmonic standard recognition for utilizing the following strategies.

- The first strategy is to add inductors to filter out Low frequency input current harmonics.this type converter is heavy and bulky.

The second method,use two stage converter. Stage 1: preregulator (control input current)

Stage 2: DC-DC converter (control

DC bus voltage), its contain two separate switch mode converter to increase cost and size.

- The Third method to placed PFC and isolated Dc-Dc conversion technique. This method reduced the cost, but it worked two separate switch mode converter. The above three inverter do not produce low frequency input current harmonics.

The single stage of three phase converter operates with discontinuous current. So the current stress is increased. This system needs to filter the high frequency harmonics. The above drawbacks are overcome for this project. In this project to implement the power factor correction of the AC-DC power supplies by the PWM techniques. In this project used to space vector PWM techniques to convert AC-DC. In this SVPWM method used for the improvement of harmonic reduction to increase the efficiency of the converter. In this system provide the output current is continuous for almost all load ranges, a DC bus voltage is used to reduce amount of more than 450V for all load conditions and a superior input current harmonic content from adding the interleaved structure. In this project, a new interleaved single stage of three-phase AC-DC converter that uses the flying capacitor structure with SVPWM

to improve efficiency of the converter in the light load condition.

Another interleaved single-stage of three-phase PFC AC-DC converter used to flying capacitor structure with space shift pulse width modulation is the other method. This project is used to improve efficiency of the converter particularly in light load conditions. Its PWM method modified to implement the efficiency from the SVPWM of this converter. The intersections between the reference voltage waveform and the carrier waveform give the opening and closing times of the switches. Pulse-width modulation (PWM) is an execution where the obligation ratio of an energizing waveform controlled by another input waveform.

PWM is used to adjust the voltage applied to the motor. Changing the duty proportion of the switches changes the speed of the motor. The more extended the pulse is shut contrasted with the opened periods, the higher the force supplied to the load. The change of state between opening (OFF) and closing (ON) is fast, so that the normal force liberality is low contrasted with the force being conveyed. PWM amplifiers are more efficient and bulky than linear power amplifiers. In addition, linear amplifiers that convey vitality continuously rather than through pulses have most extreme power appraisals than PWM amplifiers.

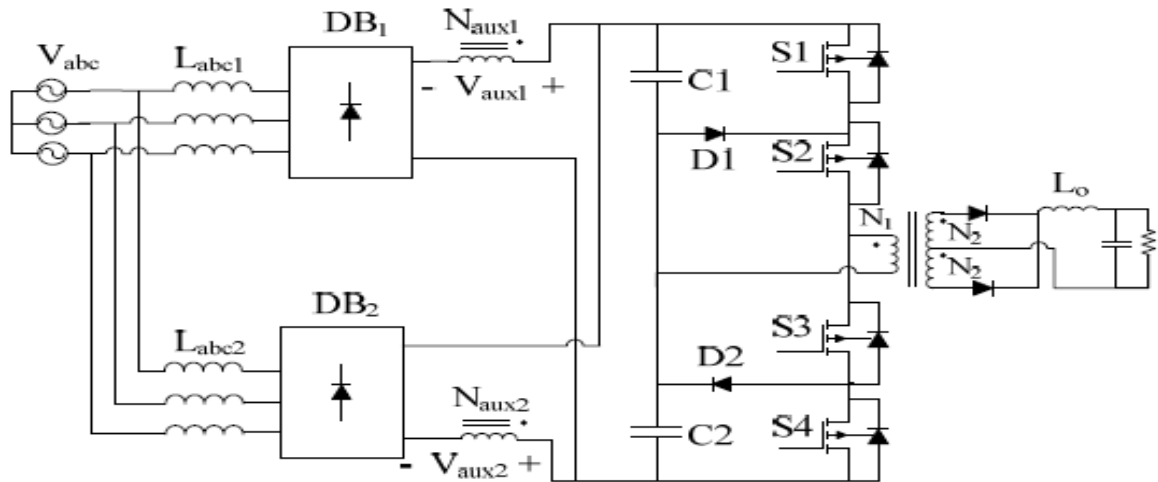

Figure 1. Three phase AC-DC converter

The Single stage of three-phase PFC AC-DC converter to use a passive method to contain large capacitor and inductor. So the system goes to large size and complexity. It required to separate switch mode capacitor. There is a need an extensive input filter, to filter out the ripples at this current is irregular. The system has high output ripples so the output current must be discontinuous. This system needs for input filtering due to the large amount of ripples. Single-stage power factor correction converter (SSPFCC) that have PFC and isolated AC-DC converter in the power converter. So it is less complex and less expensive than a two-stage

converter.

2. THREE-PHASE AC-DC CONVERTER WITH FLYING CAPACITOR

In Figure 2 explain the power conversion of Ac source to DC side. Three phase power supply applied to the two diode bridge circuit through the line impedance and cross connected to the auxiliary winding and its connect to switching circuit and flying capacitor loop its output connected to the transformer and load side.

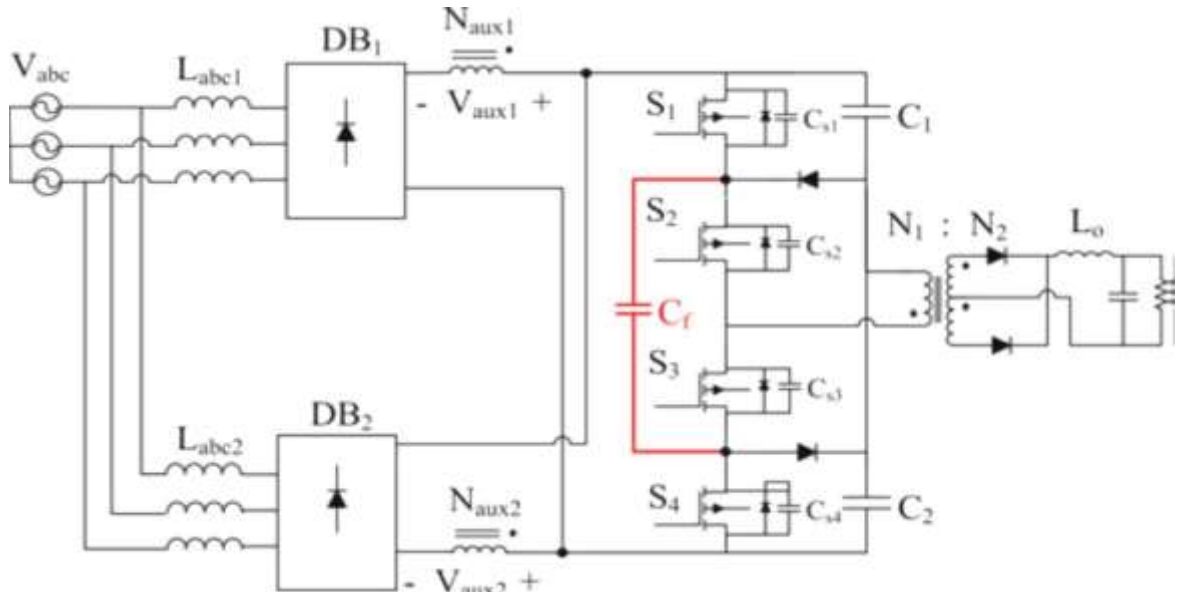

Figure 2. Single stage of three-phase AC-DC converter with flying capacitor

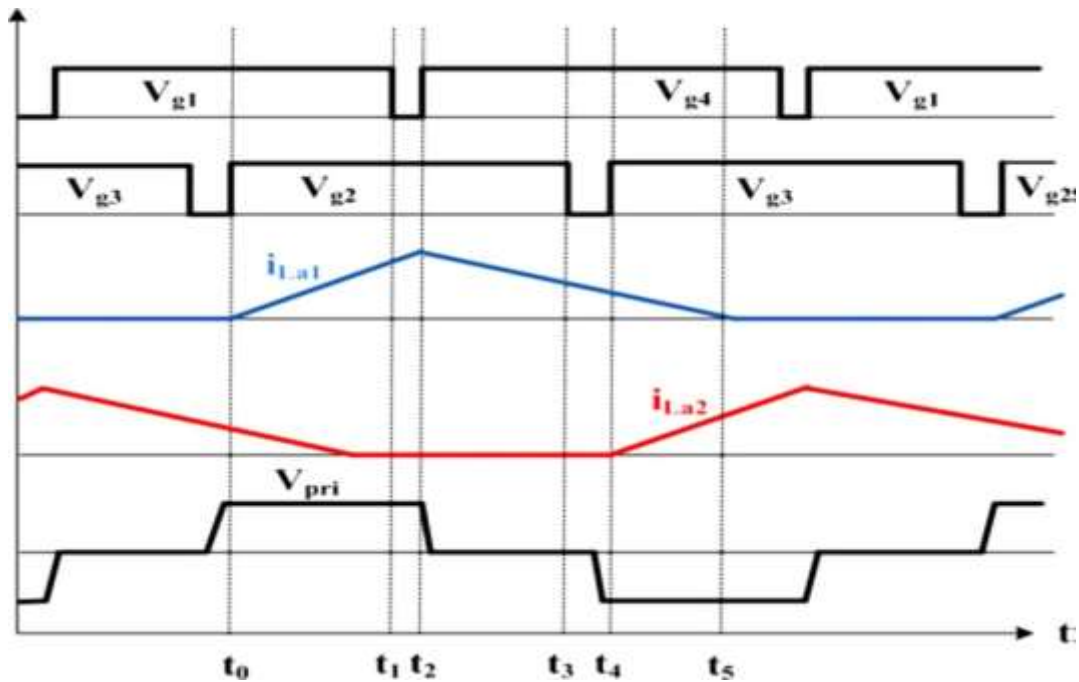

Figure 3. Typical Waveforms Of Ac-Dc Converter.

The Single stage of three-phase AC-DC converter utilizes auxiliary windings. The auxiliary windings are taken from the converter transformer to act as "magnetic switches". To cross out the DC bus capacitor voltage so the voltage is to appears across the diode bridge output is zero. Auxiliary Winding 1 ($N_{aux1}/N_1 = 2$) cancels out the DC bus positive. so, the output voltage of Diode Bridge 1 (DB1) is zero. The input inductor currents L_{a1} , L_{b1} , and L_{c1} rise. Auxiliary Winding 2 $N_{aux2}/N_1 = 2$ cancels out the DC transport voltage when the essential voltage of the primary transformer is negative, so the output voltage of Diode Bridge 2 (DB2) is zero. The input inductor currents L_{a2} , L_{b2} , and L_{c2} rise. When there is no voltage over the principle transformer primary winding, the aggregate voltage over the DC bus capacitors shows up at the output of the diode bridges and the input current falls since this voltage is more prominent than the input voltage. so, the input currents are irregularly.

The "magnetic switches" to cancel

the DC bus capacitor voltage. so the voltage is shows over the diode bridge output is zero. When the essential voltage of the essential transformer is negative. When there is no voltage over the principle transformer primary winding, the aggregate voltage over the DC bus capacitors shows up at the input currents falls and the output of the diode bridges. Since the voltage is more highest than the input voltage. If the input currents are spasmodic, then they will be normally sinusoidal.

3. PROPOSED INTERLEAVED SINGLE-STAGE OF THREE-PHASE AC-DC CONVERTER WITH FLYING CAPACITOR

The proposed interleaved single stage of three phase power factor corrected AC-DC converter with flying capacitor explain in terms of 5 modes of operation. The modes of operation explain the conversion AC-DC.

MODE OF OPERATION

(a) Mode 1 ($t_0 < t < t_1$):

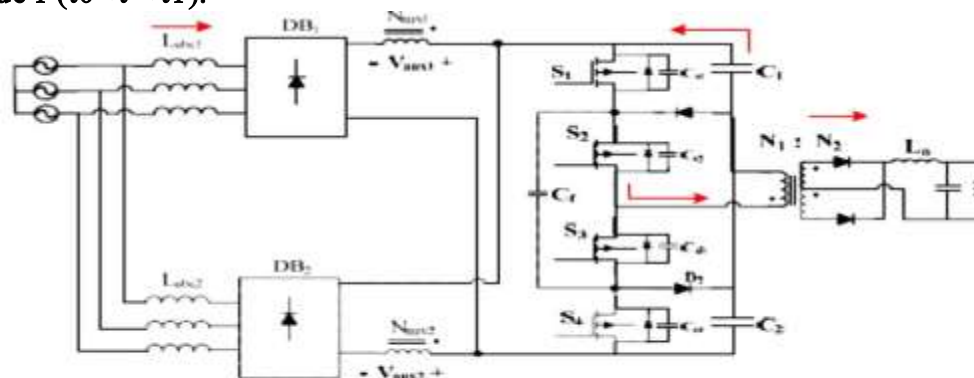

(a) Mode 1 ($t_0 < t < t_1$)

During this interval, switches S1 and S2 are ON. In this mode, energy from DC bus capacitor C1 streams to the output load. Because of magnetic coupling, a voltage shows up crosswise

over Auxiliary Winding 1 is dropped the aggregate DC bus capacitor voltage. The voltage at the diode bridge output is zero and the input currents in La1, Lb1, and Lc1 rise.

(b) Mode 2 ($t_1 < t < t_2$):

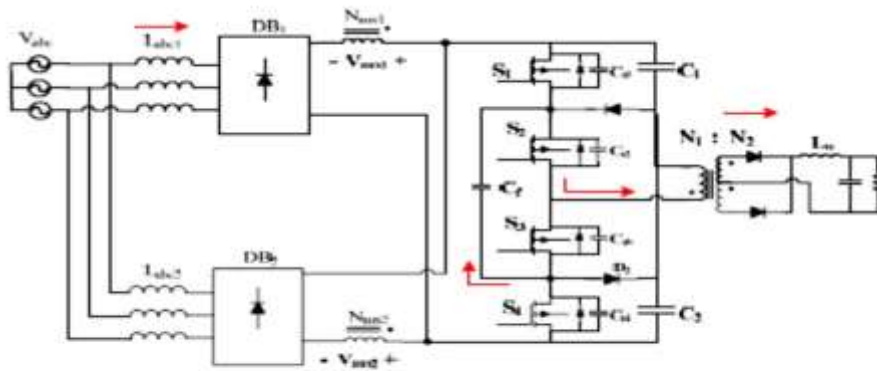

(b) Mode 2 ($t_1 < t < t_2$)

In mode 2 S1 is OFF and S2 remains ON. Capacitor CS1 charges and capacitor CS4 discharges through CF until the voltage across CS4, the output capacitance of S4, is clamped to zero.

The energy stored in the input inductor during the previous mode begins being moved into the DC transport capacitors. This mode ends when S4 turns on with ZVS.

(c) Mode 3 ($t_2 < t < t_3$):

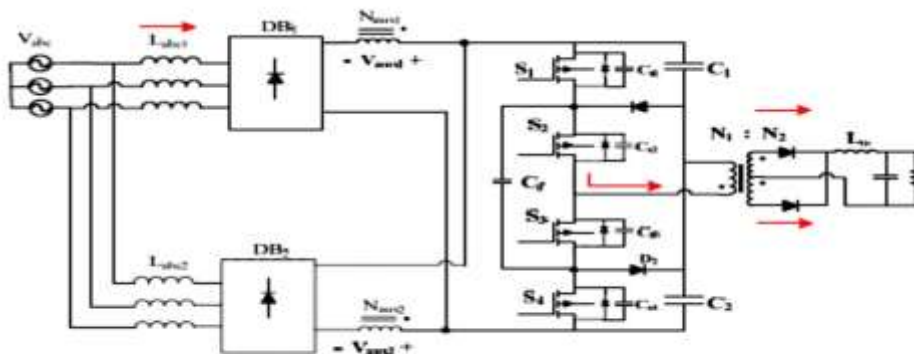

(c) Mode 3 ($t_2 < t < t_3$)

In Mode 3, S1 is OFF and S2 stays ON. The energy stored in input inductor L1 during Mode 1. It is transferring into the DC bus capacitors. The voltage that shows up cross wise over Auxiliary Winding 1 is zero. The essential current

of the main transformer circulates through D1 and S2. With respect to the converter's output section and the load inductor current freewheels in the auxiliary of the transformer.

(d) Mode 4 ($t_3 < t < t_4$):

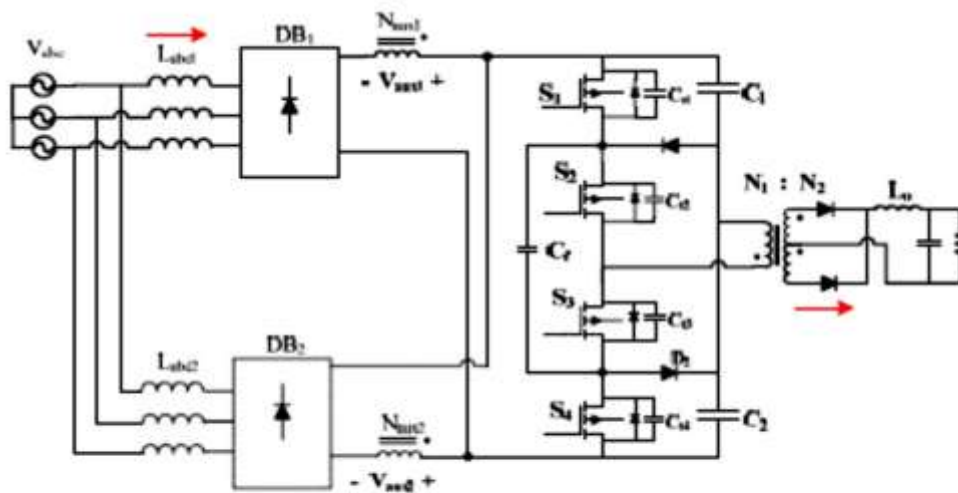

(d) Mode 4 ($t_3 < t < t_4$)

In mode 4 S1 and S2 are OFF. The energy stored in L1 continues to be transferred into the DC bus capacitor. The essential current of the transformer discharges the output capacitor of CS3. If there is enough energy in the leakage inductance, the essential current will totally release inductance, the capacitor of CS3 and current will flow through the diode of S3. This current also charges C2 through the diodes of S3 and S4. Switch S3 is switched ON at the end of this mode.

(e) Mode 5 ($t_4 < t < t_5$):

In this mode, S3 and S4 are ON and energy flows from capacitor C2 to the load. A voltage appears across Auxiliary Winding 2 that is equivalent to the DC voltage. However with the inverse extremity to cancel out the DC bus voltage. For the rest of the duty cycle, the converter goes through Mode 6 to mode 10, which are identical to Mode 1 to mode 5 except that S3 and S4 are ON instead of S1 and S2 and DB2 conducts current instead of DB1.

The computation of the input currents i_{L1} and i_{L2} , comparing to each set of input inductors. The inductor having a spasmodic current.

However, by selecting appropriate values for $L_{a1} = L_{b1} = L_{c1}$ and $L_{a2} = L_{b2} = L_{c2}$, two inductor currents such as i_{La1} and i_{La2} can be made to extend beyond

each other so that the input current can be made continuously and it is reducing the size of input filter significantly.

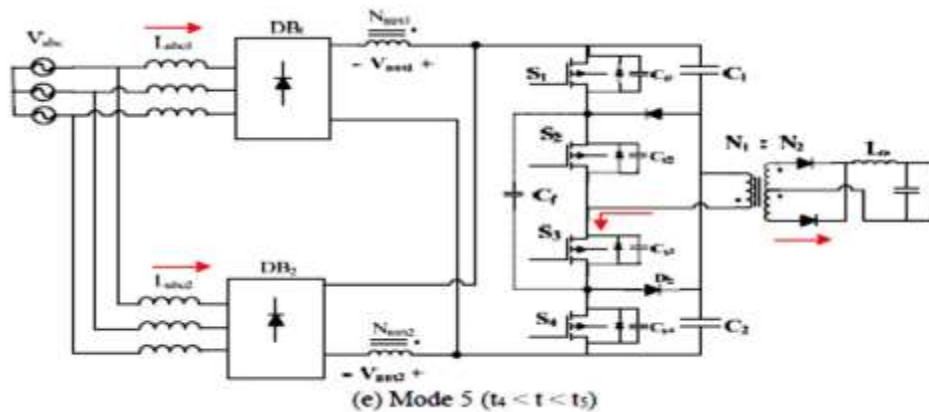

The characteristic of 180° stage contrast between the streams in L1 and the current and flows in L2 as one arrangement of current flows rises when the transformer essential is inspired with a positive voltage and the other set ascents when the transformer essential is awed with a negative voltage. It should be noted standard phase-shift PWM can be implemented in the converter and thus the standard phase-shift PWM IC can be used to generate the gating signal. This can be seen from mode 5 and the model circuit diagram. Switches S2 and S3 are not allowed to be ON at the same time and switches S1 and S4 are not allowed to be ON simultaneously as well.

The converter is in an energy-transfer mode. Whenever switches S1 and S2 are ON or S3 and S4 are ON. The freewheeling mode of operating switches S1 and S3 or S2 and S4 are ON. The sequence of alternating energy transfer and freewheeling modes that occur during a switching cycle

corresponds to the same sequence of modes that exists in a standard two-level phase-shift PWM full-bridge converter. The proposed interleaved topology with flying capacitor can guarantee a ZVS turn-on for its very top and very bottom switches in a way that the converter presented in cannot. To understand why this is so, first consider a standard two level ZVS-PWM DC-DC full-bridge converter operating with phase-shift PWM. For this converter, the leading leg switches (switches that are turned ON when the converter enters a freewheeling mode of operation) of this converter can be turned on with ZVS. This is due to the fact that the transformer primary current is dominated by reflecting output inductor current during this transition so that there is sufficient energy available to turn ON the leading leg switches with ZVS.

The significance of N affects the primary-side DC bus voltage. It determines how much reflected load current is available at the transformer

primary to fulfill the bus capacitors. If N is low, the primary current may be too high and thus the converter will have more conduction losses. If N is very high, then the amount of current circulating in the primary-side is reduced, but the primary current that is available to discharge the DC-link capacitors may be low and thus DC bus voltage may

The output inductor should be considered. So the output current is made to be consistently under most operating conditions, if conceivable. The minimum value of L_0 should be the value of L_0 with which the converter's output current will be constantly on the when the converter is operating with a maximum input voltage, minimum duty cycle and minimum load. On the other hand, the value of L_0 cannot be too high as the DC bus voltage of the converter may become excessive under very light load conditions. The value for L_1 and L_2 should be low enough to ensure that their currents are fully discontinuous under every single working conditions, yet not all that low as to result in excessively high peak currents. It should be noticed that the input current is entirety of inductor currents i_{L1} and i_{L2} which are both spasmodic. However, by selecting suitable qualities for L_1 and L_2 in such a way that two inductor currents such as i_{La1} and i_{La2} have to overlap each other, the input current can be made.

The flying capacitor is charged to half of the DC bus voltage. When the converter is operated with phase-shift PWM control. CF is generally decoupled from the converter except during certain

become excessive under certain operating conditions (i.e. high line). The minimum value of N can be found by allowing for the case when the converter must operate with minimum input line and the minimum primary-side DC bus voltage and maximum duty cycle. If the converter can produce the required output voltage.

switching transitions, such as when S_1 is turned off to start Mode 2 and when S_4 is turned off during the equivalent mode later in the switching cycle; therefore there is little opportunity for CF (flying capacitor) to charge and discharge during a switching cycle.

4. SIMULATION RESULTS

The output of the single stage three-phase AC-DC converter output will be shown at the following diagram. In this figure 4.1 where the x-axis represent time in seconds and y-axis represent output AC voltage, input AC voltage and DC voltage respectively. AC-DC converter using space vector PWM was presented in this work. In this paper, the operation of the converter was clarified and its achievability was affirmed with experimental results obtained from a prototype converter.

The following diagram are run and built with matlab simulation and its fully declare the simulation process and output.

The above diagram are simulation diagram of three phase single stage PFC AC-DC converter and its run with matlab software to produce following output and input waveform

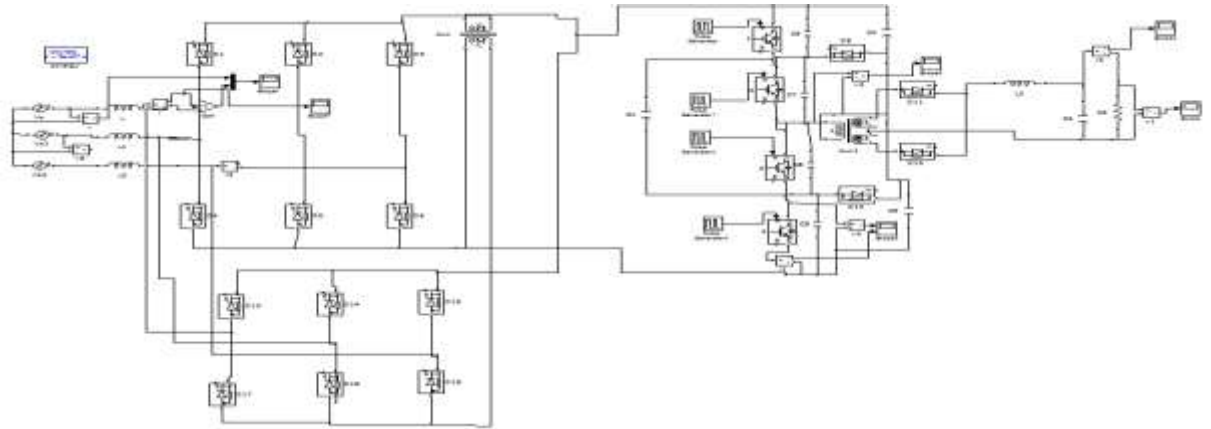
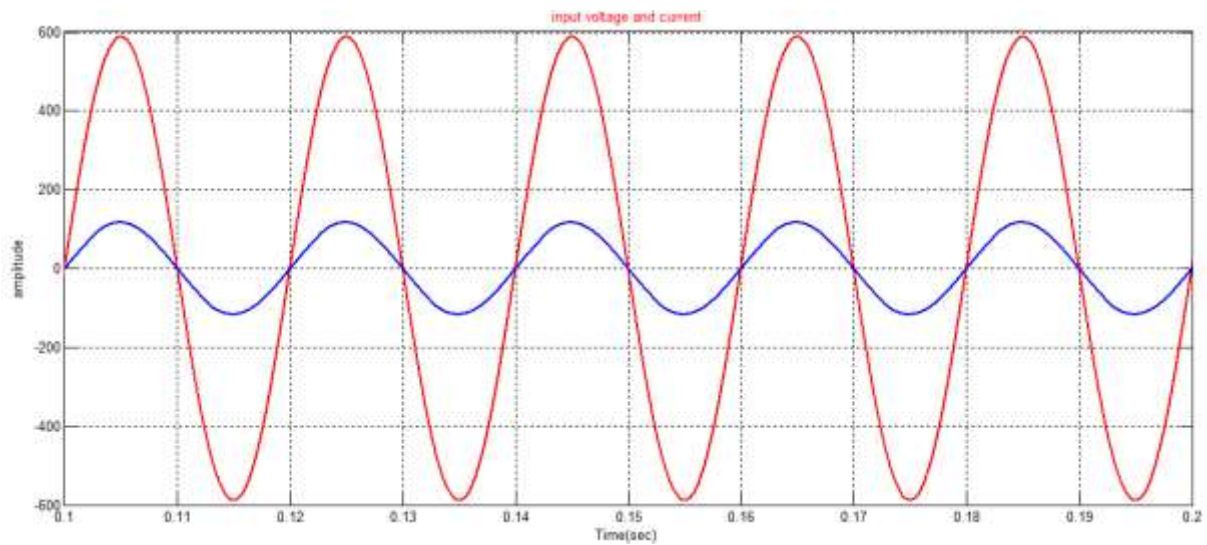
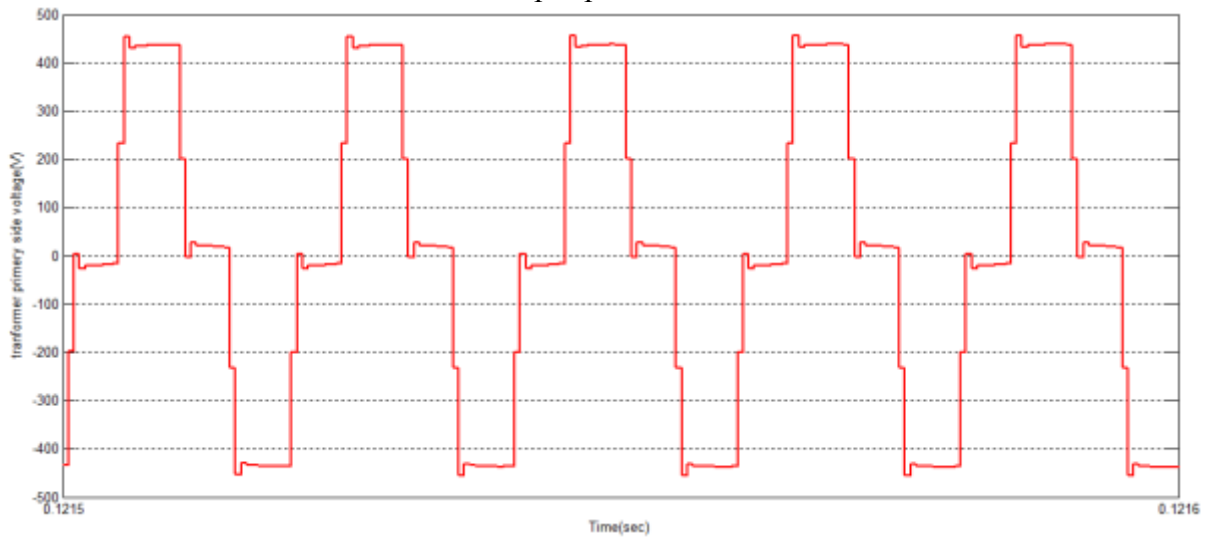

Figure 4. Simulink diagram of single stage three phase AC-DC converter



In put power factor



Voltage across primary winding of transformer

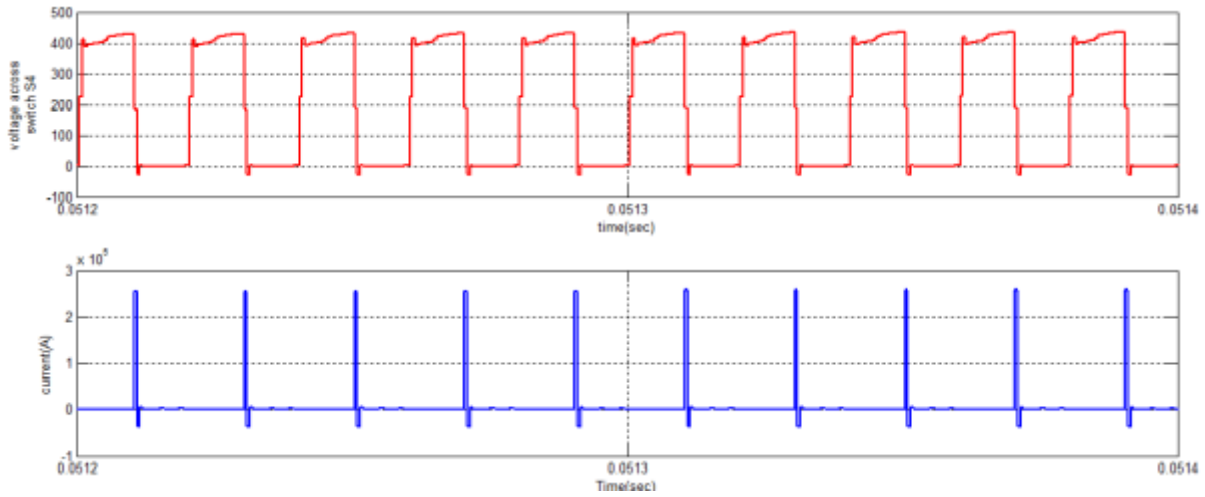

Voltage and current in switches

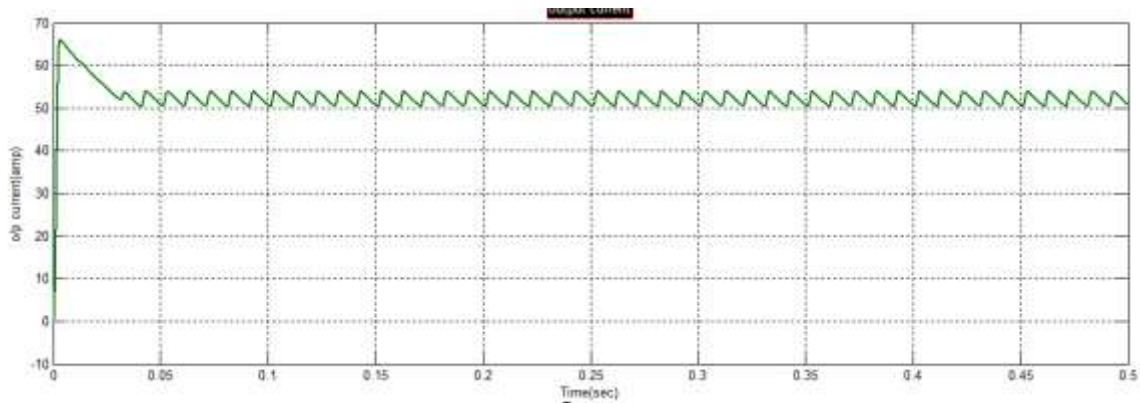

Load Current

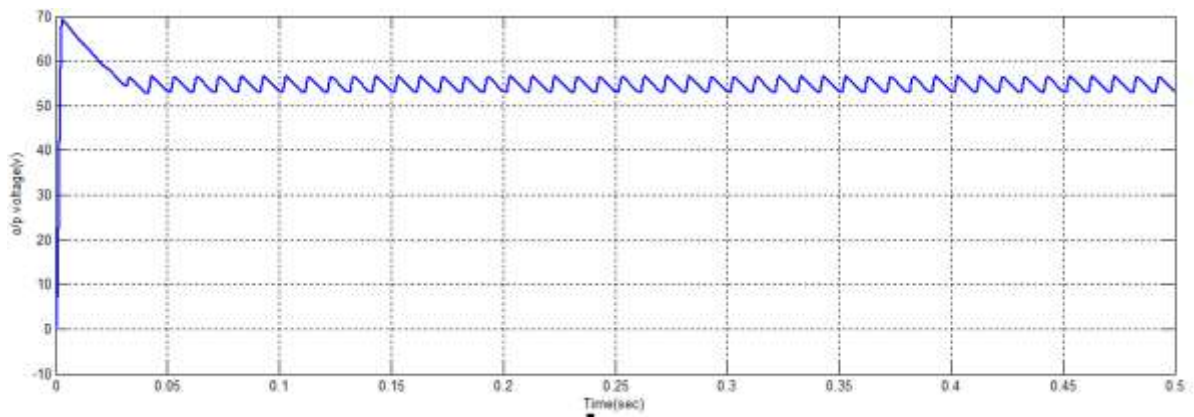

Output voltage

The efficiency of the new converter is very high. It was shown that the proposed converter has a better efficiency, especially under light-load conditions.

1. CONCLUSION

A new interleaved single-stage of three phase very top and very bottom switches can be turned ON with ZVS, due to a discharge path is introduced by its flying capacitor. In this method produce high efficiency and PFC values compare to phase-shift PWM method. The design of the converter is allowed greater flexibility and ultimately improved performance with the source harmonics is reduced from 0.70% to 0.23% it maintains greater enhancement in the power factor.

References

- [1] Golbon N. and Moschopoulos G. (2012). 'A Low-Power Ac-Dc Single-Stage Converter With Reduced Dc Bus Voltage Variation', *IEEE Trans. on Power Electron.*, Vol. 27, No.8, pp. 3714-3724.
- [2] Houldsworth J., and Grant D. (1984), 'The Use Of Harmonic Distortion To Increase The Output Voltage Of A Three-Phase PWM Inverter', *IEEE Trans Ind Appl IA-20*: 1224-1228.
- [3] Hamdad F S. and Bhat A K S.(2014). 'A Novel Soft-Switching High-Frequency Transformer Isolated Three-Phase AC To DC Converter With Low Harmonic Distortion', *IEEE trsans, power Electron*, Vol. 19, No 1, pp. 35-45.
- [4] Kammarn U., Chunkag V. (2005). 'Analysis and design of a modular three phase Ac-to- dc converter using CUK rectifier module with nearly unity Power factor and fast dynamic response', *IEEE Trans on Power Elec.*, Vol. 24, No. 8. pp. 2000-2012.
- [5] Kim H S., Baek J W., Ryu M R., Kim J H., and Jung J H. (2014). 'He high efficiency isolated ac-dc converter using the three-phase interleaved LLC resonant converter employing the Y-connected rectifier,' *IEEE Trans. Power Electron.*, Vol. 29, No. 8, pp. 4017-4028.
- [6] Kwon J M., Choi W Y., Kwon B H.(2011). 'Single-stage quasi-resonant flyback converter for a cost-effective PDP sustain power module,' *IEEE Trans. on Industrial Elec.*, Vol. 58, No. 6, pp. 2372-2377.
- [7] Limits for Harmonic Current Emission (Equipment Input current>16 A per phase), IEC 1003-3-2 Int. , std., 1995.
- [8] Narimani M. and Moschopoulos, (2014). "A new interleaved three-phase single-stage pfc AC-DC converter," *IEEE Trans. Ind Electrol* Vol. 61, No. 2 pp. 648-654.
- [9] Suraywanshi H M., Retake M R., Thakre K M., and Borghate V B.(2008). 'Unity-power-factor operation of three phase ac-dc soft switched Converter based on boost active clamp topology in modular approach', *IEEE Trans. on Power Elec.*, Vol. 23, No. 1., pp. 229-236.

- [10] Sheng H., Wang F., and Tipton WC. (2012). 'A fault-detection and protection Scheme for three-level dc-dc converters based on monitoring flying Capacitor voltage,' *IEEE Trans. Power Electron.*, Vol. 27, No. 2, pp. 685-697
- [11] Sun J., Grotstollen H. (1996). Optimized space vector modulation and regular-sampled PWM: a reexamination. In: Proceedings of Recent Advances in Pulse Width Modulation Techniques and Multilevel Inverters (World Academy of Science, Engineering and Technology. *International Journal of Electrical, Computer, Energetic, Electronic and Communication Engineering* Vol. 8, No. 3.
- [12] Tamyurek B. and D A Torrey, (2011). 'A three-phase unity powers factor single-stage ac-dc converter based on an interleaved fly back topology,' *IEEE Trans. Power Electron.*, Vol. 26, No. 1, pp. 308-318.
- [13] Wang C M. (2008). 'A novel single-stage high-power-factor electronic last with symmetrical half-bridge topology,' *IEEE Trans. Power Electron.*, Vol. 55, No. 2, pp. 969-972.
- [14] Xie Y., Fang Y. and Li Y. (2005). 'Zero voltage switching three-level

three-phase high- power-factor rectifier, "in process', *IEEE IECON* 2007, 1319-1327..

AUTHOR'S PROFILE:

1. J. SWATHI

PG Scholar, Department Of EEE. Gandhi Academy Of Technical Education, Ramapuram (kattakommu Gudem), Chilkur(M), Kodad, Telangana 508206.

2. D.CHANDRA SEKHAR

Dharamalla.ChandraSekhar- was born in telangana, INDIA in 1982. He received his B.Tech degree from VNR VJIET JNTU Hyderabad in 2004,M.Tech degree in Power Electronics from JNTU Hyderabad in 2009.He persuing his Ph.D degree from JNTU Ananthapur in the area of six phase transmission syastem Since July 2004-Sept 2008 he had been worked as Assistant Proffesor in the Department of EEE at Hi-Tech Engineering College. Since October-2008 he was been working as a Assistant Professor& Head of Department of Electrical and Electronics Engineering in SSESGL ,Kodad JNTUH, Telangana. His areas of interest are Electrical Machines, Power Electronics and Drives,Power Systems .