Analysis of Mobile ECG Monitoring System through Wearable Non-Contact Armband



Akram Hatem Saber
M.E., ECE Department
College Of Engineering, Osmania University,
India



Dr. B. RajenderaNaik
Head of Department, ECE Department,
College Of Engineering, Osmania University,
India

ABSTRACT:

The review proposes a wearable, low power setting careful ECG checking framework facilitated certain dynamic sensors of the propelled cell phone with a self-created ECG sensor. Unfortunately, most accessible social insurance gadgets don't give clinical information, for example, data in regards to patients' heart exercises. Numerous specialists have attempted to take care of this issue by imagining wearable heart checking frameworks with a mid-section strap or wristband, yet their exhibitions were not possible for reasonable applications. Along these lines, the point of this review is to assemble another framework to screen heart movement through ECG signals. The proposed framework comprises of capacitive-coupled cathodes implanted in an armband. It is thought to be a dependable, hearty, and low-control transmission ECG observing framework. The dependability of this framework was accomplished by the watchful arrangement of sensors in the armband. Bluetooth low energy (BLE) was utilized as the convention for information transmission; this convention was proposed to build up the low-control transmission framework. For heartiness, the proposed framework is outfitted with investigation abilities e.g., ongoing pulse identification and a channel calculation to overlook diversions from body developments or commotion from the earth. The test happens demonstrated the execution of proposed framework in upgrading conclusion precision for arrhythmias and recognizing the most broadly perceived uncommon ECG outlines in different activities.

Keywords: Analog Front-End (AFE); Bluetooth low energy (BLE); Electrocardiography (ECG); Micro Control Unit (MCU); Secure Digital (SD).

INTRODUCTION:

M-HEALTH or mobile wellbeing is a term that is utilized to portray social insurance administrations with the help of

cell phones. The M-wellbeing checking and indicative restorative gadgets market is at present in its early stages however is relied upon to become quickly because of market

interest for remote observing frameworks. As indicated by another report from Transparency Market Research, the market for versatile wellbeing checking and diagnostics will develop at a compound yearly development rate of 43.3 percent from 2013 to 2019. This will put the market at \$8 billion in 2019. Expanded games exercises and mindfulness about wellbeing and wellness is a portion of the variables that are foreseen to fuel the development of this market. Shockingly, appeal does not naturally ensure that the gadgets accessible in the market are solid and reliable.

Different reviews have been directed identified with the advancement of remote medicinal services frameworks, particularly heart rate observing frameworks. The vast majority of these reviews have concentrated on four fundamental themes: sensor innovation, wearable frameworks, signal handling, and portable observing frameworks. Scientists have attempted to create sensors that can detect bio-signals without producing symptoms or diverting clients, yet these were still not able to give an abnormal state of exactness. The standard technique in a healing facility to quantify an electrocardiogram (ECG) is to utilize a 12-lead ECG. In a customary 12-lead clinical ECG framework, cathodes are fastened to particular parts of the mid-section, arms, or hands and legs. Despite the fact that this guarantees profoundly exact outcomes, it frequently requires a lot of readiness and a specialist to append the anodes to the patient's body. These cathodes additionally require skin arrangement and conduction gel to decrease contact impedance. The primary

issue with this strategy is that it can't be utilized for long haul estimation as a result of the confinement of the gel and confused wiring. In light of this, different strategies have been given to conquer these shortcomings, for example, utilizing dry anodes or noncontact terminals.

Cardiovascular diseases are the standard purposes behind death around the globe. The reliable electrocardiogram (ECG), which demonstrates the general musicality of the heart and can be checked using non-prominent cathodes on the waist or limbs, has been appeared with prognostic importance for cardiovascular diseases. In this manner, more than 24 h or 48 h strolling ECG looking at is swinging to be progressively indispensable in both homecare and clinical settings to keep away from cardiovascular disease and perceive symptomatic signs for patients with uncommon events. In another point, as the characteristics of ECG signs are exceedingly dependent on the customer's physical status, a mix system to screen ECG and physical development is in unprecedented need. Merging with setting information from development status is profitable to improve investigation exactness on the ECG signals, recognize the most broadly perceived strange ECG outlines in different activities, and evaluate the heart capacities with respect to the clinicians. As a rule, patients need to pass on a huge instrument for relentless ECG checking, which constrains their flexibility and makes them uncomfortable with such an assortment of terminals and connections around their bodies.

With the change of equipment over the traverse recently years, all the more fiscally sharp have been proposed to swap routine systems for convenient ECG viewing. In 2012, Christian et al., showed a framework level low-control remote sensor for entire arrangement biomedical banner viewing. The proposed strategy of an ECG circuits was seemed to incite to 2.5 conditions control sparing. In 2014, a blended banner framework on-chip (SoC) melded essential printed style end (AFE) with DSP back-end was proposed. The remote ECG checking framework joined the proposed SoC and Bluetooth custom can execute a power utilization of 13.34 mW while transmitting ECG development with 256 Hz reviewing rate by strategy for Bluetooth. There are likewise some accommodating business gadgets up 'til now, for example, eMotion from MEGA Electronics Ltd and remote success checking framework from IMEC, them two are furnished with a Bluetooth module. Despite the way that the reported ECG signal gaining circuits are remarkable in planning or power transform, they don't fill in as a finished framework to give a great measure of supportive points of confinement, for example, arrhythmias recognizing verification and setting cautious data, actually, application.

With the change of gadgets over the span of late years, more financially savvy have been proposed to swap customary procedures for portable ECG watching. In 2012, Christian et al., exhibited a framework level low-control remote sensor for whole deal biomedical signal watching. The proposed game plan of

an ECG circuits was appeared to incite to 2.5 circumstances control saving. In 2014, a mixed signal framework on-chip (SoC) consolidated straightforward printed style end (AFE) with DSP back-end was proposed. The remote ECG checking framework incorporated the proposed SoC and Bluetooth tradition can execute a power usage of 13.34 mW while transmitting ECG movement with 256 Hz inspecting rate by method for Bluetooth. There are also some advantageous business contraptions as yet, for instance, eMotion from MEGA Electronics Ltd and remote prosperity checking framework from IMEC, them two are outfitted with a Bluetooth module. Regardless of the way that the reported ECG signal acquiring circuits are remarkable in designing or power change, they don't fill in as a completed framework to give a significant measure of restorative limits, for instance, arrhythmias recognizable proof and setting careful information, in fact, application.

In another point, the no matter how you look at it of mobile phone with successful preparing limit and fast data get to by method for wifi, 3G/4G cell organize, makes the ECG wireless applications open. With high-assurance touch-screen and comprehensive correspondence interfaces, the phone based framework cannot simply show continuous ECG signals sent from the ECG sensor, furthermore transmit it to remote figuring server to give restorative administrations advantage. Likewise, the wireless can be used to see physical development in light of verifiable sensors with high exactness and unflinching quality.

Along these lines, how to misuse open device to decrease the power usage of the ECG checking framework while giving profitable assurance information to the customers is imperative. In this work, we portray a wearable setting careful ECG checking framework contained a self-created joined ECG sensor for constant, whole deal remote ECG watching and a mobile phone for abnormal ECG plans and physical development affirmation. The ECG acquiring sensor realized with a full custom, totally fused and low power AFE is displayed in our review to minimize the size and power use. With Bluetooth development, the picked up ECG signal is sent to customer's mobile phone for steady show and arrhythmias recognizing evidence. Meanwhile, joining with the setting information gave by the certain kinematic sensors (tri-accelerometer, spinner, and alluring sensor) in the mobile phone, this framework can see a customer's physical activities and thusly improve the accuracy for perceiving ECG abnormal cases. Differentiated and past reviews, we give a phase to low-control, whole deal and correct ECG checking with a self-arranged ECG sensor, activity affirmation and after that data mix for improving the assurance exactness with no extra cost on engine sensor layout however with the help of the unlimited mobile phone.

CAPACITIVE SENSING METHOD

Considering the distinctive sorts of ECG distinguishing procedures, for instance, resistive and capacitive identifying systems, the capacitive recognizing methodology, a kind of non-contact distinguishing system, is

wound up being a predominant alternative in giving customer comfort than the standard wet ECG, which uses the resistive recognizing strategy. The capacitive recognizing technique is executed using a metal anode, a defender, and the patient's body, which together edge a capacitor. The body-terminal electrical model involves two ways. The way including the interface potential and the resistor is known as the Nernst way. This kind of identifying procedure is known as the resistive recognizing system and is used in wet ECG, whereby a gel enables trade of charges between the patient's body and the anode.

The other way is known as the capacitive route, in which the trading of charges happens through the capacitive coupled anodes. As demonstrated by the written work, distinctive defenders, for instance, silicon dioxide, fire varnish, anodized aluminum, anodic ensured tantalum oxide or barium titanate have been used as encasings for capacitive coupled terminals because these materials indicate high permittivity. In this review, a cotton texture would be used as opposed to an unyielding material to keep any troubling, affectability, and pain to the customer. Other than being invaluable, the upsides of capacitively coupled ECG identifying are that it can be presented in nearby circumstances that join things, for instance, pieces of clothing, beds, and situates and can be intended to pass on through wires or remotely with family electronic gadgets such a PC, a phone or even screens. In like manner, exact estimation is obtained as the patient won't not realize that his/her key signs are being

recorded. The shortcoming of capacitively coupled ECG distinguishing is that the signal quality is not commensurate to that of wet ECG because of the high impedance of the skin, making the body go about as a gathering mechanical assembly for disturbance. Development old rarities are difficult to discard, as any slight movement of terminals would change the coupling capacitance, in this way impacting the signal quality.

System Architecture

Considering the distinctive sorts of ECG recognizing systems, for instance, resistive and capacitive identifying methods, the capacitive distinguishing technique, a kind of non-contact identifying methodology, is ended up being an unrivaled alternative in giving customer comfort than the conventional wet ECG, which uses the resistive distinguishing procedure. The capacitive recognizing strategy is realized using a metal terminal, an encasing, and the patient's body, which together casing a capacitor. The body-terminal electrical model contains two ways. The way including the interface potential and the resistor is known as the Nernst way. This kind of identifying procedure is known as the resistive recognizing methodology and is used in wet ECG, whereby a gel enables trade of charges between the patient's body and the terminal.

The other way is known as the capacitive path, in which the trading of charges happens through the capacitive coupled terminals. According to the written work, distinctive separators, for instance, silicon dioxide, fire varnish, anodized aluminum, anodic secured

tantalum oxide or barium titanate have been used as encasings for capacitive coupled cathodes in light of the way that these materials indicate high permittivity. In this review, a cotton texture would be used instead of a rigid material to keep any exacerbation, affectability, and bother to the customer. Other than being favorable, the advantages of capacitively coupled ECG distinguishing are that it can be presented in nearby circumstances that consolidate things, for instance, clothing, beds, and situates and can be intended to give through wires or remotely with family unit electronic gadgets such a PC, a phone or even screens. Moreover, exact estimation is procured as the patient won't not realize that his/her principal signs are being recorded. The burden of capacitively coupled ECG identifying is that the signal quality is not equivalent to that of wet ECG in light of the high impedance of the skin, making the body go about as a gathering mechanical assembly for hullabaloo. Development old rarities are difficult to wipe out, as any slight evacuation of cathodes would change the coupling capacitance, along these lines affecting the signal quality.

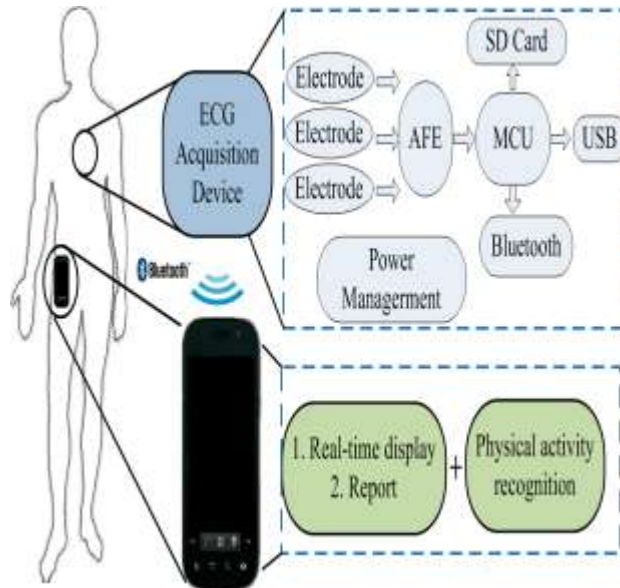

Figure 1: Schematic diagram of proposed context-aware electrocardiogram (ECG) monitoring system.

The positive square blueprint of the proposed AFE. Set up of an alternate easy to-cutting edge change over module, the characteristic easy to-mechanized work in the MCU module was used as a part of the proposed framework to improve capability. Remembering the ultimate objective to decide the trial of tradeoff among size and transmission limit of the circuit, we plot a full DA module with high pass work using pseudo-resistor development and a moment low pass Gm-C channel, instead of standard instrumentation enhancer and Sallen-Key or Nyquist low pass channel. The delineated module can comprehend a low pass band on the chip. Meanwhile, the DA module using the capacitance strengthening structure can similarly shed the DC adjust voltage of anodes which limit the get of the primary stage enhancer. Besides, as an aftereffect of the corresponding resistance of human body, united with the decide that proportionate data

resistance of the AFE should be greater than $10\text{ M}\omega$ to get rid of the effect of voltage divider, we require a data support to get an adequately high information resistance and pull back the anode from strengthening stage if there ought to emerge an event of some other common obstacle parts. An inactive high pass channel is proposed to ensure the DC working voltage with a cutoff repeat of 0.5 Hz . A moment low pass Gm-C channel is joined and took after by an additional opening up stage to get a higher get. We fuse a standard right-leg driven circuit to upgrade the consistent mode expulsion extent (CMRR) execution. Remembering the true objective to comprehend the partition among cathode and human skin for a wearable, pleasant contraption for whole deal watching, we arrange an open circuit with relative resistance greater than $10\text{ M}\omega$. Besides, a snappy restore work circuit is facilitated to help AFE come back to working state brisk from unusual state. A power organization module is planned to give an unfaltering working voltage and current.

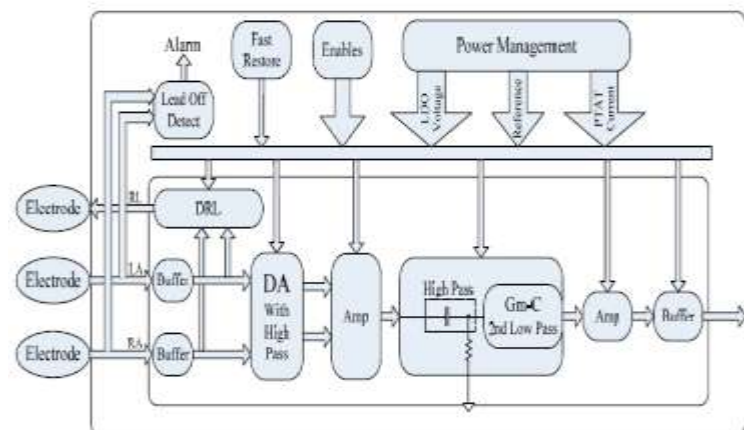

Figure 3: Block diagram of the analog front-end (AFE).

Physical Activity Recognition with Built-in Kinetic Sensors in the Smartphone

As presented above, mobile phone can be used to distinguish the fall state and see physical activities with a level of exactness comparable to that of the tri-crucial accelerometer. In our past review, we utilized a mobile phone to see 5-sort physical development with three innate kinematic sensors (tri-accelerometer, spinner, and appealing sensor), including static, walking, running, going upstairs and going first floor. The examination occurs on 8097 development data have demonstrated the proposed approach can comprehend an abnormal state of accuracy with affirmation rate of 89.6%. The think also surveyed the impact of different pockets and presentations for development affirmation, the trial comes to fruition displayed that the proposed game plan is coldblooded to four presentations including head upward and go up against inside, head upward and face outward, head diving and stand up to inward, head diving and face outward. For the six unmistakable pockets, from the results in the components from pant pockets are with higher vacillation differentiated and coat pockets, as more noteworthy accelerating is made from the lower extremities than that from the capacity compartment part while the subject is moving.

What's more, the components from different pants pockets are near. We moreover evaluated the standard derivation of the mean accelerating data among the three activities including rest, walking and running for each pocket presented in the results showed that the standard findings are 4.87 (with mean

enlivening data of 0.85 for rest, 3.24 for walking and 10.22 for running) and 5.06 (with mean expanding speed data of 0.72 for rest, 3.41 for walking and 10.53 for running) for ideal back pants pocket and right front pants stash freely, while 3.50 for left coat take (with mean stimulating data of 1.08 for rest, 3.51 for walking and 7.99 for running). In another word, the expanding speed data from pants pockets are with higher detachment than coat stash. As needs be, the relative game plan will be used as a piece of this review to see ordinary sorts of physical status that have basic effect on the ECG configuration, including rest, walking and running, with the mobile phone in any pants pockets.

The running and walking status was perceived in light of the ambulation speed, which was portrayed. As requirements be, the speed underneath 84 m/min is described as walking, else it is separate as running. As the innate accelerometer, spinner, and the presentation sensor of a PDA which reflected expanding speed, saucy speed, and presentation of physical activity were used to accumulate the information for request. Remembering the ultimate objective to reduce the effect of estimation fuss, we used a low-pass channel with 10 Hz cutoff repeat to pre-handle the data going before the development gathering. Besides, sliding window approach was used to reduce the slant rose up out of sensor sensibility and hullabaloo by dividing the signs into different minimal secured windows. At a testing repeat of 25 Hz, each window with half cover addresses 1.6 s. Five signs, including the signal sizes of the

accelerometer and whirligig sensor, the X, Y, Z heading estimation of the alluring sensor, were assembled for each example. By then 30 highlights (mean, standard deviation, center, skewness, Kurtosis, Inter-quartile-extent of the five signs for each window) were isolated for course of action. After that, we organized activities (rest, walking and running) from step by step life data using decision trees in WEKA environment using the isolated 30 highlights.

The decision tree was made using the J48 figuring, an open source Java utilization of the C4.5 decision tree computation in the WEKA gadget. It is executed in the going

with highways: (1) At each center of the tree, the property that parts the dataset into subsets accumulated in one class or the other most effectively, that is, with the most raised institutionalized information get, is settled on a decision; (2) To keep up a vital separation from the over-fitting issue, a quit part run is required to control the advancement of the tree. In our review, the quit part choose was described that the base number of articles at each terminal center point should be greater than 30. The J48 is completed on the preface that if a more diminutive tree structure is with comparative execution to a greater one, the humbler one would be picked.



Figure 4. The block diagram of the physical activity recognition scheme

CAPACITIVE COUPLED ECG SENSINGSYSTEM:

The proposed ECG framework configuration has three cathodes, two of which will be determined to the subject's midriff for bio-signal get while the third terminal will be used as a wellspring of point of view anode and will be determined to the subject's hip or

some other part of the body. The reference cathode would in like manner be used to reduce standard mode noise. A RBIAS is set between each terminal and the pad enhancer and ought to work as a discharger of DC and of any electrostatic charge made by the cotton texture to ground. High data impedance supports are related between the

cathodes and the instrumentation speaker with a particular true objective to facilitate the high impedance of the skin. The biosignal gained from the anodes is opened up, isolated, and filtered by the instrumentation intensifier. The upgraded isolated signal is then adhered to a low pass procedure (LPF), a high pass channel (HPF), and a 60 Hz step channel to wipe out the undesirable repeat parts from the signal. An oscilloscope is then used to demonstrate the straightforward front-end of the yield signal. Our ECG framework included two versatile copper terminals for biosignal get and a reference anode for typical mode debilitating. LMC6001 was picked among various ICs as a bolster intensifier as an aftereffect of its high data impedance. The biosignal snatched by these terminals was heightened, isolated, and filtered by

INA116. Since the consistent mode uproar is a significant wellspring of clutter in capacitive ECG, INA116 was chosen for the framework in light of its high fundamental mode rejection extent, low voltage buoys, and low disturbance. The opened up isolated signal was then adhered to a low pass procedure with a corner repeat of 795.8 Hz, a high pass channel with a corner repeat of 0.8 Hz, and a 60 Hz step channel to wipe out the undesirable repeat parts from the signal to get an ECG signal extent of 0.1 Hz to 100 Hz. A TDS 2024B modernized stockpiling oscilloscope was used to exhibit the yield signal. To control up the framework, +3.3 and - 3.3 slants were given to the supply of the intensifiers with a particular true objective to diminish the power use of the entire framework.

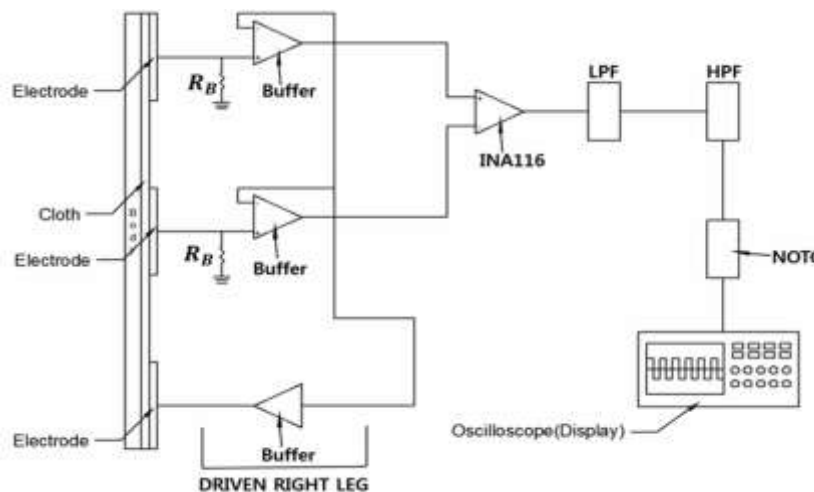

Figure5: Block diagram of the ECG sensor system design.

Results:

Performance of the Proposed Context-Aware ECG Monitoring System

The ECG signal is expanded and filtered by the chip of AFE module, then the straightforward signal from AFE is changed

over to automated movement in MCU module. After took care of with wavelet planning computation and highlight extraction examination counts, the delivered electronic signal are recorded in the memory cells or transmitted to the individual phone for data mix and examination. Right when the watching method completed, the components of subjects' acquired ECG signal were expelled using WABS procedure and MLE system and as demonstrated by these components a brief report expecting to perceive 10-sort arrhythmias and HRV examination. The

demonstrative limit was furthermore affirmed using the multi-parameter test framework (MEDSIM 300B). The testbed in which the multi-parameter test framework was used to create ECG signals with different arrhythmias sorts. We surveyed the partition limit of in regards to half aggregate blunder rat2 (HTER), which reciprocals to $(\text{false affirmation rate (FAR)} + \text{false expulsion rate (FRR)})/2$. The particular report is represented, from the item on phone can comprehend a not too bad isolation execution in seeing abnormal case with high dependability.



Figure 6: (a) abnormal ECG signal; (b) the brief report

A case for reliably watching one subject's setting careful ECG with the proposed framework is shown. The review separate the subject is with a heart rate of 56 while resting. Right when the subject changed his activity status from walking around running, there was a sharp addition in heart rate of the subject from 67 to 120. By then, in the wake of running, the subject rested 30 s with a heart rate of 91. Right when the subject

was resting 300 s consequent to running, heart rate of the subject recovered to the regard before running. From the above report we can see, the setting careful framework is essential to survey the customer's real prosperity condition. For example, a heart rate of 120 is for the most part regarded as tachycardia from master involvement. Regardless, it is attractive if the customer is running or taking movement,

which can be reflected from the activity affirmation course of action. Besides, seeing on the assortment of ECG with the physical development gives a significant gadget to evaluate one's heart work on the adaptation to the change of status.

To demonstrate the benefit of setting careful ECG to see physical development while checking ECG, we in like manner played out an authentic examination on the change on the assurance accuracy merged with physical activity. Table 11 gives the odd illustrations perceived already, then sometime later joined with setting information and the examination with the genuine cases from the clinician's investigation.

The general heartbeat number is 7100. VT is as often as possible designated no less than three throbs on an ECG that are at a rate of more than 100 bangs for each minute in static status, in any case, when trading from walking status to running status, the heart rate extended rapidly, perhaps in an extent of 120–180. Henceforth, VT can be portrayed as no less than three beats are with a rate of more than 180 beats for every minute in running status, as the volunteers

are around 24 years old. Remembering the ultimate objective to demonstrate the partition execution of the proposed setting careful ECG framework, beside a whiz. The think also considered the HTER between the single ECG sensor and the setting careful ECG framework on seeing odd illustrations. From the detachment limit was improved in a particular degree by blend of physical development with a HTER of 2.6%, stood out and 2.8% from the single ECG sensor, and thusly displayed the suitability of the proposed setting careful ECG framework, in fact, application. Besides, the proposed framework can recognize the most unremitting bizarre ECG plans in different activities for each subject, and as requirements be, we can give pleasing proposals to him to be wary in the midst of this kind of activity. For example, as our examination is done on strong subjects, the unpredictable illustrations have a low rate; regardless, we moreover found that most bizarre cases are occurring at running status. In another words, a lot of asymptomatic ECG illustrations can be recognized through watching setting careful ECG.



Figure 7: a) the subject rested 30 s after running; (b) the subject rested 90 s after running; (c) the subject rested 300 s after running.

Table 1: Statistical analysis on the performance of proposed context-aware ECG system.

Abnormal Patterns	Detected from ECG Sensor	Detected from Context-Aware ECG	Sensor Actual
Bigeminy	0	0	0
Trigeminy	0	0	0
Sinus arrhythmia	0	0	0
Missed beat	0	0	0
Ventricular premature beats	4	4 (3 in running, 1 in walking)	4
Atrial premature beats	5	5 (3 in running, 1 in walking, 1 in rest)	5
Interpolated ventricular premature beat	0	0	0
Ventricular tachycardia	31	9 (8 in running, 1 in walking)	10
Pause Beat	0	0	0
Tachycardia	6	0	0

Table 2. Discrimination ability comparison between the proposed context-aware ECG system and single ECG sensor. TP: true positive, FN: false negative, TN: true negative, FP: false positive.

	ECG Beat Number				Discrimination Ability (HTER)
	TP	FN	TN	FP	
Single ECG Sensor	18	1	7054	27	2.8%
Context-Aware ECG System	18	1	7081	0	2.6%

A wearable setting careful ECG checking framework, which is incorporated a self-delineated totally planned low-control ECG watching sensor and three innate kinematic sensors of the PDA for physical development affirmation and subsequently arrhythmias

acknowledgment, is presented in this paper. In the proposed framework, a wearable ECG acquisition sensor with a total power dispersal of 12.5 mW is made, and the whole sensor is little with a size of 58 × 50 × 10 mm for wearable watching application. From

the trial happens, the showed AFE and securing contraption can offer comparable execution to standard device on measuring ECG movement with less power use. Joined with the verifiable element sensors of the phone, the framework can see customer's physical development with high exactness and in this way evaluates the veritable status which uncommon cases of ECG.

The test comes to fruition have moreover demonstrated its achievability in upgrading exactness for the finish of arrhythmias. The proposed wearable and power-beneficial ECG checking framework is possessed all the necessary qualities for helpful applications and will serve as a patient-obliging alternative decision for reliable ECG watching. We expect it will wind up being a more profitable stage for additional data blend and examination. Regardless, the exploratory data is still little with seven strong subjects and three activities included. Later on, we will focus on a comprehensive review on the impact of more activity sorts and human attempts on ECG signals from incalculable in light of the proposed framework. What's more, an upgraded ECG watching framework will be further improved with not simply more diminutive size, cut down weight, cut down power use and higher CMRR, furthermore subsequently recognizing the unpredictable cases in the midst of step by step works out.

Conclusion:

In the proposed framework, an Android application was likewise made to accomplish a portable human services framework. The proposed application can demonstrate an ECG motion continuously on a diagram and

afterward dissect the information to settle on shrewd choices. The proposed calculation was tried on a PC to approve the framework. The outcomes demonstrate that the proposed heart rate computation mistake rate is under 10% contrasted and a standard framework. Furthermore, beside building a good electronic circuit board for ECG signal taking care of, another zone one must consider with as a non-contact ECG is the anode skin interface. To obtain incredible signal quality, the terminal contact locale, the encasing dielectric relentless, the separator thickness, and the conductivity of the anode ought to be considered. Development trinkets, regardless, remains an authentic test in adaptable and wearable ECG frameworks since they are portrayed in the written work and are obligated to human transportability, not in the least like diverse parameters, for instance, get, power, racket, thus on that can be adequately reproduced and measured. Regardless of the way that the present contraption is adaptable and consumes less power, it is not as meager as needed. Along these lines, our future work will concentrate on fulfilling somewhat estimate remote ECG sensor framework for constant vital sign checking.

REFERENCE:

- [1] Wang, L.D.; Kong, L.Z.; Wu, F.; Bai, Y.M.; Burton, R. Chronic Diseases 4—Preventing Chronic
- [2] Diseases in China. *Lancet* **2005**, *366*, 1821–1824.
- [3] Katritsis, D.G.; Siontis, G.C.M.; Camm, A.J. Prognostic Significance of Ambulatory ECG Monitoring for

- Ventricular Arrhythmias. *Prog. Cardiovasc. Dis.* **2013**, *56*, 133–142.
- [4] Jabaudon, D.; Sztajzel, J.; Sievert, K.; Landis, T.; Sztajzel, R. Usefulness of Ambulatory 7-day ECG Monitoring for the Detection of Atrial Fibrillation and Flutter after Acute Stroke and Transient Ischemic Attack. *Stroke* **2004**, *35*, 1647–1651.
- [5] Fong, E.M.; Chung, W.Y. Mobile Cloud-Computing-Based Healthcare Service by Noncontact ECG Monitoring. *Sensors* **2013**, *13*, 16451–16473.
- [6] Poon, C.C.Y.; Zhang, Y.T. Perspectives on High Technologies for Low-Cost Healthcare—The Chinese Scenario. *IEEE Eng. Med. Biol. Mag.* **2008**, *27*, 42–47.
- [7] Park, S.; Jayaraman, S. Enhancing the Quality of Life Through Wearable Technology. *IEEE Eng. Med. Biol. Mag.* **2003**, *22*, 41–48.
- [8] Nemati, E.; Deen, M.J.; Mondal, T. A Wireless Wearable ECG Sensor for Long-Term Applications. *IEEE Commun. Mag.* **2012**, *50*, 36–43.
- [9] Kim, H.; Kim, S.; van Helleputte, N.; Artes, A.; Konijnenburg, M.; Huisken, J.; van Hoof, C.; Yazicioglu, R.F. A Configurable and Low-Power Mixed Signal SoC for Portable ECG Monitoring Applications. *IEEE Trans. Biomed. Circuit Syst.* **2014**, *8*, 257–267.
- [10] Bachmann, C.; Ashouei, M.; Pop, V.; Vidojkovic, M.; Groot, H.D.; Gyselinckx, B. Low-Power Wireless Sensor Nodes for Ubiquitous Long-Term Biomedical Signal Monitoring. *IEEE Commun. Mag.* **2012**, *50*, 20–27.
- [11] E Motion ECG. Available online: <http://www.megaemg.com/products/e-motion-ecg/> (accessed on 3 September 2013).
- [12] Depari, A.; Flammini, A.; Sisinni, E.; Vezzoli, A. A Wearable Smartphone-Based System for
- [13] Electrocardiogram Acquisition. In Proceedings of the 2014 IEEE International Symposium on
- [14] Medical Measurements and Applications (MeMeA), Lisboa, Portugal, 11–12 June 2014; pp. 1–6.
- [15] Szczepański, A.; Saeed, K. A Mobile Device System for Early Warning of ECG Anomalies. *Sensors* **2014**, *14*, 11031–11044.
- [16] Arif, M.; Bilal, M.; Kattan, A.; Ahamed, S.I. Better Physical Activity Classification Using Smartphone Acceleration Sensor. *J. Med. Syst.* **2014**, *38*, 1–10.