

# Web Based Industrial Parameters Monitoring System through WSN and Arm7 with Voice Alerting

<sup>1</sup>vuda Pridhvi Raj & <sup>2</sup>K. Sangeeth Kumar

<sup>1</sup>Pg Scholar, Department of ECE, Kakinada Institute Of Engineering And Technology, Yanam Road,, Matlapalem, Talarevu Mandal, Corangi, Andhra Pradesh 533461. [pridhviraj511@gmail.com](mailto:pridhviraj511@gmail.com)

<sup>2</sup> Assistant Professor, Department of ECE, Kakinada Institute Of Engineering And Technology, Yanam Road,, Matlapalem, Talarevu Mandal, Corangi, Andhra Pradesh 533461. [sagneet.mtec@gmail.com](mailto:sagneet.mtec@gmail.com)

**Abstract**— *This paper presents the development of an embedded system that continuously observes the environmental conditions in indoor spaces at distant places. The communication between the system's components is performed using the existent wireless infrastructure based on the IEEE 802.15 standard. The resulted solution provides the possibility of logging measurements from locations all over the world and of visualizing and analyzing the gathered data from any device connected to the Internet. This work encompasses the complete solution, an embedded system, consisting of sensors and the communication protocol, and reaching data management and storage at the cyber level. The experimental results show that the proposed system represents a viable and straight forward solution for environmental and ambient monitoring applications.*

**Index Terms**—Physical parameters, IEEE 802.15 standards, Internet of Things (IoT)

## I. INTRODUCTION

The importance of environmental monitoring is undoubted in our age. This is the field where wireless sensor networks (WSNs) have been first used, their primary purpose consisting in the observation of the physical world and the recording of physical quantities characterizing it. WSNs are large networks of resource-constrained sensors with processing and wireless communication capabilities, which implement different application objectives within a specific sensing field. They can also be used for ambient monitoring, a topic of great interest nowadays as well, indoor air quality representing an important factor affecting the comfort, health, and safety of building occupants. These newly appeared systems have a lot of similarities with the Internet of Things (IoT), an enabler of ubiquitous sensing, that envisions a world in which many

billions of Internet-connected objects or things, with sensing, communication, computing, and potentially actuating capabilities, will coexist, allowing an uninterrupted connection between people and things. This paper presents a system for environmental and ambient parameter monitoring using low-power wireless sensors connected to the Internet, which send their measurements to a central server using the IEEE 802.15 standards. Finally, data from all over the world, stored on the base station, can be remotely visualized from every device connected to the Internet. This overcomes the problem of system integration and interoperability, providing a well-defined architecture that simplifies the transmission of data from sensors with different measurement capabilities and increases supervisory efficiency.

## II. LITERATURE SURVEY

The literature contains a large number of efforts for developing monitoring solutions that benefit from the advantages provided by wireless sensing technology. Reference [13] presents an automated irrigation system based on a distributed wireless network of soil moisture and temperature sensors that achieves water savings of 90% compared with traditional implementations. Sentinella is a smart monitoring solution for the assessment of possible causes of power inefficiency at the photovoltaic panel level based on WSNs [14]. The employment of WSNs in smart grid applications and electrical energy monitoring solutions for large buildings was also investigated [15], [16]. A series of industrial WSNs achieving the acquisition of heterogeneous sensor signals, higher sampling rates, and higher reliability levels has been developed as well [17], [18]. However, most of the proposed solutions are based on the IEEE 802.15.4 standard and ZigBee applications, and they rely on gateways when the data has to be sent to the Internet [13], [16]–[18]. Furthermore, in this case, additional applications have to be developed for encapsulating the data in Internet protocols, such as user datagram protocol (UDP) or transmission control protocol (TCP). Another promising technology providing high power efficiency is Bluetooth Low Energy (BLE), which was first introduced in 2010 with the goal of expanding the use of Bluetooth to power-constrained devices such as wireless sensors [19]. However, a lot of research work still has to be performed in this direction, for finally being able to receive relevant information from remote BLE-enabled devices requiring small amounts of data communication and energy. Furthermore,

gateways are also required for sending the data to the Internet. Therefore, the use of Wi-Fi sensors, as the ones in the system presented in this paper, which connect directly to the existing IEEE 802.11 b/g infrastructure seems to be a better, more straightforward, and less expensive solution. This is beneficial especially for applications deployed in indoor spaces or urban areas, where there is a high probability that access points are present.

## III. PROPOSED SYSTEM

The implementation of proposed system involves mainly two sections, first one is wireless sensor network and second one is central and alerting station.

### A. WIRELESS SENSOR NETWORK

This section contains sensors, 8052, Zigbee and motors. Five sensors are used to monitor the environmental conditions of the atmosphere. The sensors are, Fire sensor, Smoke sensor, Pressure Sensor, Humidity, LDR. It also comprises of Zigbee technology for data transfer to the central station. The wireless sensor network also contains motors for automatic controlling of the physical parameters like temperature, pressure etc.

#### i. FIRE SENSOR

This sensor is used to detect the occurrence of the fire. If there is any fire occurrence in the premises then this sensor will be actuated and transfers the data to the analog to digital converter for processing.

#### ii. SMOKE SENSOR

This sensor is used to detect the occurrence of the smoke. If there is any smoke occurrence in the premises then this sensor will be actuated and transfers the data to the analog to digital converter for processing.

**iii. PRESSURE SENSOR**

This sensor is used to detect the level of the pressure in the pipes. If there are any abnormal changes in the pressure of the pipe then this sensor will detect that changes, transfers the data to the analog to digital converter for processing.

**iv. HUMIDITY SENSOR**

This sensor is used to detect the percentage of the humidity present in the air. If there is high rate of humidity then this sensor will detect the changes in the humidity, and transfers the data to the analog to digital converter for processing.

**v. LDR SENSOR**

This sensor is used to detect the intensity of the light. If the intensity of the light is decreasing then this sensor will detect that changes, and transfers the data to the analog to digital converter for processing.

If any of the sensor got activated then the corresponding motor will rotate to control the situation. By this way automation can be

performed. The changes in the sensor data will be transferred to the central station through Zigbee protocol.

**B. CENTRAL STATION**

This section consists of the ARM7, Zigbee module, Bluetooth module, and voice output module. The Zigbee module will receive the data from the wireless sensor network. This data will be transferred to the Internet through Bluetooth and an application installed in the mobile. If the sensor data is more than the threshold value then the voice module will generate corresponding voice output. By this way we can alert the people who are working under such conditions and we can monitor the changes in the sensor data at any time and at any place by just logging in to the web server called ThingSpeak. This web will store the results of the sensors. So that we can analyze the data at any instant of time.

**IV. BLOCK DIAGRAM**

The below figure shows the block diagram of the Wireless sensor network

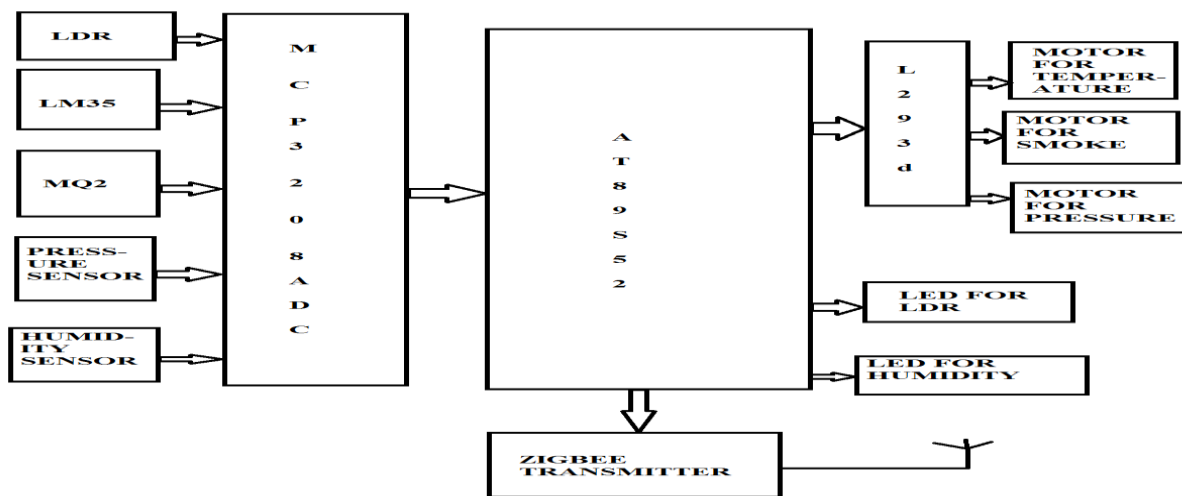

Fig 1: Block diagram of the WSN

**i. FIRE SENSOR**

The LM35 series are precision integrated-circuit temperature sensors, whose output voltage is linearly proportional to the Celsius (Centigrade) temperature. The LM35 thus has an advantage over linear temperature sensors calibrated in ° Kelvin, as the user is not required to subtract a large constant voltage from its output to obtain convenient Centi-grade scaling. The LM35 does not require any external calibration or trimming to provide typical accuracies of  $\pm 1/4^{\circ}\text{C}$  at room temperature and  $\pm 3/4^{\circ}\text{C}$  over a full  $-55$  to  $+150^{\circ}\text{C}$  temperature range.

**ii. SMOKE SENSOR**

A **smoke detector** is a device that detects smoke and issues an alarm. Smoke detectors alert people within hearing range; some also interface with a security system or notify emergency services. An Ionization Smoke Detector has two key parts: the ionization chamber, and a source of radiation.

**iii. PRESSURE SENSOR**

This sensor is used to detect the level of the pressure in the pipes. If there are any abnormal changes in the pressure of the pipe then this sensor will detect that changes, transfers the data to the analog to digital converter for processing.

**iv. HUMIDITY SENSOR**

Humidity sensors are gaining more significance in diverse areas of measurement and Control technology. Manufacturers are not only improving the accuracy and long-term drift of their sensors, they are improving their durability for use in different environments, and simultaneously reducing the component size and the price.

**v. LDR SENSOR**

A photo resistor or Light Dependent Resistor or CdS (Cadmium Sulphide) Cell is a resistor whose resistance decreases with increasing incident light intensity. It can also be referred to as a photoconductor.

The below diagram shows the central station.

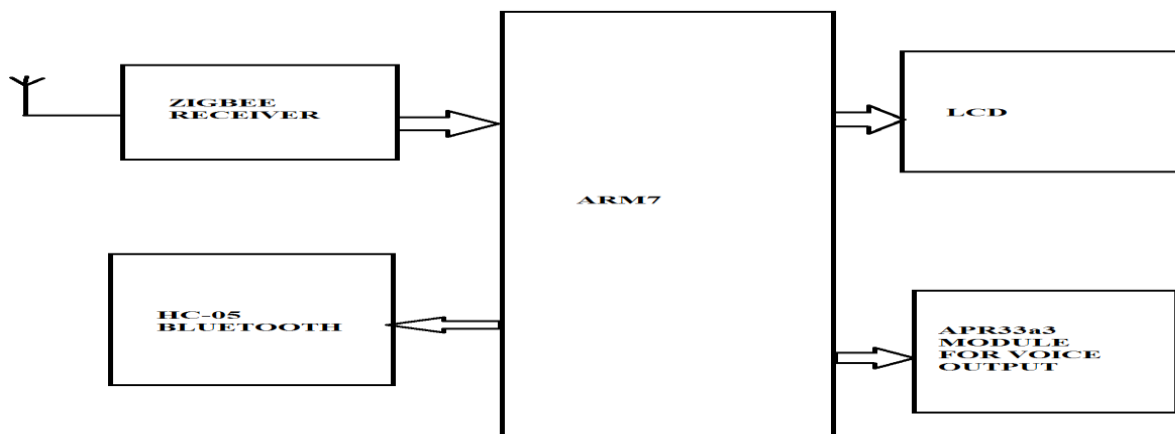

Fig 2: central station

**i. ZIGBEE**

ZigBee is the name of a specification for a suite of high level communication protocols using small, low-power digital radios based on the IEEE 802.15.4-2006 standard for wireless personal area networks (WPANs), such as wireless headphones connecting with cell phones via short-range radio. The technology is intended to be simpler and cheaper than other WPANs, such as Bluetooth. ZigBee is targeted at radio-frequency (RF) applications that require a low data rate, long battery life, and secure networking.

**ii. BLUETOOTH**

Bluetooth is a wireless protocol utilizing short-range communications technology facilitating data transmission over short distances from fixed and/or mobile devices, creating wireless personal

area networks (PANs). The intent behind the development of Bluetooth was the creation of a single digital wireless protocol, capable of connecting multiple devices and overcoming issues arising from synchronization of these devices.

**iii. APR33a3 MODULE**

The APR33A series are powerful audio processor along with high performance audio analog-to-digital converters (ADCs) and digital-to-analog converters (DACs). The aPR33A series are a fully integrated solution offering high performance and unparalleled integration with analog input, digital processing and analog output functionality. The aPR33A series incorporates all the functionality required to perform demanding audio/voice applications.

**V. RESULTS**

The various results observed are shown below.

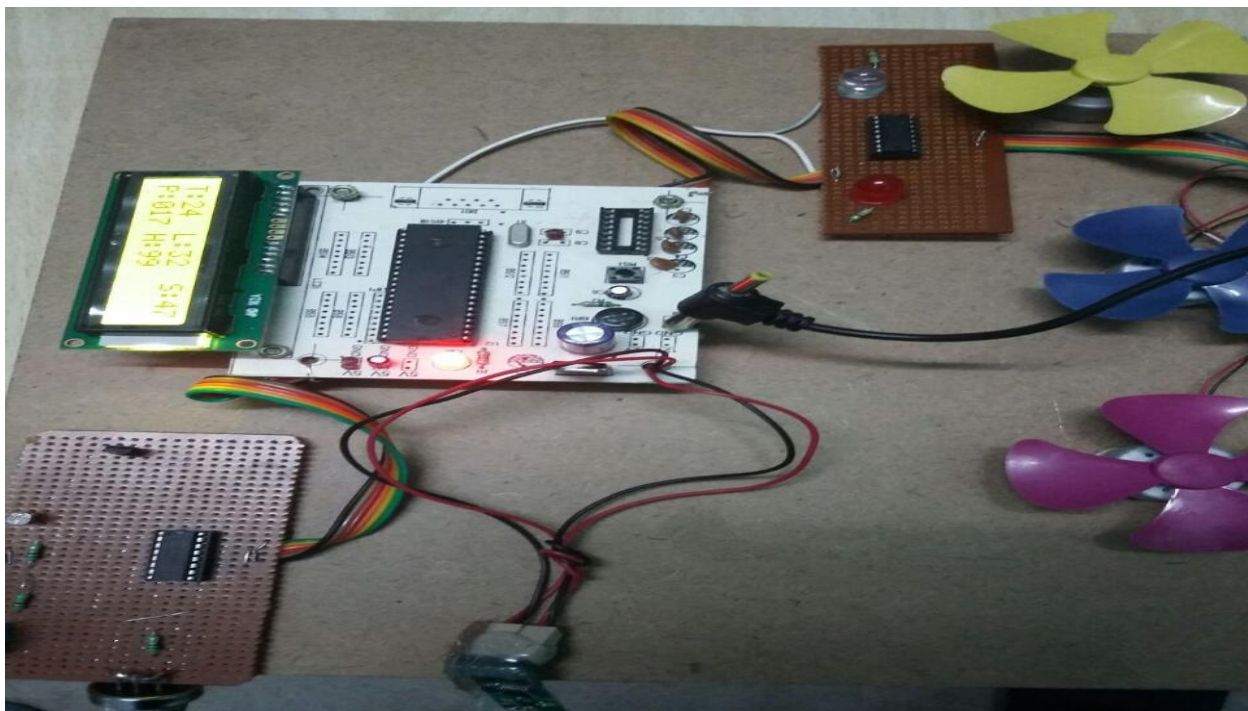

Fig 3: WSN system

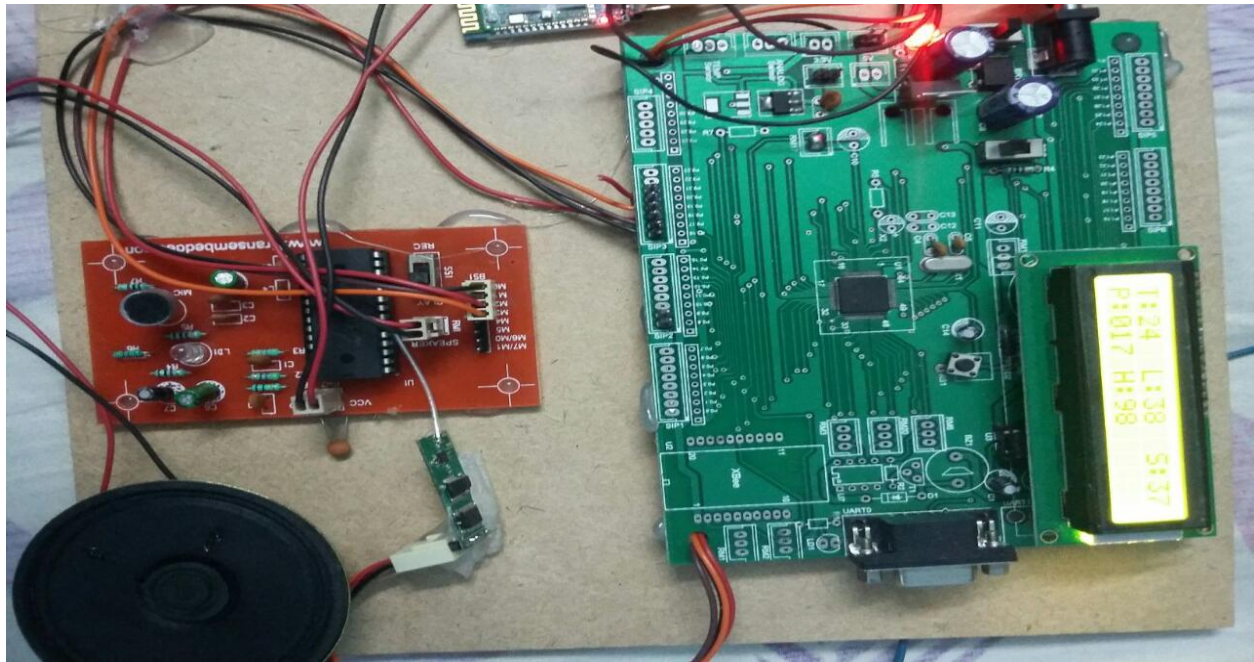

Fig 4: central station



Fig 5: monitoring in android application installed in mobile

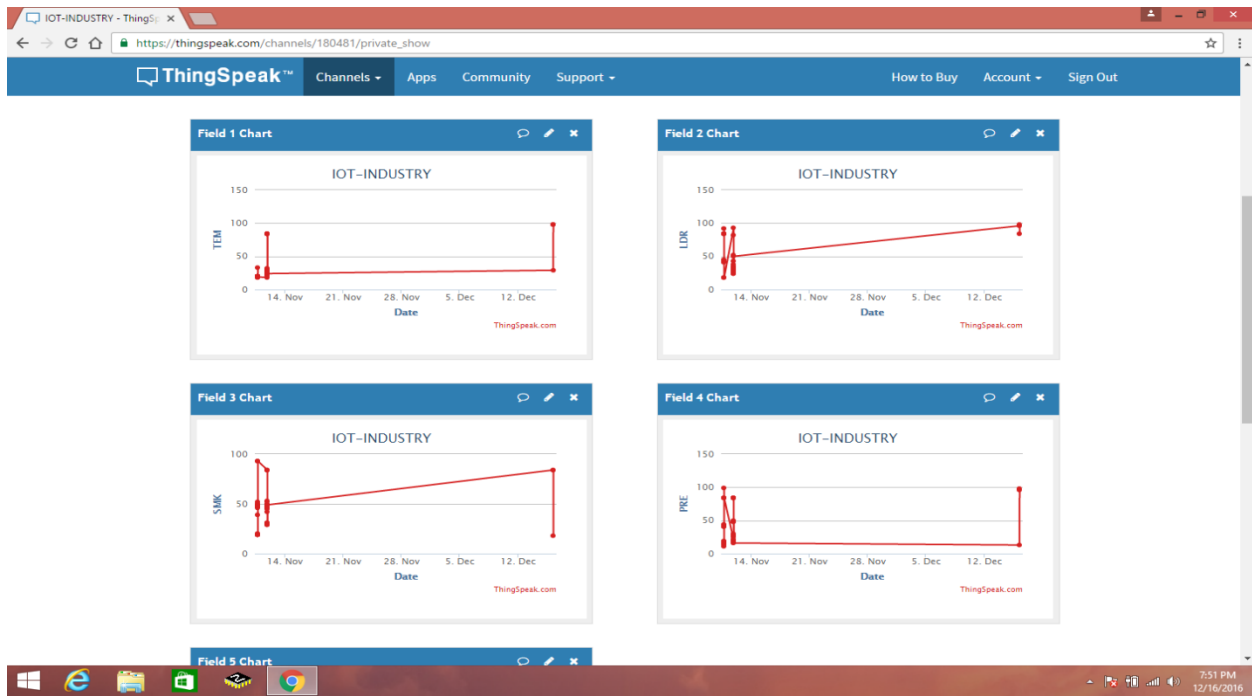

Fig 6: results monitored in the web page

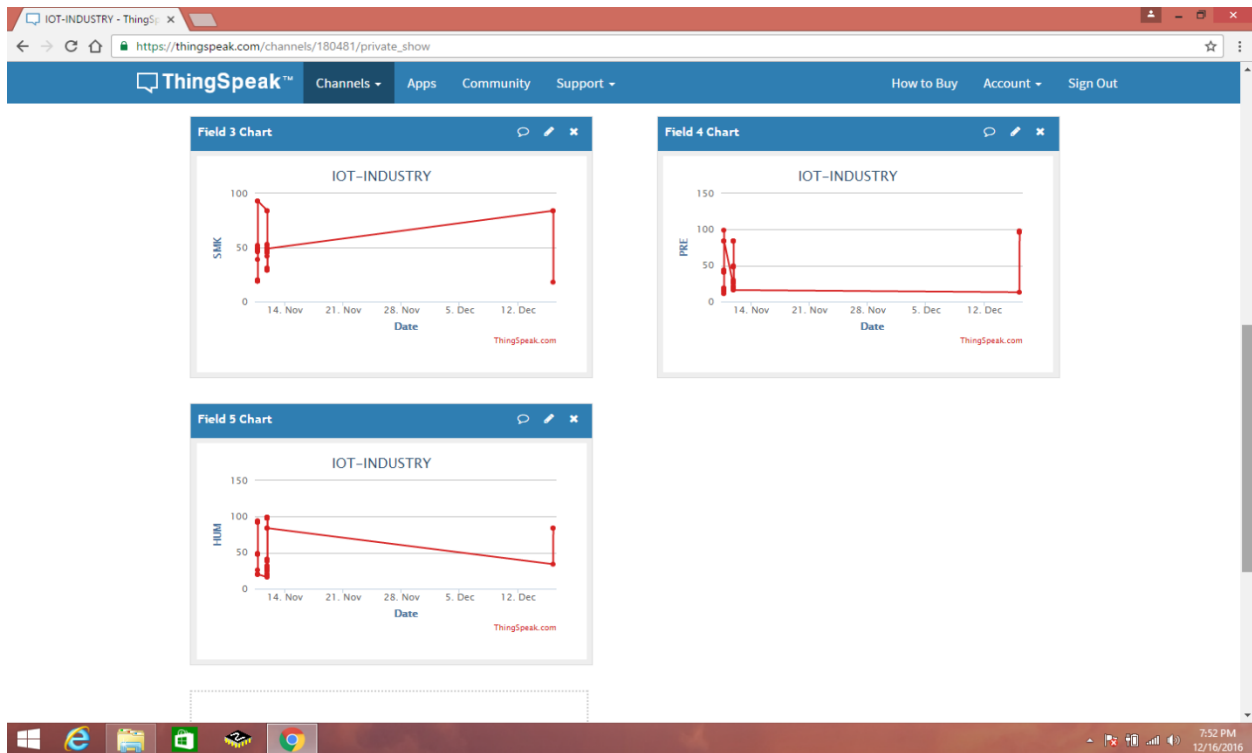

Fig 7: results monitored in the web page

## VI. CONCLUSION

The development of an embedded system which monitors environmental parameters based on the existent IEEE 802.15 and IoT infrastructure was presented. It employs sensors measuring the ambient or the environment, which send messages to an IoT platform using UDP. The communication protocol and the design of the nodes help in achieving low power consumption, offering battery lifetimes of several years. The system eliminates bulky solutions, provides the possibility of logging data where Wi-Fi network coverage exists, and can be used in a wide range of monitoring applications.

## VII. FUTURE ENHANCEMENT

Future work intends to enhance the reliability and security of the proposed system with live video monitoring etc can be implemented.

## REFERENCES

- [1] D. F. Larios, J. Barbancho, G. Rodríguez, J. L. Sevillano, F. J. Molina, and C. León, "Energy efficient wireless sensor network communications based on computational intelligent data fusion for environmental monitoring," *IET Commun.*, vol. 6, no. 14, pp. 2189–2197, Sep. 2012.
- [2] J.-Y. Kim, C.-H. Chu, and S.-M. Shin, "ISSAQ: An integrated sensing systems for real-time indoor air quality monitoring," *IEEE Sensors J.*, vol. 14, no. 12, pp. 4230–4244, Dec. 2014.
- [3] L. Zhang and F. Tian, "Performance study of multilayer perceptrons in a low-cost electronic nose," *IEEE Trans. Instrum. Meas.*, vol. 63, no. 7, pp. 1670–1679, Jul. 2014.
- [4] S. Sharma, V. N. Mishra, R. Dwivedi, and R. R. Das, "Quantification of individual gases/odors using dynamic responses of gas sensor array with ASM feature technique," *IEEE Sensors J.*, vol. 14, no. 4, pp. 1006–1011, Apr. 2014.
- [5] J. Wan, M. Chen, F. Xia, D. Li, and K. Zhou, "From machine-to-machine communications towards cyber-physical systems," *Comput. Sci. Inf. Syst.*, vol. 10, no. 3, pp. 1105–1128, 2013.
- [6] M. Broy, M. V. Cengarle, and E. Geisberger, "Cyber-physical systems: Imminent challenges," in *Large-Scale Complex IT Systems. Development, Operation and Management (Lecture Notes in Computer Science)*, vol. 7539, R. Calinescu and D. Garlan, Eds. Heidelberg, Germany: Springer, 2012, pp. 1–28.
- [7] F.-J. Wu, Y.-F. Kao, and Y.-C. Tseng, "From wireless sensor networks towards cyber physical systems," *Pervasive Mobile Comput.*, vol. 7, no. 4, pp. 397–413, 2011.
- [8] S. Gao et al., "A cross-domain recommendation model for cyberphysical systems," *IEEE Trans. Emerg. Topics Comput.*, vol. 1, no. 2, pp. 384–393, Dec. 2013.
- [9] A. Zaslavsky. (Sep. 2013). Internet of Things and Ubiquitous Sensing. [Online]. Available: <http://www.computer.org/portal/web/computingnow/archive/september2013>, accessed Sep. 2014.
- [10] Z. Guo, P. Chen, H. Zhang, M. Jiang, and C. Li, "IMA: An integrated monitoring architecture with sensor networks," *IEEE Trans. Instrum. Meas.*, vol. 61, no. 5, pp. 1287–1295, May 2012.



- [11] S. Tozlu, M. Senel, W. Mao, and A. Keshavarzian, "Wi-Fi enabled sensors for Internet of Things: A practical approach," *IEEE Commun. Mag.*, vol. 50, no. 6, pp. 134–143, Jun. 2012.
- [12] A. Berger, M. Pichler, J. Klinglmayr, A. Potsch, and A. Springer, "Low-complex synchronization algorithms for embedded wireless sensor networks," *IEEE Trans. Instrum. Meas.*, vol. 64, no. 4, pp. 1032–1042, Apr. 2015.
- [13] J. Gutierrez, J. F. Villa-Medina, A. Nieto-Garibay, and M. Porta-Gandara, "Automated irrigation system using a wireless sensor network and GPRS module," *IEEE Trans. Instrum. Meas.*, vol. 63, no. 1, pp. 166–176, Jan. 2014.
- [14] B. Ando, S. Baglio, A. Pistorio, G. M. Tina, and C. Ventura, "Sentinella: Smart monitoring of photovoltaic systems at panel level," *IEEE Trans. Instrum. Meas.*, vol. 64, no. 8, pp. 2188–2199, Aug. 2015.
- [15] G. Tuna, V. C. Gungor, and K. Gulez, "Wireless sensor networks for smart grid applications: A case study on link reliability and node lifetime evaluations in power distribution systems," *Int. J. Distrib. Sensor Netw.*, vol. 2013, Jan. 2013, Art. ID 796248.
- [16] J. P. Amaro, R. Cortesao, J. Landeck, and F. J. T. E. Ferreira, "Harvested power wireless sensor network solution for disaggregated current estimation in large buildings," *IEEE Trans. Instrum. Meas.*, vol. 64, no. 7, pp. 1847–1857, Jul. 2015.
- [17] H.-C. Lee, Y.-C. Chang, and Y.-S. Huang, "A reliable wireless sensor system for monitoring mechanical wear-out of parts," *IEEE Trans. Instrum. Meas.*, vol. 63, no. 10, pp. 2488–2497, Oct. 2014.
- [18] L. Hou and N. W. Bergmann, "Novel industrial wireless sensor networks for machine condition monitoring and fault diagnosis," *IEEE Trans. Instrum. Meas.*, vol. 61, no. 10, pp. 2787–2798, Oct. 2012.
- [19] K.-H. Chang, "Bluetooth: A viable solution for IoT? [Industry Perspectives]," *IEEE Wireless Commun.*, vol. 21, no. 6, pp. 6–7, Dec. 2014.
- [20] M. Hulea, G. Mois, S. Folea, L. Miclea, and V. Biscu, "Wi-sensors: A low power Wi-Fi solution for temperature and humidity measurement," in *Proc. 39th Annu. Conf. IEEE Ind. Electron. Soc. (IECON)*, Nov. 2013, pp. 4011–4015.