

PFC CUK Converter for BLDC Motor Drives

N. Sandhyarani¹ D. Ramesh²

¹PG Scholar, Dept of EEE(Power & Industrial Drives), Nova College Of Engineering & Technology, Hyderabad, TS, India.

² Associate Professor, Head of Dept (EEE), Nova College Of Engineering & Technology, Hyderabad, TS, India.

ABSTRACT:

The brushless dc (BLDC) servomotor drives have been widely used in aeronautics, electric vehicles, robotics, and food and chemical industries. The use of a permanent-magnet (PM) brushless dc motor (PMBLDCM) in low-power appliances is increasing because of its features of high efficiency, wide speed range, and low maintenance. Brushless DC Motors are driven by DC voltage but current commutation is controlled by solid state switches. The commutation instants are determined by the rotor position. The rotor shaft position is sensed by a Hall Effect sensor, which provides signals to the respective switches. Hall Effect sensors are used to ascertain the rotor position and from the Hall sensor outputs, it is determined whether the machine has reversed its direction. This is the ideal moment for energizing the stator phase so that the machine can start motoring in the counter clockwise direction.

BLDC motor is better choice for low-power applications. Power factor correction control technique used in bridgeless (BL) buck-boost converter. The voltage source inverter fed with DC-link capacitor, the speed control of motor is done by controlling the dc link voltage. The system was designed with filter circuit, DC-DC buck-boost converter, voltage source inverter and BLDC motor. Bridge-less buck-boost converter is designed with power factor correction technique.

There are very few publications regarding PFC in PMBLDCMs despite many PFC topologies for switched mode power supply

and battery charging applications. This work deals with an application of a PFC converter for the speed control of a PMBLDCM. For the proposed voltage controlled drive, a Boost dc-dc converter is used as a PFC converter because of its continuous input and output currents, small output filter, and wide output voltage range as compared to other single switch converters. This work presents design and digital implementation of a controller for achieving improved performance of Brushless dc (BLDC) servomotor drive. The proposed controller based BLDC motor is operated in four quadrant operation and in the extension to this work Power Factor correction is also achieved.

I. INTRODUCTION

The PMBLDCM drive, fed from a single-phase AC mains through a diode bridge rectifier (DBR) followed by a DC link capacitor, suffers from power quality (PQ) disturbances such as poor power factor (PF), increased total harmonic distortion (THD) of current at input AC mains and its high crest factor (CF). It is mainly due to uncontrolled charging of the DC link capacitor which results in a pulsed current waveform having a peak value higher than the amplitude of the fundamental input current at AC mains. Moreover, the PQ standards for low power equipment's such as IEC 61000-3-2, emphasize on low harmonic contents and near unity power factor current to be drawn from AC mains by these motors. Therefore, use of a power factor correction (PFC) topology amongst various available topologies is almost inevitable for a PMBLDCM drive.

Most of the existing systems use a boost converter for PFC as the front-end converter and an isolated DC-DC converter to produce desired output voltage constituting a two-stage PFC drive. The DC-DC converter used in the second stage is usually a fly back or forward converter for low power applications and a full-bridge converter for higher power applications. However, these two stage PFC converters have high cost and complexity in implementing two separate switch-mode converters, therefore a single stage converter combining the PFC and voltage regulation at DC link is more in demand. The single-stage PFC converters operate with only one controller to regulate the DC link voltage along with the power factor correction. The absence of a second controller has a greater impact on the performance of single-stage PFC converters and requires a design to operate over a much wider range of operating conditions.

For the proposed voltage controlled drive, a half-bridge buck DC-DC converter is selected because of its high power handling capacity as compared to the single switch converters. Moreover, it has switching losses comparable to the single switch converters as only one switch is in operation at any instant of time. It can be operated as a single-stage power

factor corrected (PFC) converter when connected between the VSI and the DBR fed from single-phase AC mains, besides controlling the voltage at DC link for the desired speed of the Air-Con compressor. A detailed modeling, design and performance evaluation of the proposed drive are presented for an air conditioner compressor driven by a PMBLDC motor of 1.5 kW, 1500 rpm rating.

II. PRINCIPLE AND OPERATION OF THE SYSTEM

The proposed speed control scheme (as shown in below Fig.) controls reference voltage at DC link as an equivalent reference speed, thereby replaces the conventional control of the motor speed and a stator current involving various sensors for voltage and current signals. Moreover, the rotor position signals are used to generate the switching sequence for the VSI as an electronic commutator of the PMBLDC motor. Therefore, rotor-position information is required only at the commutation points, e.g., every 60° electrical in the three-phase. The rotor position of PMBLDCM is sensed using Hall Effect position sensors and used to generate switching sequence for the VSI as shown in Table-3.1.

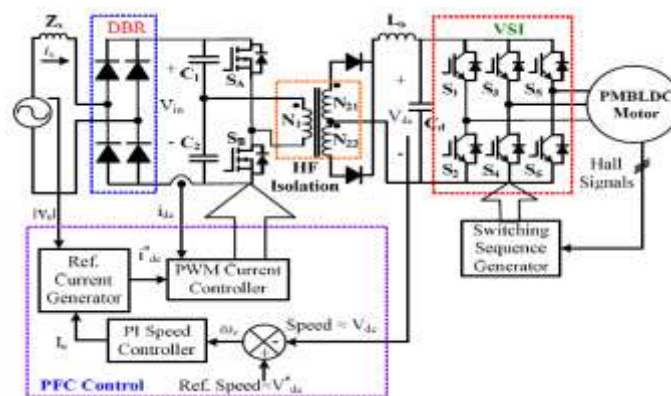

Figure.1 Control schematic of Proposed Bridge-buck PFC converter fed PMBLDCM drive

The DC link voltage is controlled by a half-bridge buck DC-DC converter based on the duty ratio (D) of the converter. For a fast and effective control with reduced size of magnetic

and filters, a high switching frequency is used; however, the switching frequency (f_s) is limited by the switching device used, operating power level and switching losses of the device.

Metal oxide field effect transistors (MOSFETs) are used as the switching device for high switching frequency in the proposed PFC converter. However, insulated gate bipolar

transistors (IGBTs) are used in VSI Bridge feeding PMBLDCM, to reduce the switching stress, as it operates at lower frequency compared to PFC switches.

H _a	H _b	H _c	E _a	E _b	E _c	S ₁	S ₂	S ₃	S ₄	S ₅	S ₆
0	0	0	0	0	0	0	0	0	0	0	0
0	0	1	0	-1	+1	0	0	0	1	1	0
0	1	0	-1	+1	0	0	1	1	0	0	0
0	1	1	-1	0	+1	0	1	0	0	1	0
1	0	0	+1	0	-1	1	0	0	0	0	1
1	0	1	+1	-1	0	1	0	0	1	0	0
1	1	0	0	+1	-1	0	0	1	0	0	1
1	1	1	0	0	0	0	0	0	0	0	0

Table .1: VSI switching sequence based on the Hall-Effect sensor signals

The PFC control scheme uses a current control loop inside the speed control loop with current multiplier approach which operates in continuous conduction mode (CCM) with average current control. The control loop begins with the comparison of sensed DC link voltage with a voltage equivalent to the reference speed. The resultant voltage error is passed through a proportional-integral (PI) controller to give the modulating current signal. This signal is multiplied with a unit template of input AC voltage and compared with DC current sensed after the DBR. The resultant current error is amplified and compared with saw-tooth carrier wave of fixed frequency (ff) in uni polar scheme to generate the PWM pulses for the half-bridge converter. For the current control of the PMBLDCM during step change of the reference voltage due to the change in the reference speed, a voltage gradient less than 800 V/s is introduced for the change of DC link voltage, which ensures the stator current of the PMBLDCM within the specified limits (i.e. double the rated current).

The main components of the proposed PMBLDCM drive are the PFC converter and PMBLDCM drive, which are modeled by mathematical equations and the complete drive is represented as a combination of these models.

A proportional integral-derivative is control loop feedback mechanism used in industrial control system. In industrial process a PI controller attempts to correct that error between a measured process variable and desired set point by calculating and then outputting corrective action that can adjust the process accordingly.

III.PI SPEED CONTROLLER DESIGN

The PI controller calculation involves two separate modes the proportional mode, integral mode. The proportional mode determine the reaction to the current error, integral mode determines the reaction based recent error. The weighted sum of the two modes output as corrective action to the control element. PI controller is widely used in industry due to its ease in design and simple structure. PI controller algorithm can be implemented as $Output(t) = K_p e(t) + K_i \int_0^t e(t) dt$

Where $e(t)$ = set reference value – actual calculated

Fig. describes the basic building blocks of the PMBLDCM drive. The drive consists of speed controller, reference current generator, PWM current controller, position sensor, the motor and IGBT based current controlled voltage source inverter (CC-VSI). The speed of

the motor is compared with its reference value and the speed error is processed in proportional-integral (PI) speed controller.

$$e(t) = \omega_{ref} - \omega_m(t)$$

$\omega_m(t)$ is compared with the reference speed ω_{ref} and the resulting error is estimated at the n th sampling instant as.

$$T_{ref}(t) = T_{ref}(t - 1) + K_p[e(t) - e(t - 1)] + K_i e(t)$$

Where K_p and K_i are the gains of PI speeds controller

The output of this controller is considered as the reference torque. A limit is put on the speed controller output depending on permissible maximum winding currents. The reference current generator block generates the three phase reference currents i_a^* , i_b^* , i_c^* using the limited peak current magnitude decided by the controller and the position sensor.

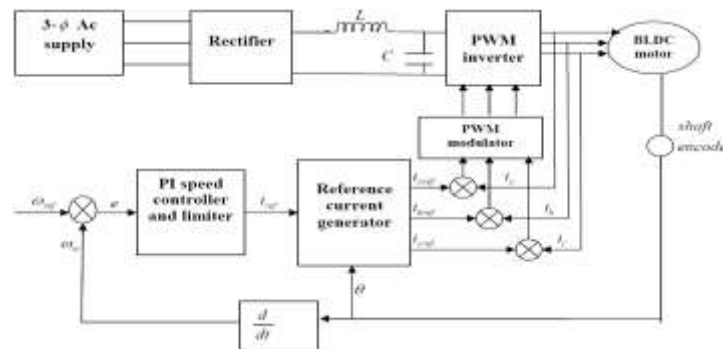

Fig 2. PI speed controller of the BLDCM drive

The reference currents have the shape of quasi-square wave in phase with respective back EMF develops constant unidirectional torque as. The PWM current controller regulates the winding currents i_a , i_b , i_c with in the small band around. The reference currents i_a^* , i_b^* , i_c^* the motor currents are compared with the reference currents and the switching commands are generated to drive the inverter devices

REFERENCE CURRENT GENERATOR

The magnitude of the three phase current ref i_{ref} is determined by using reference torque ref T_{ref} .

$$i_{ref} = T_{ref}/K_t$$

Where K_t is the torque constant. K_t Depending on the rotor position, the reference current generator block generates three-phase reference currents (i_a^* , i_b^* , i_c^*) by taking the value of Reference current magnitude as i_{ref} . The reference currents are fed to the PWM current controller. The reference current for each phase i_a^* , i_b^* , i_c^* are function of the rotor position. These reference currents are fed to the PWM current controller Rotor position signal and Reference currents shown in Table.6.1.

Rotor Position θ_r	i_a^*	i_b^*	i_c^*
0-60	i_{ref}	$-i_{ref}$	0
60-120	i_{ref}	0	$-i_{ref}$
120-180	0	i_{ref}	$-i_{ref}$
180-240	$-i_{ref}$	i_{ref}	0
240-300	$-i_{ref}$	0	i_{ref}
300-360	0	$-i_{ref}$	i_{ref}

Table.1.Rotor position signal and Reference currents

HYSTERESIS CURRENT CONTROLLER

The Hysteresis current controller contributes to the generation of the switching signals for the inverter. hysteresis-band PWM is basically an instantaneous feedback current control method of PWM where the actual

current continually tracks the command current continually tracks the command current within hysteresis-band. Fig.6.2 explains the operation principle of hysteresis-band PWM for half-bridge inverter. The control circuit generates the sine reference current and it's compared with actual phase current wave.

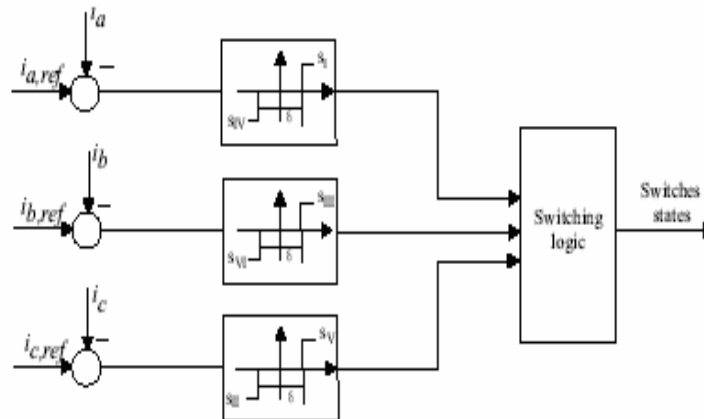

Fig.3.The structure of PWM current controller

The current exceed upper band limit the upper switch is off and lower switch is on. As the current exceed lower band limit upper switch is on and lower switch is off like this control of the other phase going on.

The switching logic is formulated as given below.

If $i_a < (i_a^* - \Delta i)$ switch 1 ON and switch 4 OFF $S_a = 1$

If $i_a < (i^*a + hb)$ switch 1 OFF and switch 4 ON $S_a = 0$

If $i_b < (i^*b - hb)$ switch 3 ON and switch 6 OFF $S_b = 1$

If $i_b < (i^*b + hb)$ switch 3 OFF and switch 6 ON $S_b = 0$

If $i_c < (i^*c - hb)$ switch 5 ON and switch 2 OFF $S_c = 1$

If $i_c < (i^*c + hb)$ switch 5 OFF and switch 2 ON $S_c = 0$

Where, hb is the hysteresis band around the three phase's references currents, according to above switching condition of the inverter output voltage are given below

$$v_a = \frac{1}{3} [2S_A - S_B - S_C]$$

$$v_b = \frac{1}{3} [-S_A + 2S_B - S_C]$$

$$v_c = \frac{1}{3} [-S_A - S_B + 2S_C].$$

Modeling of Back EMF using Rotor Position

The phase back EMF in the PMSM motor is trapezoidal in nature and is the function of the speed ω_m and rotor position angle θ_r as shown in Fig3.3. From this, the phase back EMF'S can be expressed as.

$$\begin{bmatrix} e_a \\ e_b \\ e_c \end{bmatrix} = \omega_m \lambda_m \begin{bmatrix} f_{as}(\theta_r) \\ f_{bs}(\theta_r) \\ f_{cs}(\theta_r) \end{bmatrix}$$

Where $f_{as}(\theta_r)$, $f_{bs}(\theta_r)$ and $f_{cs}(\theta_r)$ are unit function generator to corresponding to the trapezoidal induced emfs of the of BLDCM as a function of θ_r . The $f_{bs}(\theta_r)$, $f_{cs}(\theta_r)$ is similar to $f_{as}(\theta_r)$ but phase displacement of 120° .

IV. SIMULATION RESULTS

A) EXISTING RESULTS

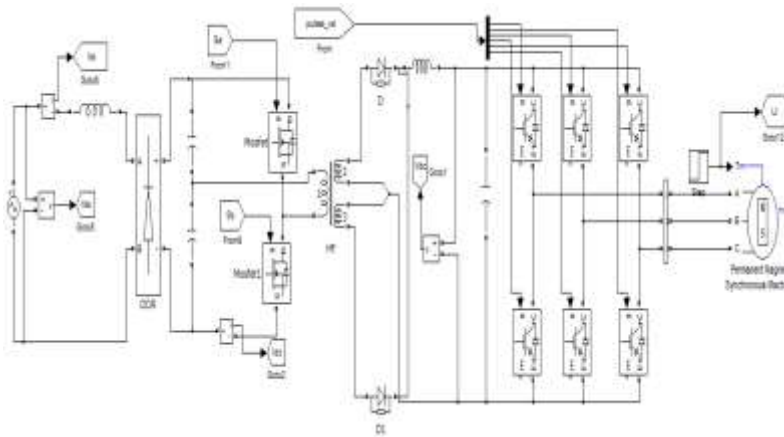

Fig 2. Simulation circuit of Proposed BLDC motor drive with front-end BL buck–boost converter

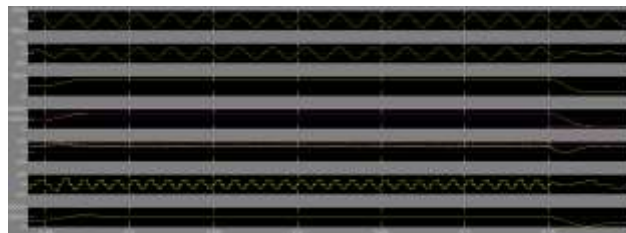

Fig 3. Dynamic performance of proposed BLDC motor drive during speed control

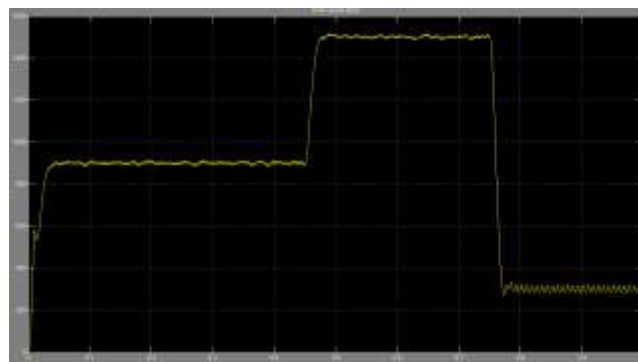

Fig4. Rotor speed of BLDC motor

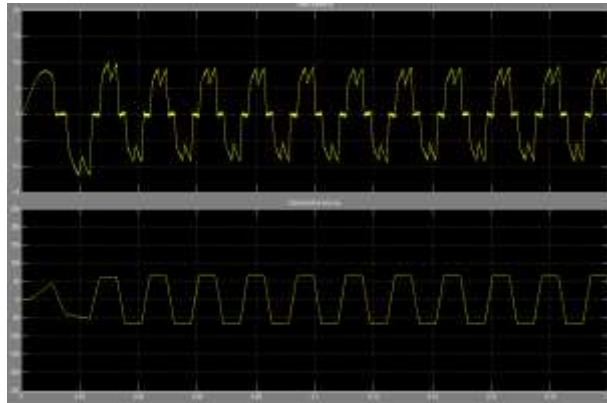

Fig5. stator current and stator back emf of BLDC motor

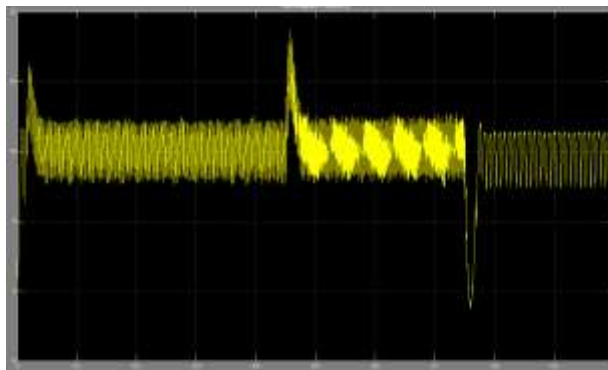

Fig6. BLDC motor torque

B)EXTENSION RESULTS

We are using cuk converter in the place of capacitor then the input side power factor maintained unity as shown in fig .and get the pure DC at the rectifier end the waveform

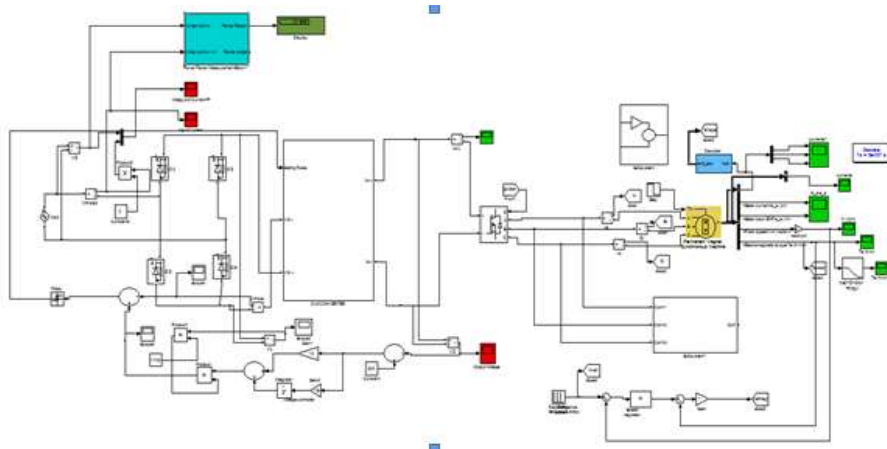

Fig 7.1: Simulink model of the PFC based BLDC drive.

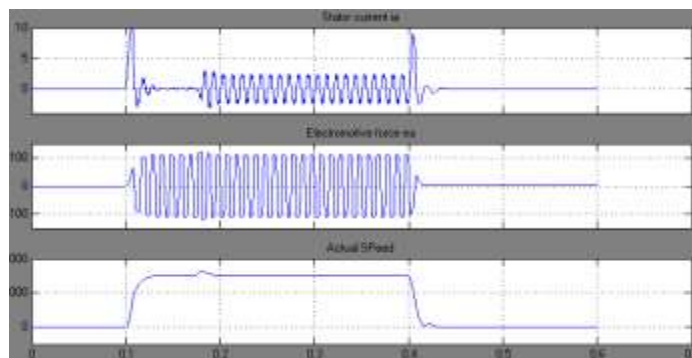

fig 8 Output model of the Simulink: stator current, back emf, actual speed.

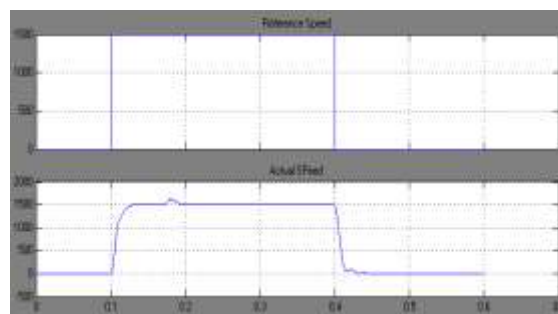

Fig: 9. Reference speed and actual speed in rpm.

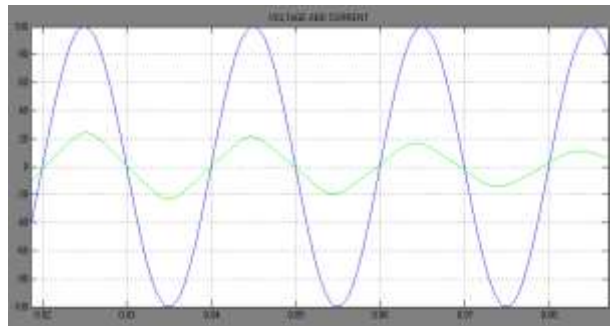

Fig: (a)

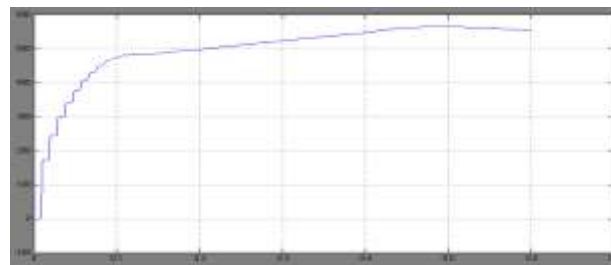

Fig:(b)

Fig:10 after connecting the cuk converter at the rectifier end (a) input voltage and current (b) dc output voltage

CONCLUSION

The digital control concept for BLDC machines has been introduced and experimentally verified. The aim of this paper is to control the four quadrants of the BLDC motor. The problem of the input ac current is also rectified then the power factor goes to nearer to unity. Increase the system life time and efficiency. The PFC Cuk converter has ensured near unity PF in a wide range of the speed and the input ac voltage.

The time taken to achieve this braking is comparatively less. The generated voltage during the regenerative mode can be returned back to the supply mains which will result in considerable saving of power. This concept may well be utilized in the rotation of spindles, embroidery machines and electric vehicles where there is frequent reversal of direction of rotation of the motor. BLDC motors are used in

Automotive, Aerospace, Consumer, Medical, Industrial Automation equipment's and instrumentation.

REFERENCES

- [1] C. L. Xia, Permanent Magnet Brushless DC Motor Drives and Controls. Hoboken, NJ, USA: Wiley, 2012.
- [2] J. Moreno, M. E. Ortuzar, and J. W. Dixon, "Energy-management system for a hybrid electric vehicle, using ultracapacitors and neural networks," *IEEE Trans. Ind. Electron.*, vol. 53, no. 2, pp. 614–623, Apr. 2006.
- [3] Y. Chen, C. Chiu, Y. Jhang, Z. Tang, and R. Liang, "A driver for the singlephase brushless dc fan motor with hybrid winding structure," *IEEE Trans. Ind. Electron.*, vol. 60, no. 10, pp. 4369–4375, Oct. 2013.

[4] H. A. Toliyat and S. Campbell, DSP-Based Electromechanical Motion Control. Boca Raton, FL, USA: CRC Press, 2004.

[5] P. Pillay and R. Krishnan, "Modeling of permanent magnet motor drives," IEEE Trans. Ind. Electron., vol. 35, no. 4, pp. 537–541, Nov. 1988.

[6] S. Singh and B. Singh, "A voltage-controlled PFC Cuk converter based PMBLDCM drive for air-conditioners," IEEE Trans. Ind. Appl., vol. 48, no. 2, pp. 832–838, Mar./Apr. 2012.

[7] B. Singh, B. N. Singh, A. Chandra, K. Al-Haddad, A. Pandey, and D. P. Kothari, "A review of single-phase improved power quality acdc converters," IEEE Trans. Ind. Electron., vol. 50, no. 5, pp. 962–981, Oct. 2003.

[8] B. Singh, S. Singh, A. Chandra, and K. Al-Haddad, "Comprehensive study of single-phase ac-dc power factor corrected converters with high-frequency isolation," IEEE Trans. Ind. Informat., vol. 7, no. 4, pp. 540–556, Nov. 2011.

[9] D. S. L. Simonetti, J. Sebastian, F. S. dos Reis, and J. Uceda, "Design criteria for SEPIC and Cuk converters as power factor pre-regulators in discontinuous conduction mode," in Proc. Int. Electron. Motion Control Conf., 1992, vol. 1, pp. 283–288