

Design and Implementation of Rhythm following flashing

¹ Syed Naveed Ahmed, ² Devella Vinay Babu, ³ Mohd Omer Nawaz, ⁴ T.Kalinga Raj Singh, ⁵ M. Hymavathi

^{1,2,3,4} B.Tech student, Dept. of ECE, Lords Institute of Engineering and Technology, Hyderabad, Telangana India.

⁵ Assistant professor, Dept. of ECE, Lords Institute of Engineering and Technology, Hyderabad, Telangana India

Abstract: The aim of this project is to develop a rhythm following flash led's which blinks following the rhythm of the music. The light which glows according to the rhythm of the music is interesting to watch. Researchers founded that the rhythmic lights speeds up the brain waves that develops the higher concentration levels. This project is implemented in such a way that the lights (LED's) glow according to the music. The rhythm following lights can be achieved by this system. This system uses a microphone through which, the audio input is picked up and amplified. Then this amplified signal triggers the sequence of LED's through an intermediate circuit. Hence the flashing of the LED's is done when an audio input is constantly changing its beat. So a Beautiful scenario of the changing LED's can be viewed with the changing beat of the music. Further the project can enhanced by using triacs and opto-isolators to use high power lamps in place of LEDs.

Key Words: Rhythm LED, Decade counter, Microphone.

I. INTRODUCTION

To those seeing them for the first time, sound and light devices may seem bizarre, like something out of a science fiction movie--the users seem laid back, out there somewhere, wired into a small box listening through headphones to some unheard sounds while eerie light pulsations flicker inside futuristic goggles. And to those encountering these devices from a background of meditative practice, the idea that one can attain heightened or meditative states of consciousness by using a machine, and the sheer technical computerized hardware of the devices themselves, must seem coldly materialistic. But while the hardware may seem new, the techniques being used are ancient. The knowledge that a flickering light can cause mysterious visual hallucinations and alterations in

consciousness is something humans have known since the discovery of fire. It must have been knowledge of great value to the ancient shamans and poets, who learned how to use the images in the flames to enhance their magic. And humans have always been keenly appreciative of the consciousness heightening powers of music, which is of course, among other things, a succession of rhythmic auditory signals. For thousands of years musicians and composers have consciously and intentionally influenced the brain states of listeners by manipulating the frequency of the rhythms and tones of their music.

Humans have also long been intrigued by the possibilities for influencing mental functioning that emerge from combining both rhythmic light and rhythmic sound stimulation. Ancient rituals for entering trance states often involved both rhythmic sounds in the form of drumbeats, clapping or chanting, and flickering lights produced by candles, torches, bonfires or long lines of human bodies rhythmically dancing, their forms passing before the fire and chopping the light into mesmerizing rhythmic flashes. Some composers of the past, such as the visionary Scriabin, actually created music intended to be experienced in combination with rhythmic light displays. Technological advances made possible even more powerful combinations of sound and light. Moving pictures developed Modern scientific research into the effects of rhythmic light and sound began in the mid-1930s when scientists discovered that the electrical rhythms of the brain tended to assume the rhythm of a flashing light stimulus, a process called entrainment. Research shifted into high gear in the late 1940s when the great British neuroscientist W. Gray Walter used an electronic strobe and advanced EEG3 equipment to investigate what he called the "flicker phenomenon." He found that rhythmic flashing lights quickly altered brainwave

activity, producing trancelike states of profound relaxation and vivid mental imagery. He was also startled to find that the flickering seemed to alter the brain-wave activity of the whole cortex instead of just the areas associated with vision. Wrote Walter: "The rhythmic series of flashes appear to be breaking down some of the physiologic barriers between different regions of the brain. This means the stimulus of flicker received by the visual projection area of the cortex was breaking bounds-its ripples were overflowing into other areas." The subjective experiences of those receiving the flashes were even more intriguing: "Subjects reported lights like comets, ultra-unearthly colors, mental colors, not deep visual ones.

II. PROPOSED METHOD

The below mentioned hardware and software requirement of the project is useful to construct the circuit. We must have seen the Disco Lights or DJ lights, which Turn ON and OFF according to the beats of the music. These lights glow according to the length and pitch (volume) of music beats, basically these are designed to pick the high intensity sound like Bass sound. So these lights follow the high pitch beats in music like drum beats, and Turn ON and OFF according to music pattern. However the sensitivity of the circuit can be increased to pick the low notes too.

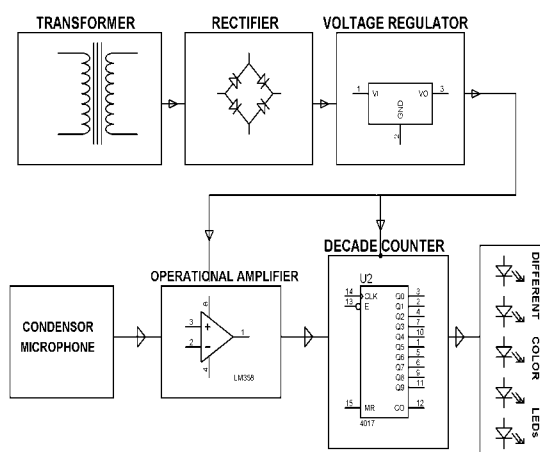

Fig.1. Block diagram

We can adjust the sensitivity of MIC by changing the value of R2 and C1, by using the formula for R-C filter: $F = 1 / (2\pi RC)$

F is the cut off frequency, means filter only allow frequency above than F. It can be easily deduced that more the value of RC, less the cut off frequency and higher the sensitivity of MIC. And higher the sensitive of circuit means MIC can pick low volume sounds, hence LEDs can glow on low pitch music also. So by adjusting its sensitivity we can make it less sensitive to reacts only on high note beats or we can also make it more sensitive to react on every little beat in the music. Here we have set its sensitivity at moderate level.

A. Condenser Mic

Condenser Mic should be connected properly in the circuit, according to its polarity. To determine the polarity of MIC one should look at mic terminals, the terminal which have three soldering lines, is the negative terminal.

B. Transistor BC547

It is a NPN transistor, which is used as a Amplifier here. NPN transistor acts as a open switch when there is no voltage applied on its Base (B) and it acts as closed switch when these is some voltage at its base. Generally 0.7 volt is enough to get it fully conducted.



C. IC 4017

The IC 4017 can be considered as one of the most useful and versatile chip having numerous electronic circuit applications. Technically it is called the Johnsons 10 stage decade counter divider. The name suggest two things, it's something to do with number 10 and counting/dividing. The number 10 is connected with the number of outputs this IC has, and these outputs become high in sequence in response to every high clock pulse applied at its input clock pin out. It means, all its 10 outputs will go through one cycle of high output sequencing from start to finish in response to 10 clocks received at its input. So in

a way it is counting and also dividing the input clock by 10 and hence the name.

Let's understand the pin outs of the IC 4017 in details and from a newcomer's point of view: Looking at the figure we see that the device is a 16 pin DIL IC, the pin out numbers are indicated in the diagram with their assignment names. The pin out which are marked as output are the pins which become logic high one after the other in sequence, meaning the first in the order is 3, so this pin is the one which first becomes high, then it shuts off and simultaneously the next pin #2 becomes, then this pin goes low and simultaneously the preceding pin #4 becomes high and so on until the last pin #11 becomes high and reverts to pin #3 to repeat the cycle.

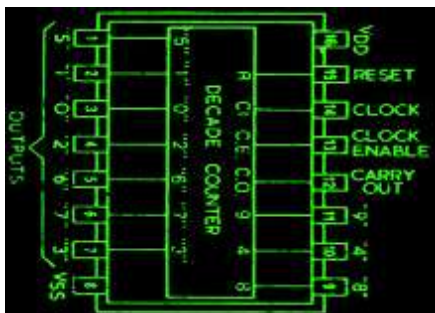

Fig.2. Pin diagram of IC 4017

Please note that the word “high” means a positive voltage that may be equal to the supply voltage of the IC, so when I say the outputs become high in a sequential manner means the outputs produce a positive voltage which shifts in a sequential manner from one output pin to the next, in a “running” DOT manner.

Now the above sequencing or shifting of the output logic from zero to high and back to zero, happens only when a clock signal is applied to the clock input of the IC which is pin #14.

Mind you, if the no clock is applied to this input, it must be assigned either to a positive supply or a negative supply, but should never be kept hanging or unconnected, as per the standard rules for all CMOS inputs.

The clock input pin #14 only responds to positive clocks or a positive signal and with each

consequent positive peak signal, the output of the IC shifts or becomes high in sequence, the sequencing of the outputs are in the order of pin outs #3, 2, 4, 7, 10, 1, 5, 6, 9, 11.

Pin #13 may be considered as the opposite of pin #14 and this pin out will respond to negative peak signals, if a clock is applied to this pin, producing the same results with the outputs as discussed above.

However normally this pin out is never used for applying the clock signals, instead pin #14 is taken as the standard clock input.

However, pin #13 needs to be assigned a ground potential, that means, must be connected to the ground for enabling the IC to function. In case pin #13 is connected to positive, the whole IC will stall and the outputs will stop sequencing and stop responding to any clock signal applied at pin #14.

Pin #15 of the IC is the reset pin input. The function of this pin is to revert the sequence back to the initial state in response to a positive potential or supply voltage, meaning the sequencing comes back to pin #3 and begins the cycle afresh, if a momentary positive supply is applied to pin #15.

If the positive supply is held connected to this pin #15, again stalls the output from sequencing and the output clamps to pin #3 making this pin-out high and fixed.

Therefore to make the IC function, pin #15 should always be connected to ground. If this pin out is intended to be used as a reset input, then it may be clamped to ground with a series resistor of 100K or any other high value, so that a positive supply now can be freely introduced to it, whenever the IC is required to be reset.

Pin #8 is the ground pin and must be connected to the negative of the supply, while pin #16 is the positive and should be terminated to the positive of the voltage supply.

Pin #12 is the carry out, and is irrelevant unless many ICs are connected in series, we will discuss it some other day. Pin #12 can be left open.

III. CONCLUSION

This project is instigated in such a way that the lights (LED's) glow according to the music. The rhythm following lights can be achieved by this system. This system uses a microphone through which, the audio input is picked up and amplified. Then this amplified signal triggers the sequence of LED's through an intermediate circuit. Hence the flashing of the LED's is done when an audio input is constantly changing its beat. So a Beautiful scenario of the changing LED's can be viewed with the changing beat of the music. Additionally the project can enhanced by using triacs and opto-isolators to use high power lamps in place of LEDs.

REFERENCES

- [1]. Available at: <http://electronicsforu.com> / electronics-projects / microcontroller-at 89c2051-rgb-colour-generator.
- [2]. <http://www.homemade-circuits.com/2011/12/how-to-understand-ic-4017-pin-outs.html>
- [3]. Available at : <https://www.elprocus.com/ic-4017-pin-configuration-application/>
- [4]. Available at : [http:// www.ikea.com/us/en/catalog/categories/departments/living_room/20515/](http://www.ikea.com/us/en/catalog/categories/departments/living_room/20515/)
- [5]. Available at : <http://www.electronicshub.org/-led-bulb/>

Author's Profile



M. Hymavathi currently working as Assistant Professor in ECE Dept. of Lords Institute of Engineering and Technology, Hyderabad, Telangana, India. She is having 4 years of teaching experience and interest of field is VLSI System Design, wireless communication, Signal Processing.



Syed Naveed Ahmed presently pursuing B.Tech 4th Year in Lords Institute of Engineering and Technology, Hyderabad, Telangana India.



Devella Vinay Babu presently pursuing B.Tech 4th Year in Lords Institute of Engineering and Technology, Hyderabad, Telangana India.



Mohd Omer Nawaz presently pursuing B.Tech 4th Year in Lords Institute of Engineering and Technology, Hyderabad, Telangana India.



T.Kalinga Raj Singh presently pursuing B.Tech 4th Year in Lords Institute of Engineering and Technology, Hyderabad, Telangana India.