

# Vehicle tracking and locking system based on gsm and gps

**<sup>1</sup>D. Venkatarami Reddy; <sup>2</sup>T. Narasimharao & <sup>3</sup>Sk. Shameem**

<sup>1</sup>Associate Professor & HOD, ECE, Madhira Institute of Technology & science, Chilkur, Nalgonda, India

<sup>2</sup> assistant professor, ECE, Madhira Institute of Technology & science, Chilkur, Nalgonda, India

<sup>3</sup>PG Scholar, ECE, Madhira Institute of Technology & science, Chilkur, Nalgonda, India

[<sup>1</sup>dvenkataramireddy@gmail.com](mailto:dvenkataramireddy@gmail.com), [<sup>2</sup>jwala.ronaldo@gmail.com](mailto:jwala.ronaldo@gmail.com), [<sup>3</sup>sk.shameem0786@gmail.com](mailto:sk.shameem0786@gmail.com)

**ABSTRACT** — *This project “Vehicle Tracking and Locking System Based on GSM and GPS” is used as which is similar to piezoelectric sensor. When vibrations are detected, SMS is sent to the owner of the car. When car owner sends back sms to project then the engine is stopped.*

## I. INTRODUCTION

In the last few decades, India has progressed at such an enormous rate that many companies have strongly established themselves here. These companies bring a huge amount of workforce with them. Arranging transportation to such a huge mass is a cumbersome task involving many intricacies. Generally, this transport is arranged through the local transport vendors on a yearly contract basis, recently happen mishaps such as burglary, rape cases etc. The development of satellite communication technology is easy to identify the vehicle locations. Vehicle tracking systems have brought this technology to the day-to-day life of the common person. Today GPS used in cars, ambulances, fleets and police vehicles are common sights on the roads of developed countries. All the existing technology support tracking the vehicle place and status.

GPS vehicle tracking ensures their safety as travelling. This vehicle tracking system found in clients vehicles as a theft prevention and rescue device. Vehicle owner or Police follow the signal emitted by the tracking system to locate a robbed vehicle in parallel the stolen vehicle engine speed going to decreased and pushed to off. After switch of the engine, motor cannot restart without permission of password.

## 1.1 PROJECT OBJECTIVE

The vehicle tracking and locking systems view analysis, the built system can segment features of moving objects from moving background and offer a collision word of warning on real-time. All the devices such as 16X2 LCD, GSM modem, Vibration sensor, Relay, Buzzer, Ignition lock and power supply are connected to microcontroller.

## 1.4 PROJECT SCOPE

This project “Vehicle Tracking and Locking System Based on GSM and GPS” is used as which is similar to piezoelectric sensor. When vibrations are detected, SMS is sent to the owner of the car. When car owner sends back sms to project then the engine is stopped.

## 1.5 PROJECT OUTLINE

The project is organized into 5 chapters, namely introduction, Literature Review, Design approach, Result analysis and conclusion. Chapter 2 contains the complete details about the Introduction of Embedded Systems and ARM Microcontroller. Chapter 3 describes about the design issues, software and hardware requirements for the Implementation of agricultural automation through webpage Chapter 4 consists of the result analysis, applications and advantages. Chapter 5 contains conclusion and proposed works to enhance the project in the future.

## II. SURVEY OF THE RELATED WORK

In [2], the hardware and software of the GPS and GSM network were developed. The proposed GPS/GSM based System has the two parts, first is a mobile unit and another is controlling station. The system processes, interfaces, connections, data

transmission and reception of data among the mobile unit and control stations are working successfully. These results are compatible with GPS technologies. In [3], a vehicle tracking system is an electronic device, installed in a vehicle to enable the owner or a third party to track the vehicle's place. This paper proposed to design a vehicle tracking system that works using GPS and GSM technology. This system built based on embedded system, used for tracking and positioning of any vehicle by using Global Positioning System (GPS) and Global system for mobile communication (GSM). This design will continuously watch a moving Vehicle and report the status of the Vehicle on demand. In [4], Face Detection System used to detect the face of the driver, and compare with the predefined face. The car owner is sleeping during the night time and someone theft the car. Then Face Detection System obtains images by one tiny web camera, which is hidden easily in somewhere in the car. Face Detection System compared the obtained images with the stored images.

If the images don't match, then the information sends to the owner through MMS. The owners get the images of the thief in mobile phone and trace the place through GPS. The place of the car and its speed displayed to the owner through SMS. The owner can recognize the thief images as well as the place of the car and can easily find out the hijackers image. This system applied in our day-to-day life.

In [5], this system provided vehicle cabin safety, security based on embedded system by modifying the existing modules. This method monitors the level of the toxic gases such as CO, LPG and alcohol within the vehicle provided alert information as alarm during the dangerous situations. The SMS sends to the authorized person through the GSM. In this method, the IR Sensor used to detect the static obstacle in front of the vehicle and the vehicle stopped if any obstacle detected. This is avoiding accidents due to collision of vehicles with any static obstacles.

In [6], Kai-Tai Song and Chih-Chieh Yang have a designed and built on a real-time visual tracking system for vehicle safety applications. In this paper built a novel feature-based vehicle-tracking algorithm, automatically detect and track several moving objects, like cars and motorcycles, ahead of the tracking vehicle. Joint with the concept of focus of expansion (FOE) and view analysis, the built system can segment features of moving objects

from moving background and offer a collision word of warning on real-time. The proposed algorithm using a CMOS image sensor and NMOS embedded processor architecture. The constructed stand-alone visual tracking system validated in real road tests. The results provided information of collision warning in urban artery with speed about 60 km/hour both at night and day times.

In [7], the remote monitoring system based on SMS and GSM was implemented. Based on the total design of the system, the hardware and software designed. In this paper, the GSM network is a medium for transmitting the remote signal. This includes two parts that are the monitoring center and the remote monitoring station. The monitoring centers consist of a computer and communication module of GSM. The software-monitoring center and the remote monitoring station implemented by using VB. The result of this demonstration shows that the system can watch and control the remote communication between the monitoring center and the remote monitoring station

In [8] this paper, the proposed tracking system based on cloud computing infrastructure. The sensors are used to monitor the fuel level, driver conditions, and speed of the vehicle. All the data transferred to cloud server using GSM enabled device. All the vehicles equipped with GPS antenna to locate the place. To avoid the drunk and drive, the alcohol sensor installed to monitor the driver status. The proposed technology significantly avoids the accident in highways.

### III. PROPOSED METHOD

In this proposed work, a novel method of vehicle tracking and locking system used to track the theft vehicle by using GPS and GSM technology. This system puts into sleeping mode while the vehicle handled by the owner or authorized person otherwise goes to active mode, the mode of operation changed by in person or remotely. If any interruption occurred in any side of the door, then the IR sensor senses the signals and SMS sends to the microcontroller. The controller issues the message about the place of the vehicle to the car owner or authorized person. When send SMS to the controller, issues the control signals to the engine motor. Engine motor speeds are gradually decreases and come to the off place. After that all the doors locked. To open the door or restart the engine, authorized person needs to enter the passwords. In this method, tracking of vehicle place easy

and doors locked automatically, thereby thief cannot get away from the car.

### 3.1 BLOCK DIAGRAM

The Block diagram of Vehicle tracking and locking system based on GSM and GPS technology is shown in

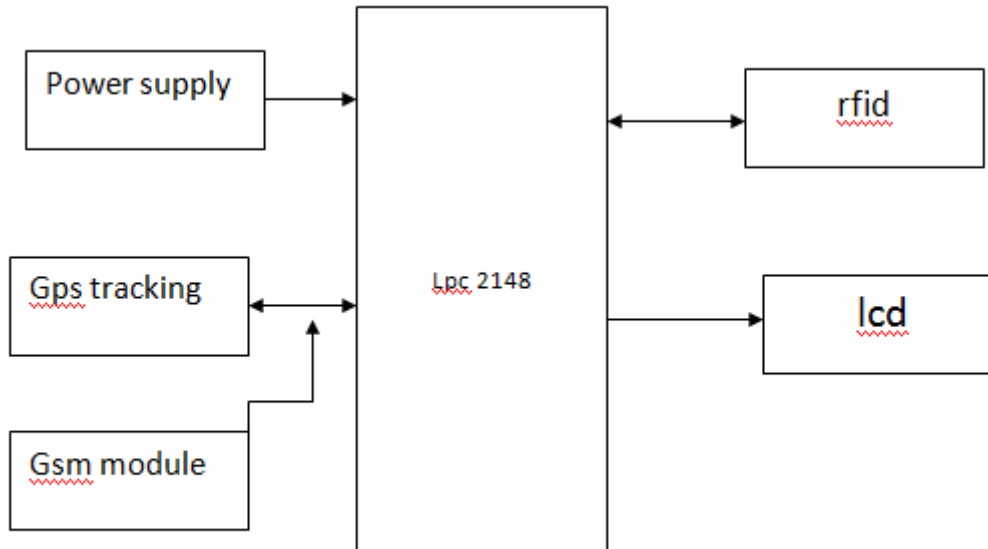

the figure1. It consists the power supply section, keyboard, GSM, GPS, microcontroller, MAX232driver, relay driver, IR Transmitter, IR receiver, LCD and door locker. The GSM board has a valid SIM card with a sufficient recharge amount to make outgoing calls. The circuits powered by +5v Dc.

### Power Supply Unit

The input to the circuit is applied from the regulated power supply. The a.c. input i.e., 230V from the mains supply is step down by the transformer to 12V and is fed to a rectifier. The output obtained from the rectifier is a

pulsating d.c voltage. So in order to get a pure d.c voltage, the output voltage from the rectifier is fed to a filter to remove any a.c components present even after rectification. Now, this voltage is given to a voltage regulator to obtain a pure constant dc voltage.

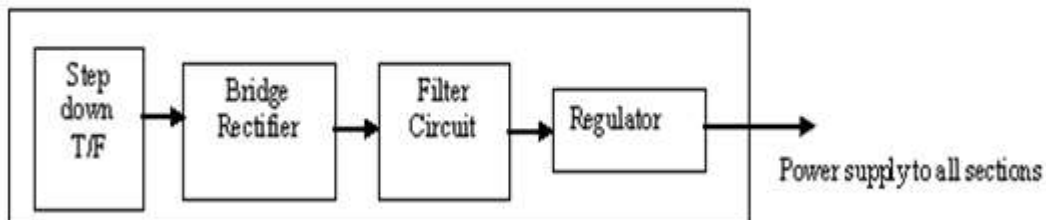

Global System For Mobile Communications  
 GSM (Global System for Mobile communications) is a

cellular network, which means that mobile phones connect to it by searching for cells in the immediate vicinity. GSM networks operate in four different

frequency ranges. Most GSM networks operate in the 900 MHz or 1800 MHz bands. Some countries in the Americas use the 850 MHz and 1900 MHz bands because the 900 and 1800 MHz frequency bands were already allocated.

The rarer 400 and 450 MHz frequency bands are assigned in some countries, where these frequencies were previously used for first-generation systems. GSM-900 uses 890–915 MHz to send information from the mobile station to the base station (uplink) and 935–960 MHz for the other direction (downlink), providing 124 RF channels (channel numbers 1 to 124) spaced at 200 kHz. Duplex spacing of 45 MHz is used. In some countries the GSM-900 band has been extended to

cover a larger frequency range. This 'extended GSM', E-GSM, uses 880–915 MHz (uplink) and 925–960 MHz (downlink), adding 50 channels (channel numbers 975 to 1023 and 0) to the original GSM-900 band. Time division multiplexing is used to allow eight full-rate or sixteen half-rate speech channels per radio frequency channel.

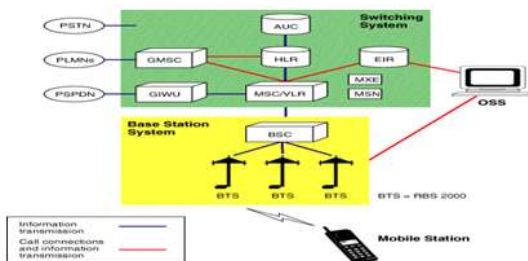

## Buzzer

A buzzer or beeper is an audio signaling device, which may be mechanical, electromechanical, or piezoelectric. Typical uses of buzzers and beepers include alarm devices, timers and confirmation of user input such as a mouse click or keystroke. Mechanical: A joy buzzer is an example of a purely mechanical buzzer. Electromechanical: Early devices were based on an electromechanical system identical to an electric bell without the metal gong. Similarly, a relay may be connected to interrupt its own actuating current, causing the contacts to buzz. Often these units were anchored to a wall or ceiling to use it as a sounding board. The word "buzzer" comes from the rasping noise that electromechanical buzzers made

Piezoelectric: A piezoelectric element may be driven by an oscillating electronic circuit or other audio signal source, driven with a piezoelectric audio amplifier. Sounds commonly used to indicate that a button has been pressed are a click, a ring or a beep.

## IV. Hardware Assembling and Testing:

First step, we need to make single side PCB layout for the given circuit diagram. After made the PCB the following process is required to complete the project.

1. Assemble all the components on the PCB based on circuit diagram. TX and RX pins of the GSM modem to pins 13 and 14 of MAX 232 and insert a valid SIM in the GSM modem.
2. Connect the GPS module according to circuit diagram.
3. This projects implemented and tested successfully by us.
4. This system is very useful and secure for car owners

## V. CONCLUSION

In this project work, we have studied and implemented a complete working model using a Microcontroller. The programming and interfacing of microcontroller has been mastered during the implementation. This work includes the study of GSM modem using sensors. The biggest advantage of using this project is each and every time the values of vibration sensor, relay, buzzer and GSM modem as well as the values are posted by using GPS technology.

## REFERENCES

- [1]. Joaquin Gutierrez, Juan Francisco Villa-Medina, Alejandra Nieto- Garibay, And Miguel ngel Porta-Gndara, "Automated Irrigation System Using A Wireless Sensor Network And Gprs Module", Ieee Transactions On Instrumentation And Measurement, Vol. 63, No. 1, January 2014.
- [2]. Vimal.P, Priyanka.V, Rajyasree.M, SanthiyaDevi.P.T, Jagadeeshraja.M, SuthanthiraVanitha.N, "A Novel Approach for Automatic Irrigation and Fertigation Using Embedded System," International Journal of VLSI and Embedded Systems- Ijves Vol 05, Article 03257; March 2014.
- [3]. Sathiyabama P, Lakshmi Priya C, Ramesh Sm, Preethi B, Mohanaarasi M, "Embedded System Design For Irrigating Field With Different Crops Using Soil Moisture Sensor," International Journal Of Innovative Research In Computer And Communication Engineering Vol. 2, Issue 8, August 2014.



[4].LiaiGao, Meng Zhang, GengChen,"An Intelligent Irrigation System Based On Wireless Sensor Network and Fuzzy Control, "Journal of Networks, Vol. 8, No. 5, May 2013.

[5].K.Prathyusha, M. ChaitanyaSuman,"Design of Embedded Systems for the Automation of Drip Irrigation," International Journal of Application or Innovation in Engineering Management (Ijaiem) Volume 1, Issue 2, October 2012.

[6].Orazio Mirabella, Senior Member, IEEE, and Michele Brischetto,"A Hybrid Wired/Wireless Networking Infrastructure.

[7].B.Sivakumar, P.Gunasekaran, T.Selvaprabhu, P.Kumaran, D.Anandan, "The Application of Wireless Sensor Network in the Irrigation Area Automatic System", IjctaJan-Feb 2012.

[8]. S.MuhammadUmair, R. Usman,"Automation Of Irrigation System Using Ann Based Controller," International Journal Of Electrical Computer Sciences Ijecs-Ijens Vol: 10No: 02.May2010

## AUTHORS

**MR.DEVIREDDY VENKATARAMI REDDY**, received the Master Of Technology degree in EMBEDDED SYSTEMS from the DR.PAULRAJ ENGINEERING COLLEGE-JNTUH, he received the Bachelor Of Engineering degree from S.A. ENGINEERING COLLEGE-ANNA UNIVERSITY. He is currently working as Associate Professor and a Head of the Department of ECE with Madhira Institute Of Technology And Sciences, kodad. His interest subjects are Embedded Systems, Microprocessors, Communication Systems, Digital Electronics and etc.



**Mr. T NARASIMHA RAO**, received the Master of Technology degree in ECE from the SANA

ENGINEERING COLLEGE-JNTUH, he received the Bachelor of Technology degree from SV ENGINEERING COLLEGE-JNTUH. He is currently working as assistant professor in the Department of ECE with Madhira Institute of Technology And Sciences, kodad. His interest subjects are VLSI, Digital Electronics, Digital Signal Processing and etc.



**SHAIK SHAMEEM** was completed her B.Tech at Madhira institute of technology and sciences, Kodad, Nalgonda, Telangana. Currently she is pursuing M.Tech in Madhira institute of technology and sciences, Kodad, Nalgonda, Telangana. Her interests in embedded systems

