

A New SVPWM Modulated Input Switched Multilevel Converter for Grid-Connected PV Energy Generation Systems

Boddapati Rupa
Mtech in Power Electronics
Dept of EEE
Swarnabharathi Institute of science & Technology, Khammam, Telangana State, India

CH. Venkateswarlu M.Tech
Assistant Professor
Dept of EEE
Swarnabharathi Institute of science & Technology, Khammam, Telangana State, India

Abstract: Solar energy is becoming more important since it produces less pollution and the cost of fossil fuel energy is rising, while the cost of solar arrays is decreasing. The proposed solar power generation system generates a sinusoidal output current that is in phase with the utility voltage and is fed into the utility. An inverter is necessary in the power conversion interface to convert the dc power to ac power. The output voltage of a solar cell array is low, a dc–dc power converter is used to boost the output voltage and match the dc bus voltage of the inverter. In this proposed inverter have eight switches and their switches operate with fundamental frequency. A new solar power generation system, which is composed of a dc/dc power converter and a new seven-level inverter, produced seven level output voltage. The proposed inverter reduced the switching losses, complexity, size and cost. This new seven-level inverter is configured using a capacitor selection circuit and a full-bridge converter. The capacitor selection circuit converts the two output voltage sources of dc–dc converter into a three-level dc voltage, and the full-bridge converter further converts three-level dc into a seven-level ac voltage. The PWM signals are generated by using fuzzy logic controllers. The performance of this proposed solar power generation system by using MAT Lab/Simulink.

Keywords: DC/DC Boost Converter, Fuzzy Logic Controller, Multilevel Inverter, Pulse Width Modulated (PWM), Solar Panel.

I. INTRODUCTION

Renewable-energy-based micro-grids have appeared to be a better way of exploiting renewable energy and reducing the environmental risks of fossil fuels. In the view of the fact that most renewable energy sources (RES), such as photovoltaic (PV), fuel cell (FC) and variable speed wind power systems, generate either DC or variable frequency/voltage AC power, a power–electronics interface is an indispensable element for the grid integration [1, 2]. In addition, modern electronic loads such as computers, plug-in hybrid electric vehicles and even traditional AC loads such as induction motors, when driven by a variable speed drive require DC power. The multilevel inverters have been considered as a key element in such grid-connected systems. Producing an acceptable sinusoidal voltage waveform at the output and boosting the output voltage are two challenging issues. Using a transformer in the boost multilevel inverter increases the size and cost and decreases the efficiency of the system due to its bulky inductors. Multilevel Inverters (MLI) began with the neutral point clamped inverter topology proposed by Nabae et al. [1].

Recently, multilevel inverters have become more attractive for researchers due to their advantages over conventional three-level pulse width-modulated (PWM) inverters. MLI has two main advantages compared with the conventional H-bridge inverters, the higher voltage capability and the reduced harmonic content in the output waveform due to the multiple dc levels. MLI is now preferred in high power/medium voltage applications due to the reduced

voltage stresses on the devices. MLI incorporates a topological structure that allows a desired output voltage to be synthesized among a set of isolated or interconnected distinct voltage sources. Numerous topologies realize this connectivity, and can be generally divided into three major categories, namely, diode clamped MLI, flying capacitor MLI, and separated dc sources (cascaded voltages) MLI. Recently renewable energy sources for grid connected applications are increased due to the world energy crisis. Injecting power to the utility must meet the world harmonic standards. Therefore, single phase MLIs become a good solution for those applications. Unfortunately one of the most particular disadvantages of MLI is the large number of the required power semiconductor switches. Although low voltage rate switches can be utilized in a multilevel inverter, each switch requires a related gate drive circuit.

This may cause the overall system to be more expensive and complex. So, in practical implementation, reducing the number of switches and gate driver circuits have become an essential point. Recently, many topologies of the MLI and its control techniques have been published. The MLI technique is implemented by adding one switch and four power diodes to the H-bridge single phase inverter. Another solution can be found by using two switches and two power diodes with the H-bridge single phase inverter. Those two systems can generate only five levels in the output voltage with less harmonic contents. The other solution is a modular inverter that can reach to any required voltage levels. But these inverters topologies can be improved by reducing their

switches without affecting their performances. The modular multilevel inverter is similar to the cascade H-bridge type. For this, a new modulation method is proposed to achieve dynamic capacitor voltage balance. A multilevel dc-link inverter is presented to overcome the problem of partial shading of individual photovoltaic sources that are connected in series. The dc bus of a full-bridge inverter is configured by several individual dc blocks, where each dc block is composed of a solar cell, a power electronic switch, and a diode. Controlling the power electronics of the dc blocks will result in a multilevel dc-link voltage to supply a full-bridge inverter and to simultaneously overcome the problems of partial shading of individual photovoltaic sources. This paper proposes a new solar power generation system as shown in Fig.1.

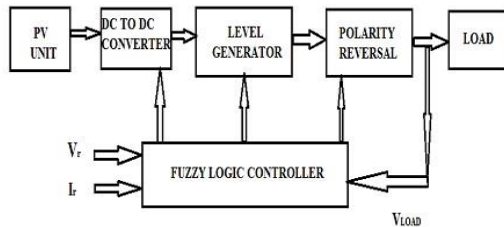

Fig1. Block Diagram of Proposed Solar Power Generation System.

The proposed solar power generation system is composed of a dc/dc power converter and a seven-level inverter. The seven level inverter is configured using a capacitor selection circuit and a full-bridge power converter, connected in cascade. The seven-level inverter contains only six power electronic switches, which simplifies the circuit configuration. Since only one power electronic switch is switched at high frequency at any time to generate the seven-level output voltage, the switching power loss is reduced, and the power efficiency is improved. The inductance of the filter inductor is also reduced because there is a seven level output voltage. In this topology fuzzy logic controllers are used to produce pulse width modulated signals. Conventional PI controller has some disadvantage i.e large steady state error and more settling time.

II. CIRCUIT CONFIGURATION

Fig.2 shows the configuration of the proposed solar power generation system.

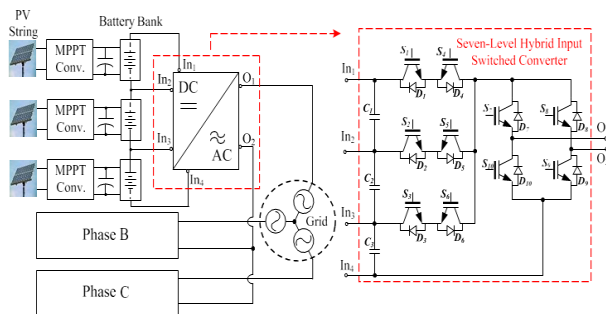

Fig2. Configuration of the proposed solar power generation system.

The proposed solar power generation system is composed of a solar cell array, a dc–dc power converter, and a new seven-level inverter. The solar cell array is connected to the dc–dc power converter, and the dc–dc power converter is a boost converter that incorporates a transformer with a turn ratio of 2:1. The dc–dc power converter converts the output power of the solar cell array into two independent voltage sources with multiple relationships, which are supplied to the seven-level inverter. This new seven-level inverter is composed of a capacitor selection circuit and a full-bridge power converter, connected in a cascade. The power electronic switches of capacitor selection circuit determine the discharge of the two capacitors while the two capacitors are being discharged individually or in series. Because of the multiple relationships between the voltages of the dc capacitors, the capacitor selection circuit outputs a three-level dc voltage. The full-bridge power converter further converts this three-level dc voltage to a seven-level ac voltage that is synchronized with the utility voltage. In this way, the proposed solar power generation system generates a sinusoidal output current that is in phase with the utility voltage and is fed into the utility, which produces a unity power factor. As can be seen, this new seven-level inverter contains only six power electronic switches, so the power circuit is simplified.

III. DC–DC POWER CONVERTER

As seen in Fig.3, the DC–DC power converter incorporates a boost converter and a current-fed forward converter. The boost converter is composed of an inductor LD, a power electronic switch SD1, and a diode, DD3. The boost converter charges capacitor C2 of the seven-level inverter. The current-fed forward converter is composed of an inductor LD, power electronic switches SD1 and SD2, a transformer, and diodes DD1 and DD2. The current-fed forward converter charges capacitor C1 of the seven-level inverter. The inductor LD and the power electronic switch SD1 of the current-fed forward converter are also used in the boost converter. Fig 3(a) shows the operating circuit of the dc–dc power converter when SD1 is turned ON. The solar cell array supplies energy to the inductor LD. When SD1 is turned OFF and SD2 is turned ON, its operating circuit is shown in Fig 3(b). Accordingly, capacitor C1 is connected to capacitor C2 in parallel through the transformer, so the energy of inductor LD and the solar cell array charge capacitor C2 through DD3 and charge capacitor C1 through the transformer and DD1 during the off state of SD1. Since capacitors C1 and C2 are charged in parallel by using the transformer, the voltage ratio of capacitors C1 and C2 is the same as the turn ratio (2:1) of the transformer. Therefore, the voltages of C1 and C2 have multiple relationships. The boost converter is operated in the continuous conduction mode (CCM). The voltage of C2 can be represented as

$$V_{c2} = \frac{1}{1-D} V_s \quad (1)$$

Where VS is the output voltage of solar cell array and D is the duty ratio of SD1. The voltage of capacitor C1 can be represented as

$$V_{c1} = \frac{1}{2(1-D)} V_s \quad (2)$$

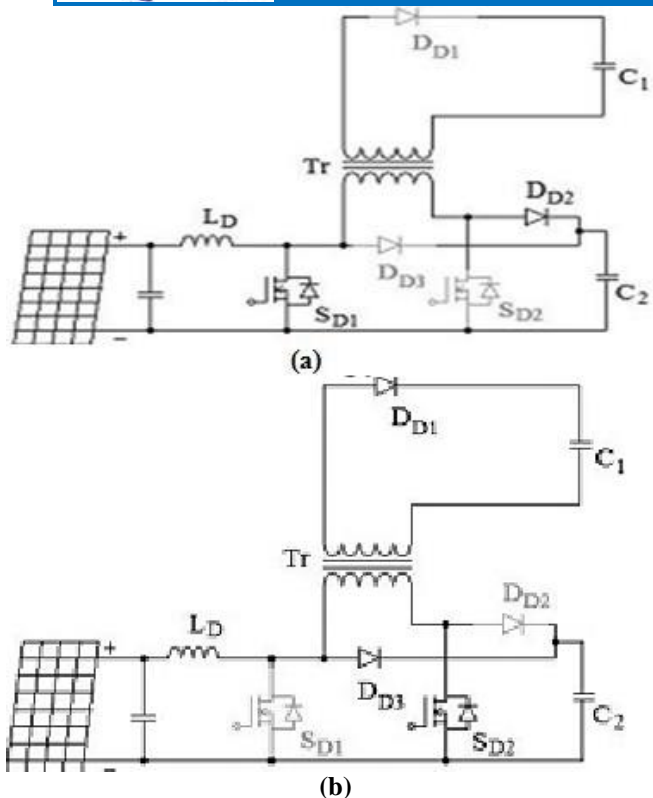

Fig.3. Operation of dc-dc power converter: (a) S_{D1} s on and (b) S_{D1} s off.

It should be noted that the current of the magnetizing inductance of the transformer increases when S_{D2} is in the ON state. Conventionally, the forward converter needs a third demagnetizing winding in order to release the energy stored in the magnetizing inductance back to the power source. However, in the proposed dc-dc power converter, the energy stored in the magnetizing inductance is delivered to capacitor C_2 through D_{D2} and S_{D1} when S_{D2} is turned OFF. Since the energy stored in the magnetizing inductance is transferred forward to the output capacitor C_2 and not back to the dc source, the power efficiency is improved. In addition, the power circuit is simplified because the charging circuits for capacitors C_1 and C_2 are integrated. Capacitors C_1 and C_2 are charged in parallel by using the transformer, so their voltages automatically have multiple relationships. The control circuit is also simplified.

IV. SEVEN-LEVEL INVERTER

As seen in Fig1, the seven-level inverter is composed of a capacitor selection circuit and a full-bridge power converter, which are connected in cascade. The operation of the seven level inverter can be divided into the positive half cycle and the negative half cycle of the utility. For ease of analysis, the power electronic switches and diodes are assumed to be ideal, while the voltages of both capacitors C_1 and C_2 in the capacitor selection circuit are constant and equal to $V_{dc}/3$ and $2V_{dc}/3$, respectively. Since the output current of the solar power generation system will be controlled to be sinusoidal and in phase with the utility voltage, the output current of the seven-level inverter is also positive in the positive half cycle of the utility. The operation of the seven-level inverter in the positive half cycle of the utility can be further divided into four modes, as shown in Fig 3.

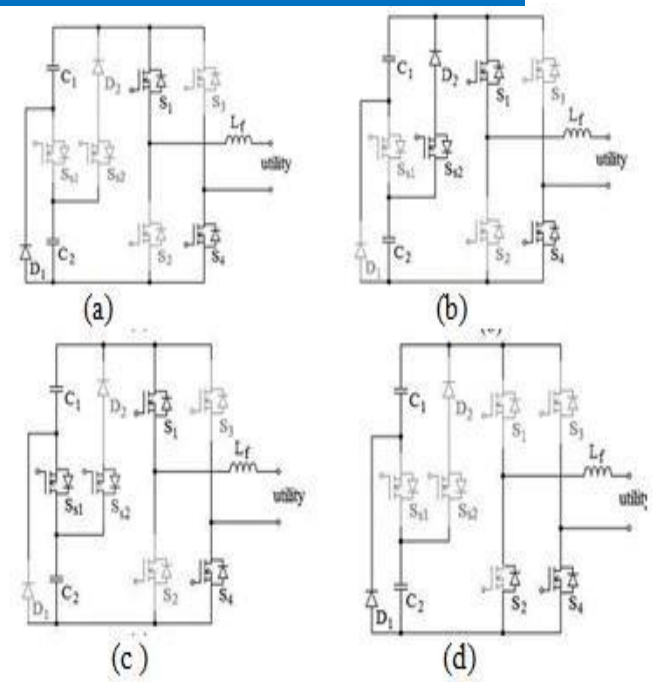

Fig 4 Operation of the seven-level inverter in the positive half cycle, (a) Mode 1, (b) mode 2, (c) mode 3, and (d) mode 4.

Mode 1: The operation of mode 1 is shown in Fig 4(a). Both S_{S1} and S_{S2} of the capacitor selection circuit are OFF, so C_1 is discharged through D_1 and the output voltage of the capacitor selection circuit is $V_{dc}/3$. S_1 and S_4 of the full-bridge power converters are ON. At this point, the output voltage of the seven-level inverter is directly equal to the output voltage of the capacitor selection circuit, which means the output voltage of the seven-level inverter is $V_{dc}/3$.

Mode 2: The operation of mode 2 is shown in Fig 4(b). In the capacitor selection circuit, S_{S1} is OFF and S_{S2} is ON, so C_2 is discharged through S_{S2} and D_2 and the output voltage of the capacitor selection circuit is $2V_{dc}/3$. S_1 and S_4 of the full-bridge power converter are ON. At this point, the output voltage of the seven-level inverter is $2V_{dc}/3$.

Mode 3: The operation of mode 3 is shown in Fig 4(c). In the capacitor selection circuit, S_{S1} is ON. Since D_2 has a reverse bias when S_{S1} is ON, the state of S_{S2} cannot affect the current flow. Therefore, S_{S2} may be ON or OFF, to avoiding switching of S_{S2} . Both C_1 and C_2 are discharged in series and the output voltage of the capacitor selection circuit is V_{dc} . S_1 and S_4 of the full-bridge power converter are ON. At this point, the output voltage of the seven-level inverter is V_{dc} .

Mode 4: The operation of mode 4 is shown in Fig 4(d). Both S_{S1} and S_{S2} of the capacitor selection circuit are OFF. The output voltage of the capacitor selection circuit is $V_{dc}/3$. Only S_4 of the full-bridge power converter is ON. Since the output current of the seven-level inverter is positive and passes through the filter inductor, it forces the anti parallel diode of S_2 to be switched ON for continuous conduction of the filter inductor current. At this point, the output voltage of the seven level inverter is zero. Therefore, in the positive half cycle, the output voltage of the seven-level inverter has four levels: V_{dc} , $2V_{dc}/3$, $V_{dc}/3$, and 0.

In the negative half cycle, the output current of the seven-level inverter is negative. The operation of the seven-level inverter can also be further divided into four modes, as shown in Fig 5. A comparison with Fig 4 shows that the operation of the capacitor selection circuit in the negative half cycle is the same as that in the positive half cycle. The difference is that S_2 and S_3 of the full-bridge power converter are ON during modes 5, 6, and 7, and S_2 is also ON during mode 8 of the negative half cycle. Accordingly, the output voltage of the capacitor selection circuit is inverted by the full-bridge power converter, so the output voltage of the seven-level inverter also has four levels: $-V_{dc}$, $-2V_{dc}/3$, $-V_{dc}/3$, and 0. In summary, the output voltage of the seven-level inverter has the voltage levels: V_{dc} , $2V_{dc}/3$, $V_{dc}/3$, 0 , $-V_{dc}/3$, $-2V_{dc}/3$, and $-V_{dc}$. The seven-level inverter is controlled by the current-mode control, and pulse-width modulation (PWM) is used to generate the control signals for the power electronic switches. The output voltage of the seven-level inverter must be switched in two levels, according to the utility voltage. One level of the output voltage is higher than the utility voltage in order to increase the filter inductor current, and the other level is lower than the utility voltage, in order to decrease the filter inductor current. In this way, the output current of the seven-level inverter can be controlled to trace a reference current.

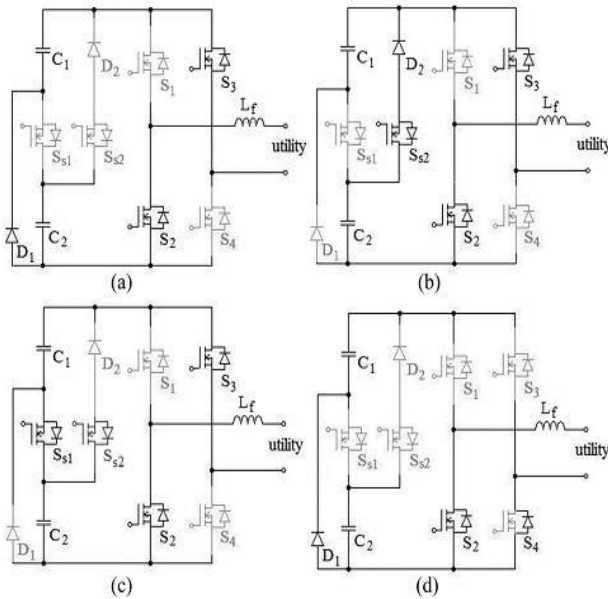

Fig.5. Operation of the seven-level inverter in the negative half cycle: (a) Mode 5, (b) mode 6, (c) mode 7, and (d) mode 8.

Accordingly, the output voltage of the seven-level inverter must be changed in accordance with the utility voltage. In the positive half cycle, when the utility voltage is smaller than $V_{dc}/3$, the seven-level inverter must be switched between modes 1 and 4 to output a voltage of $V_{dc}/3$ or 0. Within this voltage range, S_1 is switched in PWM. The duty ratio d of S_1 can be represented as

$$d = v_m / V_{tri} \quad (3)$$

Where v_m and V_{tri} are the modulation signal and the amplitude of carrier signal in the PWM circuit, respectively.

The output voltage of the seven-level inverter can be written as

$$v_o = d \cdot V_{dc} / 3 = k_{pwm} v_m \quad (4)$$

Where k_{pwm} is the gain of inverter, which can be written as

$$k_{pwm} = V_{dc} / 3V_{tri} \quad (5)$$

Fig .5(a) shows the simplified model for the seven-level inverter when the utility voltage is smaller than $V_{dc}/3$. The closed loop transfer function can be derived as

$$I_o = \frac{k_{pwm} G_c / L_f}{s + k_i k_{pwm} G_c / L_f} I_o^* - \frac{1/L_f}{s + k_i k_{pwm} G_c / L_f} V_u \quad (6)$$

Where G_c is the current controller and k_i is the gain of the current detector. The seven-level inverter is switched between modes 2 and 1, in order to output a voltage of $2V_{dc}/3$ or $V_{dc}/3$ when the utility voltage is in the range ($V_{dc}/3$, $2V_{dc}/3$). Within this voltage range, S_{S2} is switched in PWM. The duty ratio of S_{S2} is the same as (3). However, the output voltage of seven-level inverter can be written as

$$v_o = d \cdot V_{dc} / 3 + V_{dc} / 3 = k_{pwm} v_m + V_{dc} / 3. \quad (7)$$

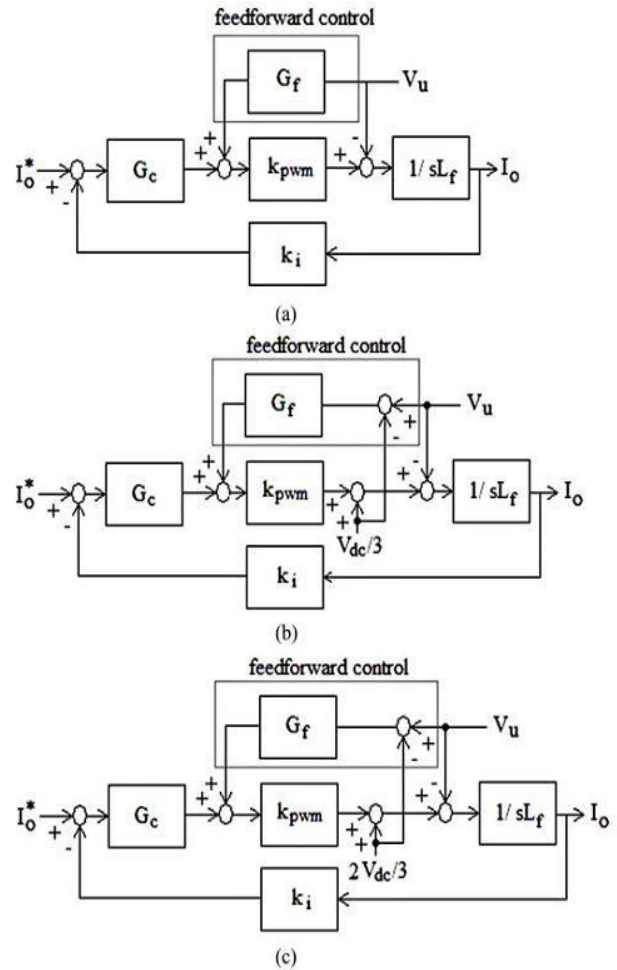

Fig 6. Model of the seven-level inverter under different range of utility voltage, (a) in the range of smaller than $V_{dc}/3$, (b) in the range of ($V_{dc}/3$, $2V_{dc}/3$), (c) in the range of higher than $2V_{dc}/3$.

Fig 6(b) shows the simplified model for the seven-level inverter when the utility voltage is within this voltage range. The closed-loop transfer function can be derived as

$$I_o = \frac{k_{pwm} G_c / L_f}{s + k_i k_{pwm} G_c / L_f} I_o^* - \frac{1/L_f}{s + k_i k_{pwm} G_c / L_f} (V_u - V_{dc}/3). \quad (8)$$

The seven-level inverter is switched between modes 3 and 2 in order to output a voltage of $V_{dc} 2V_{dc}/3$, when the utility voltage is in the range $(2V_{dc}/3, V_{dc})$. Within this voltage range, S_{S1} is switched in PWM and S_{S2} remains in the ON state to avoid switching of S_{S2} . The duty ratio of S_{S1} is the same as (3). However, the output voltage of seven-level inverter can be written as

$$v_o = d \cdot V_{dc}/3 + 2V_{dc}/3 = k_{pwm} v_m + 2V_{dc}/3. \quad (9)$$

Fig.5(c) shows the simplified model for the seven-level inverter when the utility voltage is within this voltage range. The closed-loop transfer function can be derived as

$$I_o = \frac{k_{pwm} G_c / L_f}{s + k_i k_{pwm} G_c / L_f} I_o^* - \frac{1/L_f}{s + k_i k_{pwm} G_c / L_f} (V_u - 2V_{dc}/3). \quad (10)$$

TABLE I: States of Power Electronic Switches for a Seven-Level Inverter

positive half cycle						
	S_{S1}	S_{S2}	S_1	S_2	S_3	S_4
$ v_u < V_{dc}/3$	off	off	PWM	off	off	on
$2V_{dc}/3 > v_u > V_{dc}/3$	off	PWM	on	off	off	on
$ v_u > 2V_{dc}/3$	PWM	on	on	off	off	on
negative half cycle						
$ v_u < V_{dc}/3$	off	off	off	on	PWM	off
$2V_{dc}/3 > v_u > V_{dc}/3$	off	PWM	off	on	on	off
$ v_u > 2V_{dc}/3$	PWM	on	off	on	on	off

As seen in (6), (8), and (10), the second term is the disturbance. Hence, a feed forward control, which is also shown in Fig.5, should be used to eliminate the disturbance, and the gain G_f should be $1/k_{pwm}$. In the negative half cycle, the seven-level inverter is switched between modes 5 and 8, in order to output a voltage of $-V_{dc}/3$ or 0, when the absolute value of the utility voltage is smaller than $V_{dc}/3$. Accordingly, S_3 is switched in PWM. The seven level inverter is switched in modes 6 and 5 to output a voltage of $-2V_{dc}/3$ or $-V_{dc}/3$ when the utility voltage is in the range $(-V_{dc}/3, -2V_{dc}/3)$. Within this voltage range, S_{S2} is switched in PWM. The seven-level inverter is switched in modes 7 and 6 to output a voltage of $-V_{dc}$ or $-2V_{dc}/3$, when the utility voltage is in the range $(-2V_{dc}/3, -V_{dc})$. At this voltage range, S_{S1} is switched in PWM and S_{S2} remains in the ON state to avoid switching of S_{S2} . The simplified model for the seven-level inverter in the negative half cycle is the similar to that for the positive half cycle. Since only six power electronic switches are used in the proposed seven-level inverter, the power circuit is significantly simplified compared with a conventional seven-level inverter.

The states of the power electronic switches of the seven-level inverter, as detailed previously, are summarized in Table I. It can be seen that only one power electronic switch is switched in PWM within each voltage range and the

change in the output voltage of the seven-level inverter for each switching operation is $V_{dc}/3$, so switching power loss is reduced. Figs 3 and 4 show that only three semiconductor devices are conducting in series in modes 1, 3, 4, 5, 7, and 8 and four semiconductor devices are conducting in series in modes 2 and 6. This is superior to the conventional multi-level inverter topologies, in which at least four semiconductor devices are conducting in series. Therefore, the conduction loss of the proposed seven-level inverter is also reduced slightly. The drawback of the proposed seven-level inverter is that the voltage rating of the full-bridge converter is higher than that of conventional multilevel inverter topologies. The leakage current is an important parameter in a solar power generation system for transformer less operation. The leakage current is dependent on the parasitic capacitance and the negative terminal voltage of the solar cell array respect to ground. To reduce the leakage current, the filter inductor L_f should be replaced by a symmetric topology.

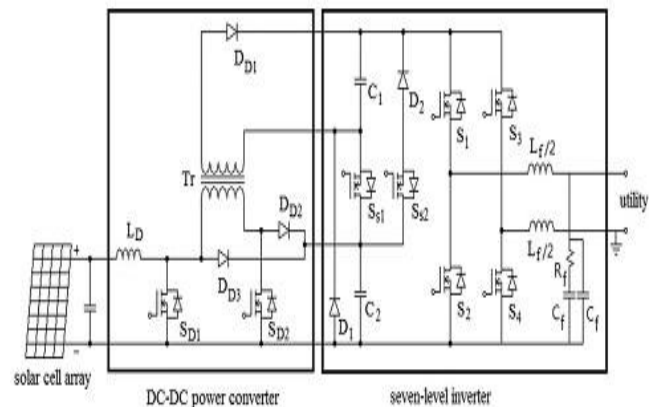

Fig.7. Configuration of the proposed solar power generation system for suppressing the leakage current.

A. Seven-Level Inverter

Fig.7 shows the control block diagram for the seven-level inverter. The control object of the seven-level inverter is its output current, which should be sinusoidal and in phase with the utility voltage. The utility voltage is detected by a voltage detector, and then sent to a phase-lock loop (PLL) circuit in order to generate a sinusoidal signal with unity amplitude. The voltage of capacitor C_2 is detected and then compared with a setting voltage. The compared result is sent to a PI controller. Then, the outputs of the PLL circuit and the PI controller are sent to a multiplier to produce the reference signal, while the output current of the seven-level inverter is detected by a current detector. The reference signal and the detected output current are sent to absolute circuits and then sent to subtract or, and the output of the subtract or is sent to a current controller. The detected utility voltage is also sent to an absolute circuit and then sent to a comparator circuit, where the absolute utility voltage is compared with both half and whole of the detected voltage of capacitor C_2 , in order to determine the range of the operating voltage. The comparator circuit has three output signals, which correspond to the operation voltage ranges, $(0, V_{dc}/3)$, $(V_{dc}/3, 2V_{dc}/3)$, and $(2V_{dc}/3, V_{dc})$.

The feed-forward control eliminates the disturbances of the utility voltage, $V_{dc}/3$ and $2V_{dc}/3$, as shown in (6), (8), and

(10). The absolute value of the utility voltage and the outputs of the compared circuit are sent to a feed-forward controller to generate the feed-forward signal. Then, the output of the current controller and the feed-forward signal are summed and sent to a PWM circuit to produce the PWM signal. The detected utility voltage is also compared with zero, in order to obtain a square signal that is synchronized with the utility voltage. Finally, the PWM signal, the square signal, and the outputs of the compared circuit are sent to the switching signal processing circuit to generate the control signals for the power electronic switches of the seven-level inverter, according to Table I. The current controller controls the output current of the seven level inverter, which is a sinusoidal signal of 60 Hz. Since the feed-forward control is used in the control circuit, the current controller can be a simple amplifier, which gives good tracking performance. As can be seen in (6), (8), and (10), the gain of the current controller determines the bandwidth and the steady state error. The gain of the current controller must be as large as possible in order to ensure a fast response and a low steady-state error. But the gain of the current controller is limited because the bandwidth of the power converter is limited by the switching frequency.

B. DC-DC Power Converter

Fig.7 shows the control block diagram for the dc-dc power converter. The input for the DC-DC power converter is the output of the solar cell array. A ripple voltage with a frequency that is double that of the utility appears in the voltages of C_1 and C_2 , when the seven-level inverter feeds real power into the utility. The MPPT function is degraded if the output voltage of solar cell array contains a ripple voltage. Therefore, the ripple voltages in C_1 and C_2 must be blocked by the dc-dc power converter to provide improved MPPT. Accordingly, dual control loops, an outer voltage control loop and an inner current control loop, are used to control the dc-dc power converter. Since the output voltages of the DC-DC power converter comprises the voltages of C_1 and C_2 , which are controlled by the seven-level inverter, the outer voltage control loop is used to regulate the output voltage of the solar cell array.

The inner current control loop controls the inductor current so that it approaches a constant current and blocks the ripple voltages in C_1 and C_2 . The perturbation and observation method is used to provide MPPT. The output voltage of the solar cell array and the inductor current are detected and sent to a MPPT controller to determine the desired output voltage for the solar cell array. Then the detected output voltage and the desired output voltage of the solar cell array are sent to a subtract or and the difference is sent to a PI controller. The output of the PI controller is the reference signal of the inner current control loop. The reference signal and the detected inductor current are sent to a subtract or and the difference is sent to an amplifier to complete the inner current control loop. The output of the amplifier is sent to the PWM circuit. The PWM circuit generates a set of complementary signals that control the power electronic switches of the dc-dc power converter.

V. CONTROL BLOCK

Fuzzy logic controller is used to reduce the rise time, settling time to almost negligible and also try to remove the

time delay and inverted response. It works with uncertain and imprecise knowledge. It provides an approximate but effective means of describing the behaviour of systems that are too complex, ill-defined, or not easily analyzed mathematically. Fuzzy variables are processed using a system called a fuzzy logic controller. It involves fuzzification, fuzzy inference, and defuzzification. The fuzzification process converts a crisp input value to a fuzzy value. The fuzzy inference is responsible for drawing conclusions from the knowledge base. The defuzzification process converts the fuzzy control actions into a crisp control action. Membership function values are assigned to the linguistic variables, using seven fuzzy subsets: NB (negative big), NS (negative small), ZE (zero), PS (positive small), and PB (positive big). The set of rules designed in fuzzy logic controller are shown in Table 1. Based on the rules framed in the table, the fuzzy logic controller controls the switches present in the dc/dc boost converter and single H-bridge inverter.

TABLE II: Rule based Fuzzy Logic Controller

$E \setminus CE \rightarrow$	NB	NS	ZE	PS	PB
NB	NB	NB	NS	NS	ZE
NS	NB	NS	NS	ZE	PS
ZE	NS	NS	ZE	PS	PS
PS	NS	ZE	PS	PS	PB
PB	ZE	PS	PS	PB	PB

VI. MATALAB/SIMULINK

RESULTSS Simulink results of this paper is shown in bellow Figs.8 to 14.

Case i: Seven level inverter for RES By using PI controller

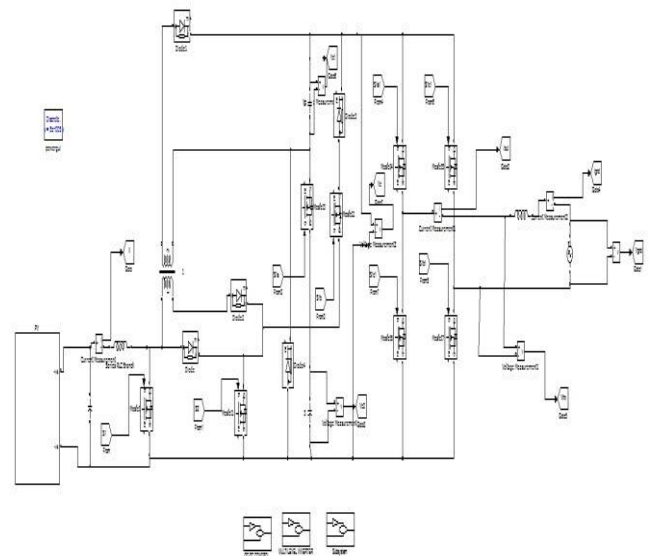

Fig.8. Simulink circuit for proposed seven level inverter using PI controller.

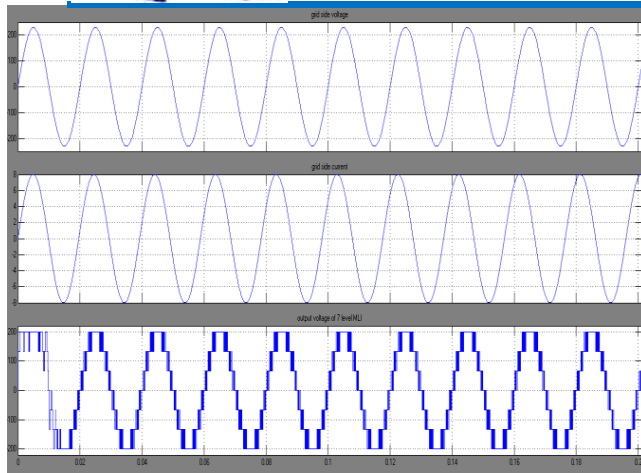

Fig.9. simulation results for the ac side of the seven-level inverter: (a) grid voltage, (b) inverter current (c) output voltage of seven-level inverter.

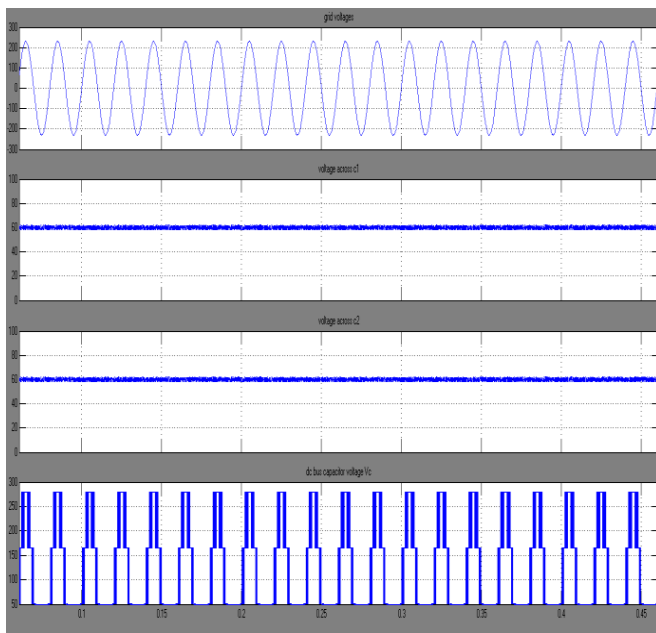

Fig. 10. simulation results for (a) grid voltage, (b) voltage of capacitor C1, (c) voltage of capacitor C2, and (d) output voltage of the capacitor selection circuit.

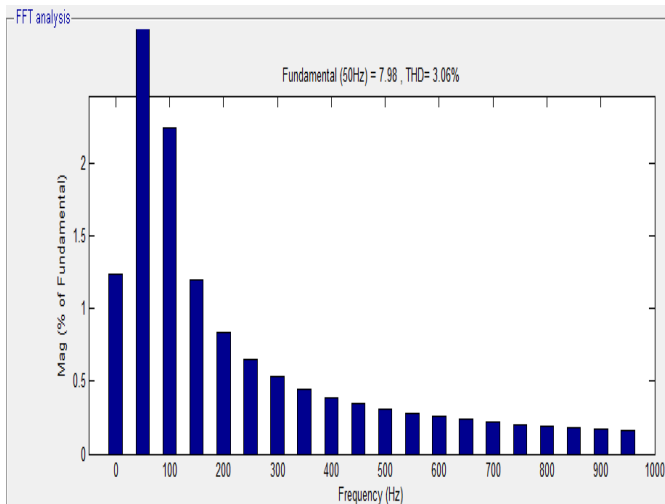

Fig.11. FFT analysis for inverter current.

CaseII: Seven level inverter for RES By using fuzzy controller

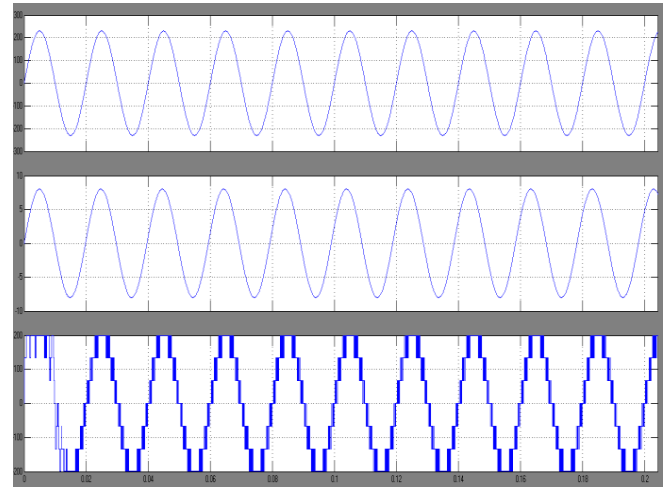

Fig.12. simulation results for the ac side of the seven-level inverter: (a) grid voltage, (b) inverter current (c) output voltage of seven-level inverter.

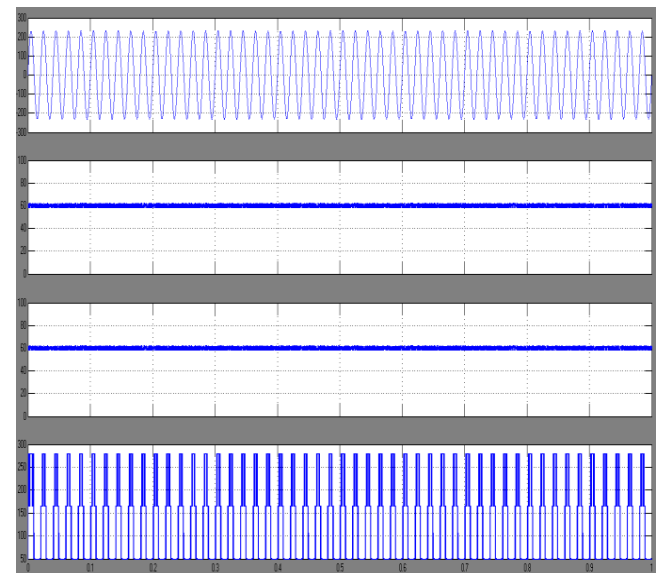

Fig. 13. simulation results for (a) grid voltage, (b) voltage of capacitor C1, (c) voltage of capacitor C2, and (d) output voltage of the capacitor selection circuit.

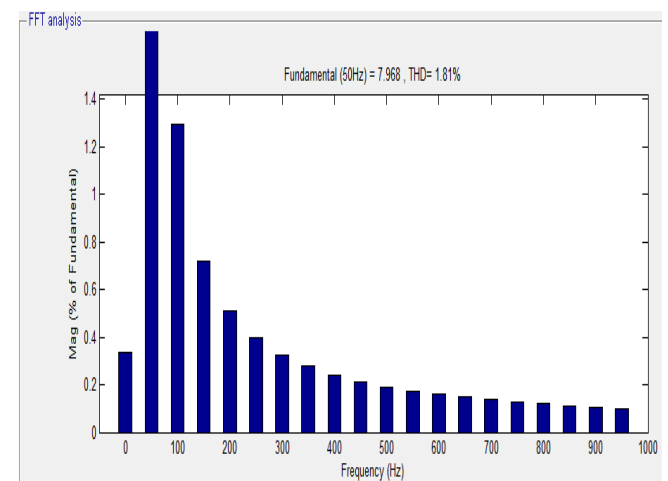

Fig.14. FFT analysis for inverter current.

VII. CONCLUSION

The proposed technique has some features such as it reduces the cost of the overall system, compact size as well as an increased efficiency. With the help of lower number of switches, seven-level of output voltages are generated and thus it reduces the switching loss and conduction losses. The THD of seven-level inverter is less compare to the five-level and three-level inverter. The fuzzy logic controller could control the switches present in the boost converter and H-bridge inverter. For the seven level of output, only six power electronic switches are used and only one switch will operate at high frequency at any time. For further implementation, the inverter level can extend by cascading additional H-bridge inverter. There may be some loss due to the transformer and this can also overcome by providing transformer less connection with its replacement. As the inverter level increases, the filter requirements and harmonic content decreases.

VIII. REFERENCES

- [1] Jinn-Chang Wu, Member, IEEE, and Chia-Wei Chou, A Solar Power Generation System With a Seven-Level Inverter, IEEE Trans. Power Electron., vol. 29, no. 7, pp. 3454–3462, July.2014.
- [2] Fan Zhang, KaryThanapalan, Andrew Procter, Stephen Carr, and Jon Maddy, Adaptive Hybrid Maximum Power Point Tracking Method for a Photovoltaic System IEEE Trans. Energy Conversion, vol. 28, no. 2, pp.353-360, June.2013.
- [3] J. D. Barros, J. F. A. Silva, and E.G.A Jesus, —Fast-predictive optimal control of NPC multilevel converters, IEEE Trans. Ind. Electron., vol. 60, no. 2, pp. 619–627, Feb. 2013.
- [4] J. Chavarria, D. Biel, F. Guinjoan, C.Meza, and J. J. Negroni, —Energy balance control of PV cascaded multilevel grid-connected inverters under level-shifted and phase-shifted PWMs, IEEE Trans. Electron., vol. 60, no. 1, pp. 98–111, Jan.2013.
- [5] X. She, A. Q. Huang, T. Zhao, and G. Wang, —Coupling effect reduction of a voltage-balancing controller in single-phase cascaded multilevel converters, IEEE Trans. Power Electron., vol. 27, no. 8, pp. 3530–3543, Aug.2012.
- [6] S. Choi and M. Saedifard, —Capacitor voltage balancing of flying capacitor multilevel converters by space vector PWM, IEEE Trans. Power Delivery, vol. 27, no. 3, pp. 1154–1161, Jul.2012.
- [7] R. A. Mastromauro, M. Liserre, and A. Dell' Aquila, —Control issues in single-stage photovoltaic systems: MPPT, current and voltage control, IEEE Trans. Ind. Informat., vol. 8, no. 2, pp. 241–254, May.2012.
- [8] L. Maharjan, T. Yamagishi, and H. Akagi, —Active-power control of individual converter cells for a battery energy storage system based on a multilevel cascade PWM converter, IEEE Trans. Power Electron., vol. 27, no. 3, pp. 1099–1107, Mar.2012.
- [9] N. A. Rahim, K. Chaniago, and J.Selvaraj, —Single-phase seven-level grid-connected inverter for photovoltaic system, IEEE Trans. Ind. Electr., vol. 58, no. 6, pp. 2435–2443, Jun. 2011.

[10] Huan-Liang Tsai, Ci-Siang Tu, and Yi-Jie Su, Member, —Development of Generalized Photovoltaic Model Using MATLAB/SIMULINK, IAENG,WCECS, San Francisco, USA October 22 - 24, 2008.

[11] Ravi, A., Manoharan, P.S., Vijay Anand, J.: Modeling and simulation of three phase multilevel inverter for grid connected photovoltaic systems', Solar Energy, 2011, 85, pp.2811-2818.

[12] A Ravi, PS Manoharan, M ValanRajkumar Harmonic Reduction of Three-Phase Multilevel Inverter for Grid Connected Photovoltaic System Using Closed Loop Switching Control' 2012, International Review on Modelling& Simulations 5 (5),pp.1934-1942.



Mr.CH. VENKATESWARLU was born in India in the year of 1981 .He received B.Tech degree in Electrical and Electronics Engineering in the year of 2004 at VRSEC & M. Tech degree in Control System Engg in the year of 2007 from JNTUA,Ananthapur
Email id :chevurisbit@gmail.com.



Ms.Boddapati Rupa was born in India.He pursuing M.Tech degree in Power electronics in EEE Department in Swarna Bharathi Institute of Science & Technology , Khammam , Telangana State, India.
mailid: boddapatirupal234@gmail.com