

An Investigation on Real Time Power Management for the Streetlight System

¹Deepraj S Deshmukh, ²Dr.M.B.Ramamurti

¹Research Scholar, Rayalaseema University, Kurnool, AP, India.

²Professor CMRCET, Department of ECE, Kondlakoya (v) Medchal Road, Hyderabad-501 401. (TS), India.

¹ddeshmukhji@gmail.com, ²mbrmurthy@yahoo.com

ABSTRACT: - Traditional control and maintenance of street lamps is not enough more to modernization need. The main focus of proposed system is to optimize management and efficiency of street lighting systems and realize a kind of higher autoimmunization, more credible and efficient long-distance monitoring and control system. It uses a sensor combination to control and guarantee the desired system parameters; the information is transferred point by point using ZigBee transmitters and receivers and is sent to a control terminal used to check the state of the street lamps and to take appropriate measures in case of failure.

Keywords: - Control system, Lighting system, Sensors, Wireless networks, ZigBee.

I. INTRODUCTION

Lighting systems in the public sector are still designed according to the old standards reliability and they often do not have advantage of the latest technological development, the use of new technologies for the sources of light and also combination of sensors. There are three areas to be concentrated to achieve the high

efficiency in the street lighting if the efficiency in each stage can easily achieve the maximum efficiency in overall system development. The first one in this area, is to choose light emitting diode (LED) technology, instead of sodium vapor lamp and compact fluorescent lamp (CFL), because it is the best solution since it offers benefits like power saving and long life. The second solution is the most revolutionary, it uses a sensor combination to control and guarantee the desired system parameters; the information is transferred point by point using ZigBee transmitters and receivers and is sent to a control terminal used to check the state of the street lamps and to take appropriate measures in case of failure. Finally, the third possibility would be the use of renewable energy sources rather than conventional power sources with a positive effect on the all environment issues. The Solar energy is the most important resource in this field to achieve the maximum efficiency. Street light control system is a centralized system which control and monitor status of the individual street lamp. Lights are switched to ON/OFF automatically based on PIR and LDR status. Status information stored in the PIC

controller and also monitored over all status in control base station via Zigbee communication channel, LED has been the best potential light source for the next-generation lighting as it has many advantages such as high efficiency, long life, high reliability, and low power consumption[1].

II. LITERATURE REVIEW

Literature review is an assignment of previous task done by some authors and collection of information or data from research papers published in journals to progress our task. It is a way through which we can find new ideas, concept. There are lot of literatures published before on the same task; some papers are taken into consideration from which idea of the project is taken.

B. K. Subramanyam1 et al. [2], worked on intelligent wireless street light control and monitoring system, which integrates new technologies, offering ease of maintenance and energy savings. Using solar panel at the lamp post By using LDR it is possible to save some more power and energy, and also we can monitored and controlled the street lights using GUI application, which shows the status of the lights in street or highway lighting systems.

P. Nithya et al. [3], in their work on Design of Wireless Framework for Energy Efficient Street Light Automation suggested an Intelligent management of the lamp posts by sending data to a central station by ZigBee wireless communication. With the suggested system,

maintenance can be easily and efficiently planned from the central station, allowing additional savings.

Srikanth M et al. [4], in their work on ZigBee Based Remote Control Automatic Street Light System. This streetlight control system helps in energy savings, detection of faulty lights and maintenance time and increase in life span of system.

Anila Devi Y et al.[5], worked on GSM Based Remote Control System of High Efficiency Intelligent Street Lighting System Using AZigbee Network of Devices and Sensor. New intelligent and smart street light system is designed with wireless technology for maintenance and network of sensors for controlling. In which, they used high efficiency LED lamp which consumes less energy with high life time and which are supplied with renewable energy of solar panels.

Soyoung Hwang et al.[6], remote monitoring and controlling system based on ZigBee networks. Real-time remote monitoring is implemented with JMF which is a multimedia extension API of Java.

Richu Sam Alex et al.[7] This reduce the power consumption of the street lighting system about 20-35 % compared to conventional design. This system is fully automated and is using ZIGBEE so that the control station can analyze all the performance of the system.

R. Kavitha1 et al.[8] Traffic Signal lights. Depending on the amount of traffic in a particular direction, necessary controlling actions could be taken. Also emergency vehicles

and VIP convoys can be passed efficiently. Moreover, attempts can be made to ensure that the complete system is self-sufficient on nonconventional energy resources like solar power.

HARIHARAN A et al.[9] The system performance including the throughput and the transmission time are also analyzed. It is investigated that high transmission power causes neighbor channel interference, and that the throughput improvement decreases as the transmission Power increases various street light control systems and analyzed its characteristics and requirements, especially for communication characteristics. This gives better understanding about the controller and made us realize the power of the controller.

III. PROPOSED SYSTEM

The proposed system is to design new street light control system that is reliable and cost effective by using Zigbee communication system technique, from the coupling interface to the power management, from the type of microprocessor to the Zigbee transceiver, considering their mutual influence, too. Lighting system that uses an RS232 interface done for the base station control unit. In this paper, we present our system, which is able to integrate all the latest technologies in order to achieve a high efficiency hybrid intelligent street lighting system. Fig. 1 shows schematic of proposed Intelligent Street Lighting system.

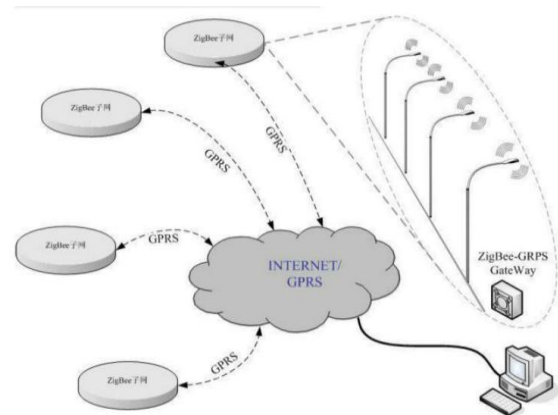

Figure 1: Proposed system View

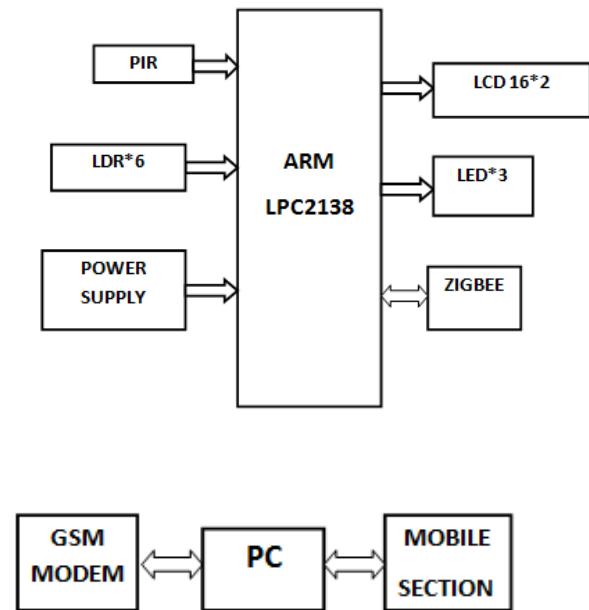

Figure 2: Proposed system Block Diagram

A. Block Diagram Description

a) Liquid Crystal Display

LCD is used in a project to visualize the output of the application. We have used 16x2 LCD which indicates 16 columns and 2 rows. So, we can write 16 characters in each line. So, total 32 characters we can display on 16x2 LCD.

LCD can also be used in a project to check the output of different modules interfaced with the microcontroller. Thus LCD plays a vital role in a project to see the output and to debug the system module wise in case of system failure in order to rectify the problem.

b) RS 232

RS 232 IC is a driver IC to convert the μC TTL logic (0-5) to the RS 232 logic (+/-9v). Many devices today work on RS 232 logic such as PC, GSM modem, GPS etc. so in order to communicate with such devices we have to bring the logic levels to the 232 logic (+/-9v).

c) PIR Sensor

This module can detect infrared rays emanated from a moving human body in a specific area. This module fundamentally detects a change of infrared energy. This module does not only detect a moving human body but also other heat sources similar to human temperature. 2. This module can't detect the presence of a human body if it does not move. 3. This module detects a change of infrared rays through the Fresnel lens. Detection areas and range depend on its surface condition. 4. To prevent malfunctions, operational failure or any deterioration of its characteristics, do not use this module in the following, or similar, conditions. In rapid environmental temperature changes. In strong shock or vibration. In high humidity and temperature. Unit troubles resulting from misuse, inappropriate handling or storage are not the manufacturer's responsibility.

d) RF Tx-Rx(ZIGBEE)

In the wireless world, the names Bluetooth and WiFi have become household names in recent years. They quickly find applications amongst others in mobile computing and mobile phones. ZigBee is the result of the demand from industry and consumer for wireless applications that demand lower data rates, longer battery life, simple design, shorter range and low cost solutions.

ZigBee Applications

ZigBee technology is based on the IEEE 802.15.4 industry standard. It incorporates the standard, adding the logical network, security and software to it. It supports up to 3 network topologies namely star, mesh and cluster tree. Developers need only have to focus on application while the MCU/microprocessor/RF transceiver makers and ZigBee Alliance take care of the RF transmitter, RF receiver, RF channel and its protocol.

e) Light Sensor

Photo resistors or Light Dependent Resistors (LDR) which change resistance according to light intensity. Normally the resistance of a photo resistor (LDR) decreases with increasing intensity of light falling on it. Photomultiplier tubes containing photocathodes which emit electrons when illuminated, the electrons are then amplified by a chain of dynodes.

f) Control Station

The base control station is the hub of the system since it allows the visualization of the entire lighting system. The transmission system consists of a ZigBee device that receives information on the state of the lamps and sends it to a terminal. The processing unit consists of a terminal with a serial Universal Asynchronous Receiver-Transmitter (UART) interface which receives information about the state of the lamps provided by a ZigBee device. The terminal is required for a graphical display of the results. Moreover, data on lamps' operation are associated with the lamp address; consequently, all faults are easily identified. Pressing the button "Power Consumption Data," a second window appears where power consumption and working time of any lamp are given. The program is also equipped with a management system that acts in case of no communication from the lamp posts well explained in Section III-E after the description of the entire system.

g) Control Software flow Chart

The sensors transfer the collected information to a controller which runs the software to analyze the system. Fig. 3 shows the control software flowchart. After the initial setting, the system is controlled by the light sensor which activates the microcontroller only if the sunlight illumination is lower than a fixed threshold. In this case, the system reads the state of the emergency button, and switches on the

lamp if this is activated. The same happens in case of a vehicle or a pedestrian.

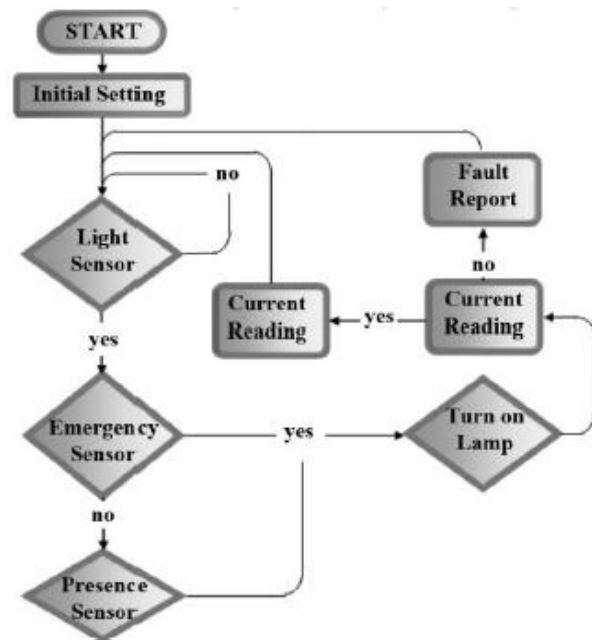

Figure 3: Control software flowchart

IV. CONCLUSION

This project describes an intelligent street lighting system using LED supplied by solar energy and with a control system for efficient management. This features switching ON the lights only when necessary increasing the energy saving and Lamps lifetime. The wireless nature of the control system using ZigBee offers very less maintenance and flexible, extendable and fully adaptable user needs in rural and urban areas. The simplicity of ZigBee, the reliability of electronic components, the feature of the sensor network, the processing speed, the reduced costs, and the ease of installation are the features that characterize the proposed system, which presents itself as an interesting engineering and

commercial solution as the comparison with other technologies.

REFERENCES

[1] Hariharan A, Kirubakaran J, Seethapathi M, "High Efficiency Hybrid Intelligent Street Lighting Using A Zigbee Network And Sensors", *International Journal of Soft Computing and Artificial Intelligence*, Volume-2, Issue-1, May-2014.

[2] B. K. Subramanyam, K. Bhaskar Reddy, P. Ajay Kumar Reddy, "Design and Development of Intelligent Wireless Street Light Control and Monitoring System Along With GUI", *International Journal of Engineering Research and Applications (IJERA)* Vol. 3, Issue 4, Jul- Aug 2013, pp.2115-2119.

[3] P.Nithya, N.Kayalvizhi, "Design of Wireless Framework for Energy Efficient Street Light Automation", *International Journal of Innovative Research in Computer and Communication Engineering (An ISO 3297: 2007 Certified Organization)* Vol.2, Special Issue 1, March 2014

[4] Srikanth MI, Sudhakar K N, "ZigBee Based Remote Control Automatic Street Light System" P.P 2321 - 3361, *IJESC* June 2014

[5] Anila Devi Y, V. Jaya Prakash, "GSM Based Remote Control System of High Efficiency Intelligent Street Lighting System Using A Zigbee Network of Devices and Sensor" *International Journal of Science and Research (IJSR)* P.P 2319-7064.

[6] Soyoung Hwang and Donghui Yu, "Remote Monitoring and Controlling System Based on ZigBee Networks" *International Journal of Software Engineering and Its Applications* Vol. 6, No. 3, July, 2012.

[7] Richu Sam Alex, R NarcissStarbell "Energy Efficient Intelligent Street Lighting System Using ZIGBEE and Sensors", *International Journal of Engineering and Advanced Technology (IJEAT)*, P.P2249 – 8958, Volume-3, Issue-4, April 2014.

[8] R. Kavitha1, N. Thiyagarajan, "Distributed Intelligent Street Lamp Monitoring and Control System Based on

Zigbee" *International Journal of Science and Research (IJSR)* P.P 2319-7064

[9] Hariharan A, Kirubakaran J, 3seethapathi M "High Efficiency Hybrid In Telligent Street Lighting Using AZigbee Network And Sensors" *International Journal Of Soft Computing And Artificial Intelligence*, 2321- 4040, Volume-2, Issue-1, May-2014