

A Survey on Rectifier for PE energy harvesting to maximize the potency transfer from the transducer to the load

MR .K. VIJAY¹, MR.PRADEEP KONDAPALLI ²& B.V.R.GOWRI³

¹PG Scholar Dept. of ECE in Baba Institute of Technology and Sciences,
Visakhapatnam, Andhra Pradesh, India.

²Associate professor Dept. of ECE in Baba Institute of Technology and Sciences,
Visakhapatnam, Andhra Pradesh, India.

³Assistant Professor Dept. of ECE in Baba Institute of Technology and Sciences,
Visakhapatnam, Andhra Pradesh, India.

ABSTRACT

This paper presents a self-powered rectifier for piezoelectric energy harvesting applications, and the key conception of the proposed system is to reset the transducer capacitor at optimal instants to maximize the extracted potency. The proposed rectifier consists of two switches and two active diodes. The switches discharge the transducer capacitor at optimal instants two times for every cycle. The active diodes are predicated on op-amps with a preset dc offset, which reduces the voltage drop and the leakage current and eschews instability. In advisement, the controller for the proposed rectifier is simple to reduce the circuit involution and the potency dissipation. The proposed rectifier was designed and fabricated in 0.18- μm CMOS technology. Quantified results designate that it achieves high power efficiency and the amount of potency extracted by the proposed rectifier is more astronomically immense when compared with the conventional rectifiers. The proposed rectifier does not require any off chip components to enable a full chip integration.

Key words: - Active Rectifier, High Efficiency Rectifier, op-Amp-Based Active-Diodes, Piezoelectric Cantilever, Piezoelectric Energy Harvesting, Synchronized Switch Harvesting On Inductor ,Piezo Electric, Energy Harvesting, Dc Offset, Symmetrical Slew Rate, Class-Ab Op-Amp, Self-Powered Rectifier.

1. INTRODUCTION

In the recent past years many researchers have been working on the energy harvesting. Abstraction of batteries is very utilizable in many applications such as wireless sensor

networks where transmuted of batteries is arduous and costly. Energy harvesting has given a solution for these applications where supersession of batteries is impractical. Piezoelectric energy (PE) harvesting

systems offer efficacious high energy ranging from 10 to several 100's of $\mu\text{w}/\text{cm}^3$. There are several full bridge (FB) rectifiers proposed for PE harvesting systems to maximize the extracted power and these are divided into three types – Conventional Process, Synchronized Switch Process, and Synchronized Switch Harvesting on Inductor (SSHI) . The main aim of the Conventional process is to reduce the voltage drop across the diodes of the rectifier. The most commonly used scheme for this approach uses active diodes predicated on cross-coupled MOSFETs. The main drawback of this method is that the offset of the comparators which causes leakage and oscillations results in incremented loss of potency. Op-Amp predicated active diodes can evade this quandary. Synchronized Switch process is predicated on switching that discharges the internal capacitance at optimal instances of time. This method utilizes a synchronized switch to discharge the capacitor or reset the capacitor voltage at required time. the Switch is in parallel with the internal capacitor and placed across the terminal of the transducer. SSHI method recycles the stored energy across the capacitor by inverting the polarity of the capacitor at zero crossing points of the transducer current by

the additament of an inductor in series with a synchronized switch. The voltage across the capacitor transmutes the polarity when the synchronized switch is closed due to the resonance of the LC network composed by the internal capacitor and the inductor that integrated in series with the synchronized switch. The drawback with this method is the desideratum of sizably voluminous inductor ($>20\mu\text{H}$) occupies astronomically immense place which makes the circuit involute and additionally increases the cost of the circuit .

2. PROPOSED RECTIFIER WITH AUTOMATIC CAPACITOR RESET

Fig. 3 shows the circuit diagram of the proposed rectifier, which consists of two active diodes, D1 and D2, and two switches, SW1 and SW2. The topology of the proposed rectifier is identical to the conventional FB rectifier shown in Fig. 1 except replacement of two diodes on the left branch by two switches. The two switches reset (discharge) transducer capacitor CP at the zero crossing point of the transducer current. Detailed operation and implementation of the proposed rectifier circuit are described in the following.

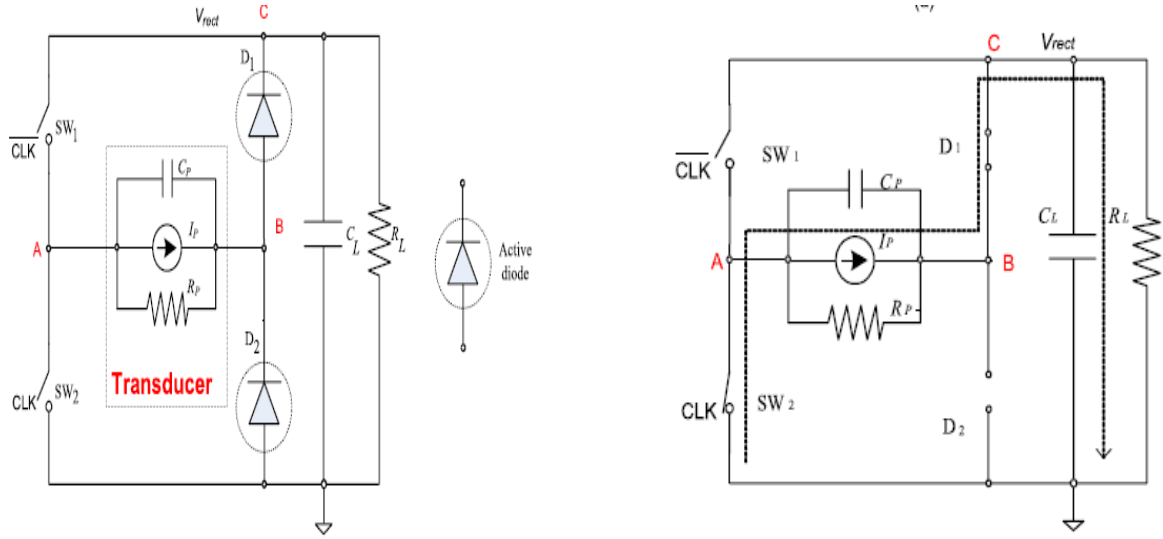
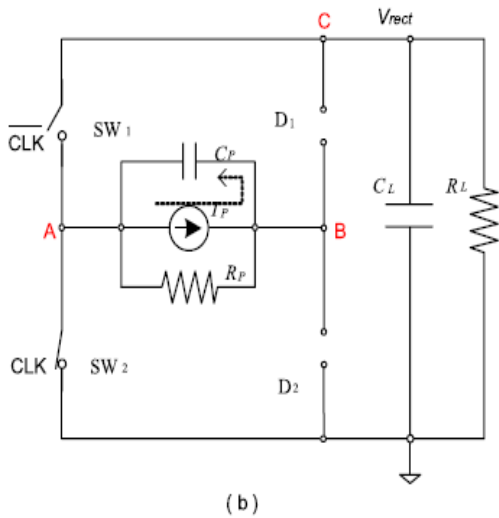
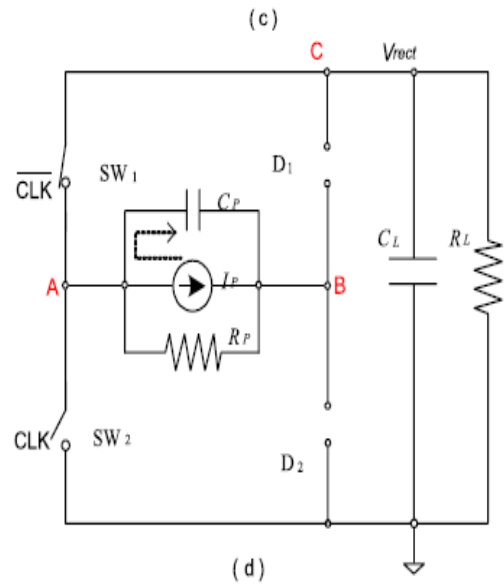
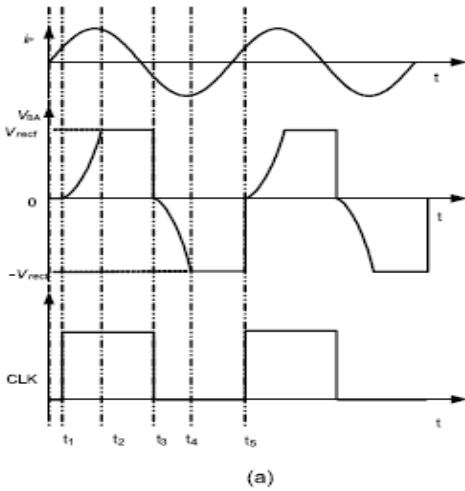

Fig. 3. Circuit diagram of the proposed rectifier.



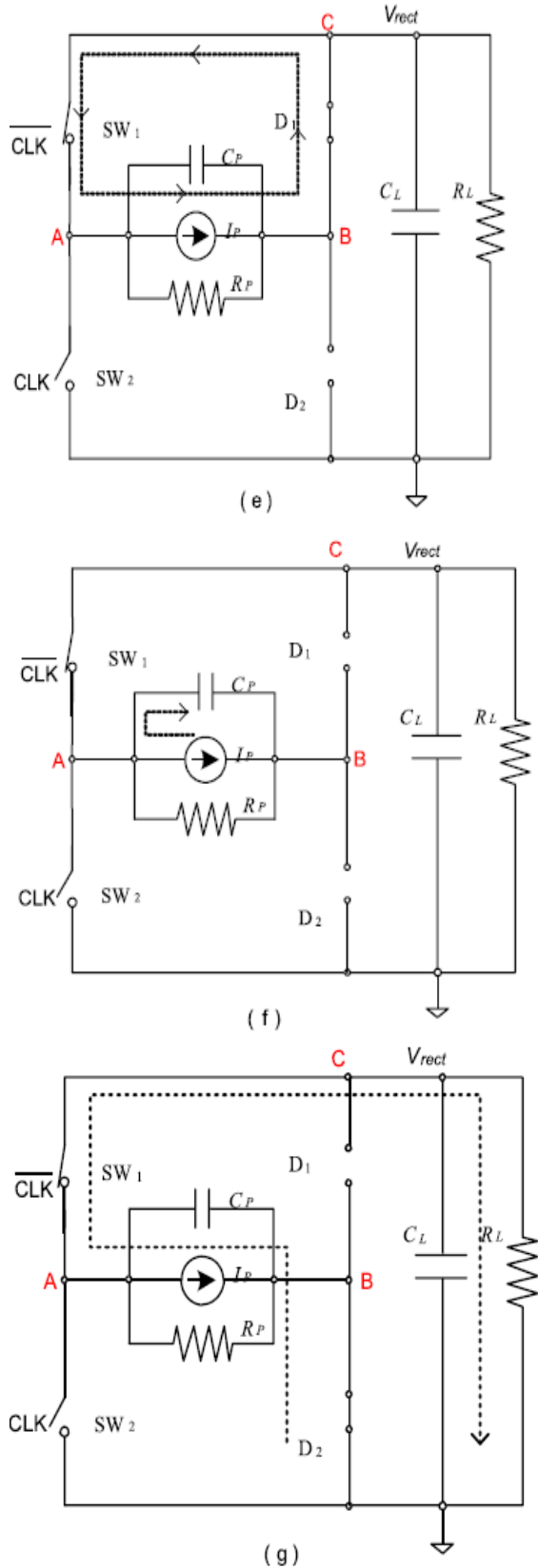

Fig. 4. Operation of the proposed rectifier circuit. (a) Rectifier voltage waveforms. (b) Operation for $t_1 < t < t_2$. (c) Operation for $t_2 < t < t_3$. (d) Slightly after $t_3 + \Delta t$ (transient state). (e) Slightly after $t_3 + 2\Delta t$ (transient state). (f) Operation for $t_3 < t < t_4$. (g) Operation for $t_4 < t < t_5$.

3. IMPLEMENTATION

3.1 Implementation of the Proposed Rectifier:

Diode D₁ is realized with a comparator-predicated active-diode, COM1 and M1, and Diode D₂ with COM2 + M2. Diode D₁ should be turned on: 1) when the transducer current flows into the load, when the reset loop is engendered, For both cases, the negative input of the COM1 is higher than the positive input. Then, output G1 of the comparator becomes low to conduct D₁. Similarly, diode D₂ conducts twice per cycle under the comparator output G2 at high. The digital control block utilizes the two signals G1 and G2 to detect the zero crossing point of the transducer current and engenders the CLK.

A dc-offset of a comparator-predicated active-diode degrades the performance. Consider the rectifier is in the state in which the transducer distributes power to the load. As the transducer current crosses over zero and becomes negative, transducer capacitor

CP commences to discharge and VBA becomes more minuscule than Vrect. Suppose there is a negative offset voltage at the positive input of comparator COM1. Diode D1 is turned off without the offset, and the rectifier transits to the next state. However, the offset obviates the diode from being turned off, and the rectifier remains in the same state. As VBA is more minuscule than Vrect, while D1 and SW2 being turned on, the current flows in the inversion direction, i.e., from the load to the transducer, to cause a leakage of the charge stored at capacitor CL.

3.2 Implementation of the Digital Control Block

The clock signal engenderer is the most critical part of the circuit, because it directly affects the operation of the rectifier. Several techniques were investigated for clock signal generation, but they are often perplex adopt several capacitors and require external tuning, while uses four passive diodes, three capacitors, and one comparator.. The circuit consists of two sub-blocks, a clock engenderer and a dead time control block. The CLK signal is engendered utilizing two D flip-flops from signals G1 and G2. To avert from simultaneous turning on of the two switches, M3 and M4 during transition, a dead time control block engenders two

separate clocks, PCLK for M4 and NCLK for M3. The dead time control block ascertains that M3, and M4 are never turned on concurrently.

4. EXPERIMENTAL RESULTS

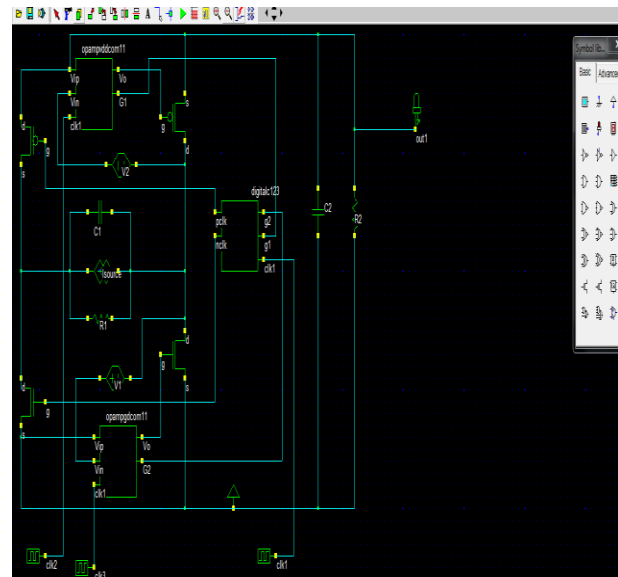

Fig 1 Schematic output

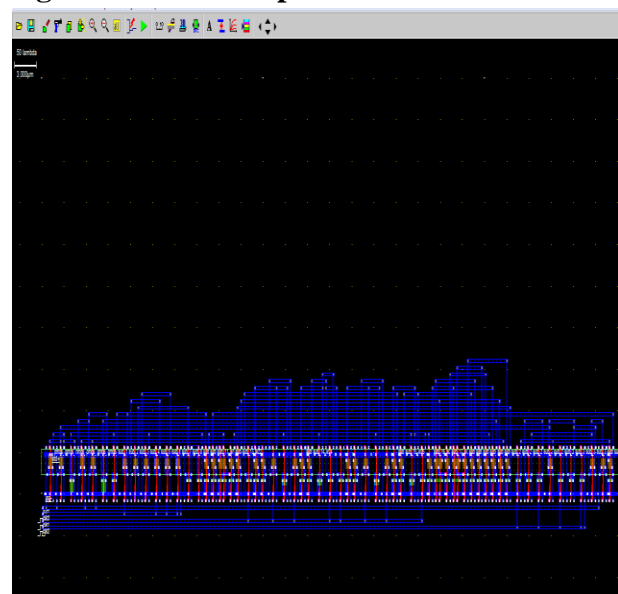

Fig 2 Layout output

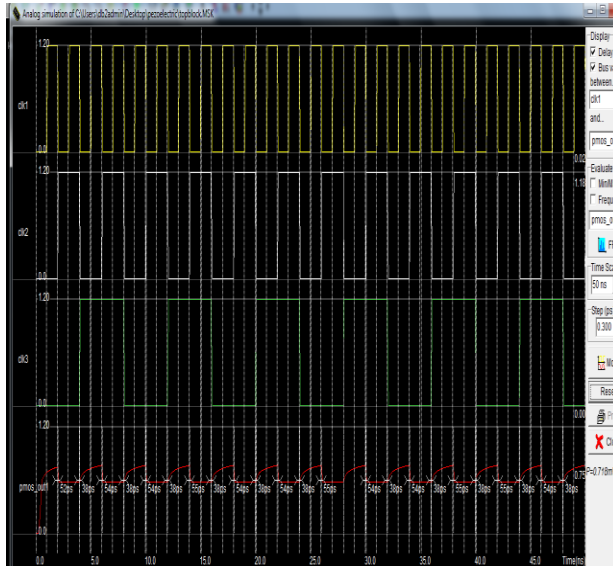

Fig 3 Layout simulation output

5. CONCLUSION

A rectifier for PE energy harvesting was presented in this paper. Rectifiers play a critical role for PE energy harvesting to maximize the potency transfer from the transducer to the load. Two major sources of loss for rectifiers for PE energy harvesting are the energy waste during the transducer capacitor charging/discharging and the diode voltage drop. A synchronized switch is an efficacious scheme to reduce the waste associated with the capacitor charging/discharging process. Subsisting methods for synchronized switches have several drawbacks such as involute control circuitry, external supply voltages, and astronomically immense size inductors. The proposed method for automatic resetting of the capacitor intends to address the

drawbacks. The control circuitry for the proposed method is simple, and it does not require an external supply voltage nor an inductor. Active diodes were intensively investigated to reduce the diode voltage drop. Active diodes are often predicated on comparators, but they face offset and oscillation quandaries to cause lower efficiency. The proposed rectifier adopts active diodes predicated on op-amps with a built-in offset abrogation, which address the shortcomings of comparator-predicated active diodes. The proposed rectifier was designed and fabricated in 0.18- μm CMOS processing technology. Simulation and quantification results are consistent with analytical results. The Quantification results designate that the proposed rectifier can increment the extracted power by up to 350% when compared with a conventional FB rectifier, and achieves the maximum efficiency of 91.2%. Albeit it is arduous to make a fair comparison, the proposed rectifier performs better than competing rectifiers in many aspects.

6. REFERENCE

[1] X. D. Do, Y. H. Ko, H. H. Nguyen, H. B. Le, and S. G. Lee, "An efficient parallel SSHI rectifier for piezoelectric energy scavenging systems," in Proc. IEEE Int.

Conf. Adv. Commun. Technol., 2011, pp. 1394–1397.

[2] Y. Ramadass and A. Chandrakasan, “An efficient piezoelectric energy harvesting interface circuit using a bias-flip rectifier and share inductor,” *IEEE J. Solid-State Circuit*, vol. 45, no. 1, pp. 189–204, Jan. 2010.

[3] Y. K. Ramadass, “Energy processing circuit for low-power applications,” Ph.D. dissertation, Dept. Electr. Eng. Comput. Sci., Massachusetts Inst. Technology, Cambridge, MA, USA, Jun. 2009.

[4] Y. H. Lam, W. H. Ki, and C. Y. Tsui, “Integrated low-loss CMOS active rectifier for wirelessly powered devices,” *IEEE Trans. Circuit Syst. II*, vol. 53, no. 12, pp. 1378–1382, Dec. 2006.

[5] S. Guo and H. Lee, “An efficiency-enhanced CMOS rectifier with unbalanced-bias comparators for transcutaneous-power high-current implants,” *IEEE J. Solid-State Circuit*, vol. 44, no. 6, pp. 1796–1804, Jun. 2009.

[6] E. Dallage et al., “Active self supplied AC-DC converter for piezoelectric energy scavenging systems with supply independent bias,” in *Proc. IEEE Int. Symp. Circuit Syst. Conf.*, May 2008, pp. 1448–1451.

[7] N. J. Guilar, R. Amirtharajah, and P. J. Hurst, “A fully-wave rectifier for interfacing

with multi-phase piezoelectric energy harvesters,” in *IEEE ISSCC Dig. Tech. Papers*, Feb. 2008, pp. 302–304.

[8] G. K. Ottman, H. F. Hofmann, A. C. Bhatt, and G. A. Lesieutre, “Adaptive piezoelectric harvesting circuit for wireless remote power supply,” *IEEE Trans. Power Electron.*, vol. 17, no. 5, pp. 669–676, Sep. 2002.

[9] Y. Sun, N. H. Hieu, C. J. Jeong, and S. G. Lee, “An integrated highperformance active rectifier for piezoelectric vibration energy harvesting systems,” *IEEE Trans. Power Electron. Lett.*, vol. 27, no. 2, pp. 623–627, Feb. 2012.

[10] N. Krihely and S. B. Yaakov, “Self-contained resonant rectifier for piezoelectric sources under variable mechanical excitation,” *IEEE Trans. Power Electron.*, vol. 26, no. 2, pp. 612–621, Feb. 2011.

Authors Profiles



Mr .K. Vijay is a **PG Scholar** and **B.Tech** in Baba Institute of Technology And Sciences, Visakhapatnam, Andhra Pradesh, India.

Mail id: - vijaybitsvizag@gmail.com



Mr. PRADEEP KONDAPALLI, B-Tech, M-Tech is an Associate professor in ECE Department of BITS, Vizag. He has a dedicated teaching experience of 8 years. He did his masters (MTech) from JNTU University Campus College, Kakinada and bachelors (BTech) from SITM College. His previous eight years working experience in various colleges like AGCET, SSIET, SVKRCET & SITM in costal districts of Andhra. He began his career by joining as assistant professor in AGCET, Tadepalligudem worked for 2 years and another 2 years at Sri Sarathi Engineering college, Nuzvid as an Assistant Professor later he associated with Svkr Engineering college, Bhimavaram as head of the department for 3 years & one year at Sarada Engineering college as head of the department and also acted as co-ordinator for polytechnic. Now he joined his hands with BITS since Nov 2012. He has a credit of publishing one International Journal titled "Color-Texture Features Based Image Retrieval Using Structure

Wavelet" selected in International conference by IJERT. He is interested in the fields of embedded systems, Communications & computer networks. He acted as College committee coordinator for ISO & NBA, attended workshops & faculty development programs like NPTEL, ISTE.

Mail id: - pradeepbitsvizag@gmail.com



B.V.R.Gowri B-Tech M-Tech., is an Assistant Professor in the Department of ECE at "Baba institute of technology and sciences" graduated in B-Tech Electronics And Communication Engineering from Jawaharlal Nehru Technological University, Kakinada in 2009. She has over 4 years of experience in teaching career. Her teaching area is in Linear IC Applications, Analog & Digital Communications, Digital IC Applications, Electrical & electronics, Control Systems and Electronic Circuit Analysis. She organized and attended various Technical Events and workshops in teaching career.

Email Id :- gowri.bobbili@bitsvizag.com