

Study of Microstrip Patch Antenna for Communication System

^aDr. Sumit Kumar Gupta ^b Nipun Sharma ^cHarish kumar jangam

^a Assistant Professor Parishkar College of Global Excellence ,Jaipur

^bResearch scholar Sunrise University , jaipur

^c Assistant Professor Parishkar College of Global Excellence ,Jaipur

Email:Sumit_bharatpur@rediffmail.com

Abstract :

This article presents an overview of the microstrip patch antenna and its design techniques. Basically a microstrip patch antenna comprises of a trace of copper or any other metal of any geometry on one side of a standard printed circuit board substrate with other side grounded. The antenna is fed using various feeding techniques like coaxial, strip line, aperture coupling or proximity coupling techniques. The working principle and the radiation mechanism have also been described. The microstrip patch antenna is widely used military, industrial and commercial sectors.

Introduction

In its most basic form, a Microstrip patch antenna consists of a radiating patch on one side of a dielectric substrate which has a ground plane on the other side as shown in Figure 1. The patch is generally made of conducting material such as copper or gold and can take any possible shape. The radiating patch and the feed lines are usually photo etched on the dielectric substrate

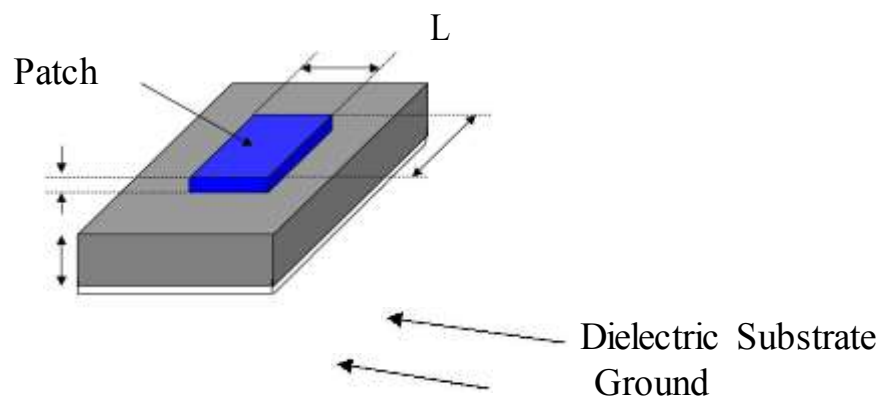

Figure 1 Structure of a Microstrip Patch Antenna

In order to simplify analysis and performance prediction, the patch is generally

square, rectangular, circular, triangular, elliptical or some other common shape as shown in Figure 2. For a rectangular patch, the length L of the patch is usually $0.3333\lambda_o < L < 0.5\lambda_o$, where λ_o is the free-space wavelength. The patch is selected to be very thin such that $t \ll \lambda_o$ (where t is the patch thickness). The height h of the dielectric substrate is usually $0.003 \lambda_o \leq h \leq 0.05\lambda_o$. The dielectric constant of the substrate (ϵ_r) is typically in the range $2.2 \leq \epsilon_r \leq 12$.

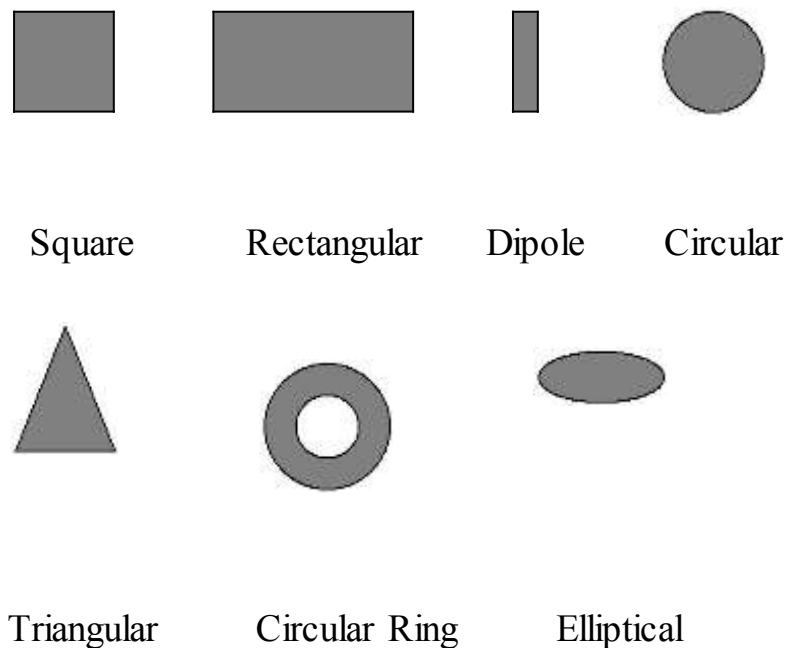

Figure 2 Common shapes of microstrip patch elements

Microstrip patch antennas radiate primarily because of the fringing fields between the patch edge and the ground plane. For good antenna performance, a thick dielectric substrate having a low dielectric constant is desirable since this provides better efficiency, larger bandwidth and better radiation [5]. However, such a configuration leads to a larger antenna size. In order to design a compact Microstrip patch antenna, higher dielectric constants must be used which are less efficient and result in narrower bandwidth. Hence a compromise must be reached between antenna dimensions and antenna performance.

Advantages and Disadvantages

Microstrip patch antennas are increasing in popularity for use in wireless applications due to their low-profile structure. Therefore they are extremely compatible for embedded antennas in handheld wireless devices such as cellular phones, pagers etc... The telemetry and communication antennas on missiles need to be thin and conformal and are often Microstrip patch antennas. Another area where they have been used successfully is in Satellite communication. Some of their principal advantages discussed by [5] and Kumar and Ray [9] are given below:

- Light weight and low volume.
- Low profile planar configuration which can be easily made conformal to host surface.
- Low fabrication cost, hence can be manufactured in large quantities.
- Supports both, linear as well as circular polarization.
- Can be easily integrated with microwave integrated circuits (MICs).
- Capable of dual and triple frequency operations.
- Mechanically robust when mounted on rigid surfaces.

Microstrip patch antennas suffer from a number of disadvantages as compared to

conventional antennas. Some of their major disadvantages discussed by [9] and Garg et al [10] are given below:

- Narrow bandwidth
- Low efficiency
- Low Gain
- Extraneous radiation from feeds and junctions
- Poor end fire radiator except tapered slot antennas

- Low power handling capacity.
- Surface wave excitation

Microstrip patch antennas have a very high antenna quality factor (Q). Q represents the

losses associated with the antenna and a large Q leads to narrow bandwidth and low efficiency. Q can be reduced by increasing the thickness of the dielectric substrate. But as the thickness increases, an increasing fraction of the total power delivered by the source goes into a surface wave. This surface wave contribution can be counted as an unwanted power loss since it is ultimately scattered at the dielectric bends and causes degradation of the antenna characteristics. However, surface waves can be minimized by use of photonic bandgap structures as discussed by Qian et al [11]. Other problems such as lower gain and lower power handling capacity can be overcome by using an array configuration for the elements

Feed Techniques

Microstrip patch antennas can be fed by a variety of methods. These methods can be classified into two categories- contacting and non-contacting. In the contacting method, the RF power is fed directly to the radiating patch using a connecting element such as a microstrip line. In the non-contacting scheme, electromagnetic field coupling is done to transfer power between the microstrip line and the radiating patch [5]. The four most popular feed techniques used are the microstrip line, coaxial probe (both contacting schemes), aperture coupling and proximity coupling (both non-contacting schemes).

Microstrip Line Feed

In this type of feed technique, a conducting strip is connected directly to the edge of the microstrip patch as shown in Figure 3. The conducting strip is smaller in width as compared to the patch and this kind of feed arrangement has the advantage that the feed can be etched on the same substrate to provide a planar structure. The purpose of the inset cut in the patch is to match the impedance of the feed line to the patch without the need for any additional matching element. This is achieved by properly controlling the inset position. Hence this is an easy feeding scheme, since it provides ease of fabrication and simplicity in modeling as well as impedance matching. However as the thickness of the dielectric substrate being

used, increases, surface waves and spurious feed radiation also increases, which hampers the bandwidth of the antenna [5]. The feed radiation also leads to undesired cross polarized radiation.

Coaxial Feed

The Coaxial feed or probe feed is a very common technique used for feeding Microstrip patch antennas. As seen from Figure 4, the inner conductor of the coaxial connector extends through the dielectric and is soldered to the radiating patch, while the outer conductor is connected to the ground plane.

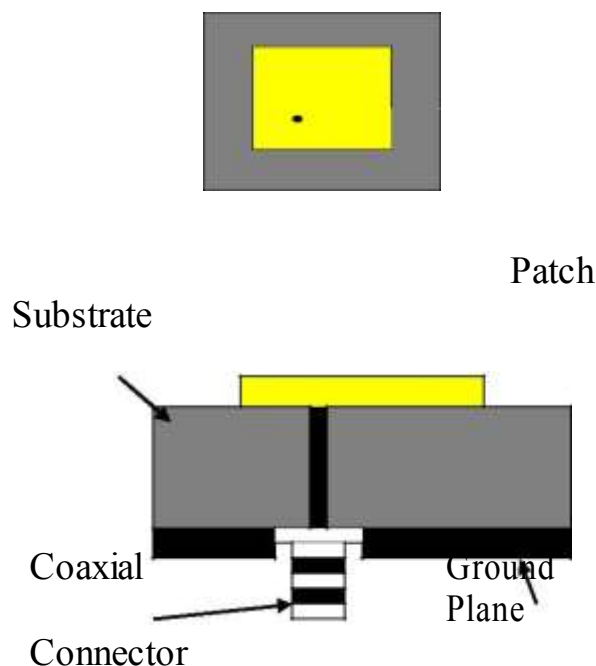
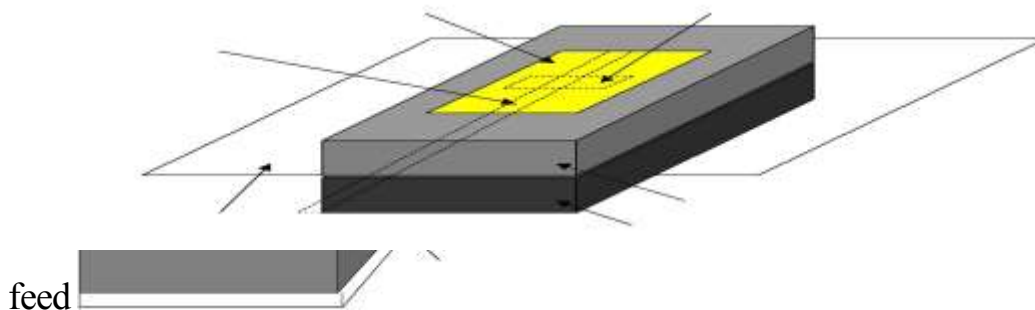

Figure 4 Probe fed Rectangular Microstrip Patch Antenna

The main advantage of this type of feeding scheme is that the feed can be placed at any desired location inside the patch in order to match with its input impedance. This feed method is easy to fabricate and has low spurious radiation. However, its major disadvantage is that it provides narrow bandwidth and is difficult to model since a hole has to be drilled in the substrate and the connector protrudes outside the ground plane, thus not making it completely planar for thick substrates ($h > 0.02\lambda_0$). Also, for thicker substrates, the increased probe length makes the input impedance more inductive, leading to matching problems [9]. It is seen above that for a thick dielectric substrate, which provides broad bandwidth, the microstrip line feed and the coaxial feed suffer from numerous disadvantages. The non-contacting feed techniques which have been discussed below, solve these problems.

Aperture Coupled Feed

In this type of feed technique, the radiating patch and the microstrip feed line are separated by the ground plane as shown in Figure 5. Coupling between the patch and the feed line is made through a slot or an aperture in the ground plane.



Substrate 2

Figure 5 Aperture-coupled feed

The coupling aperture is usually centered under the patch, leading to lower cross-polarization due to symmetry of the configuration. The amount of coupling from the feed line to the patch is determined by the shape, size and location of the aperture. Since the ground plane separates the patch and the feed line, spurious radiation is minimized. Generally, a high dielectric material is used for the bottom substrate and a thick, low dielectric constant material is used for the top substrate to optimize radiation from the patch [5]. The major disadvantage of this feed technique is that it is difficult to fabricate due to multiple layers, which also increases the antenna thickness. This feeding scheme also provides narrow bandwidth.

Proximity Coupled Feed

This type of feed technique is also called as the electromagnetic coupling scheme. As shown in Figure 6, two dielectric substrates are used such that the feed line is between the two substrates and the radiating patch is on top of the upper substrate. The main advantage of this feed technique is that it eliminates spurious feed

radiation and provides very high bandwidth (as high as 13%) [5], due to overall increase in the thickness of the microstrip patch antenna. This scheme also provides choices between two different dielectric media, one for the patch and one for the feed line to optimize the individual performances.

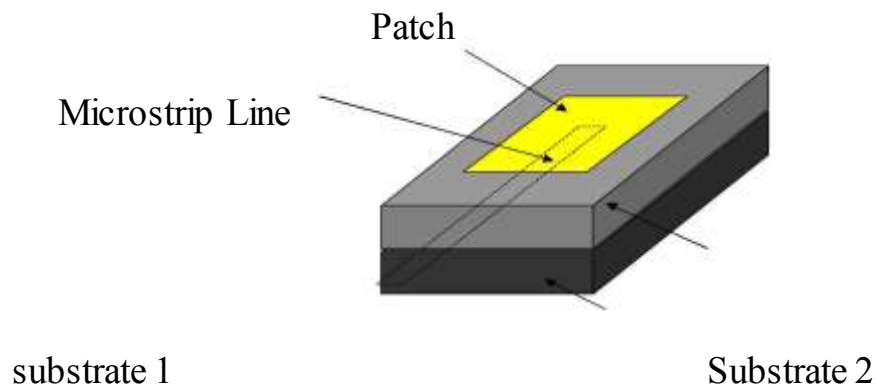

Figure 6 Proximity-coupled Feed

Matching can be achieved by controlling the length of the feed line and the width-to-line ratio of the patch. The major disadvantage of this feed scheme is that it is difficult to fabricate because of the two dielectric layers which need proper alignment. Also, there is an increase in the overall thickness of the antenna Table 1 below summarizes the characteristics of the different feed techniques.

Table 1 Comparing the different feed techniques [4]

Characteristics	Microstrip Line Feed	Coaxial Feed	Aperture coupled Feed	Proximity coupled Feed
Spurious feed Radiation	More	More	Less	Minimum
Reliability	Better	Poor due to soldering	Good	Good
Ease of Fabrication	Easy	Soldering and drilling needed	Alignment required	Alignment required
Impedance Matching	Easy	Easy	Easy	Easy
Bandwidth (achieved with Impedance matching)	2-5%	2-5%	2-5%	13%

Methods of Analysis

The most popular models for the analysis of Microstrip patch antennas are the transmission line model, cavity model, and full wave model [5] (which include primarily integral equations/Moment Method). The transmission line model is the simplest of all and it gives good physical insight but it is less accurate. The cavity model is more accurate and gives good physical insight but is complex in nature. The full wave models are extremely accurate, versatile and can treat single elements, finite and infinite arrays, stacked elements, arbitrary shaped elements and coupling. These give less insight as compared to the two models mentioned above and are far more complex in nature.

Transmission Line Model

This model represents the microstrip antenna by two slots of width W and height h , separated by a transmission line of length L . The microstrip is essentially a nonhomogeneous line of two dielectrics, typically the substrate and air.

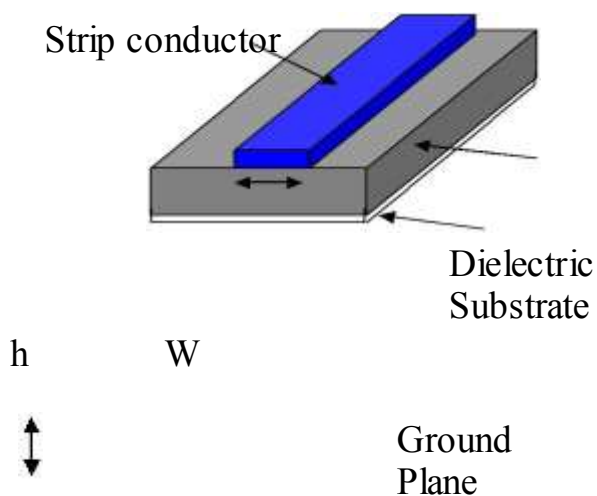

Figure 7 Microstrip Line

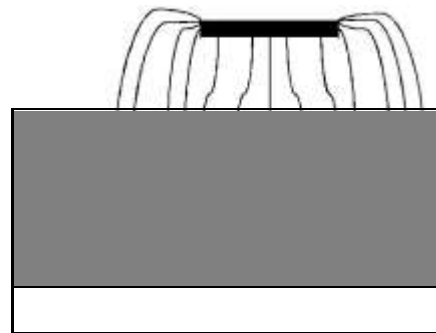

Figure 8 Electric Field Lines

Hence, as seen from Figure 8, most of the electric field lines reside in the substrate and parts of some lines in air. As a result, this transmission line cannot support pure transverse-electric-magnetic (TEM) mode of transmission, since the phase velocities would be different in the air and the substrate. Instead, the dominant mode of propagation would be the quasi-TEM mode. Hence, an effective dielectric constant (ϵ_{eff}) must be obtained in order to account for the fringing and the wave propagation in the line. The value of ϵ_{eff} is slightly less than ϵ_r because the fringing fields around the periphery of the patch are not confined in the dielectric substrate but are also spread in the air as shown in Figure 8 above.

Consider Figure 9 below, which shows a rectangular microstrip patch antenna of length L , width W resting on a substrate of height h . The co-ordinate axis is selected such that the length is along the x direction, width is along the y direction and the height is along the z direction.

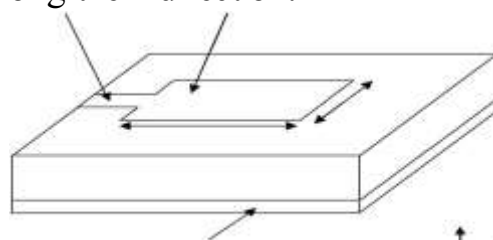
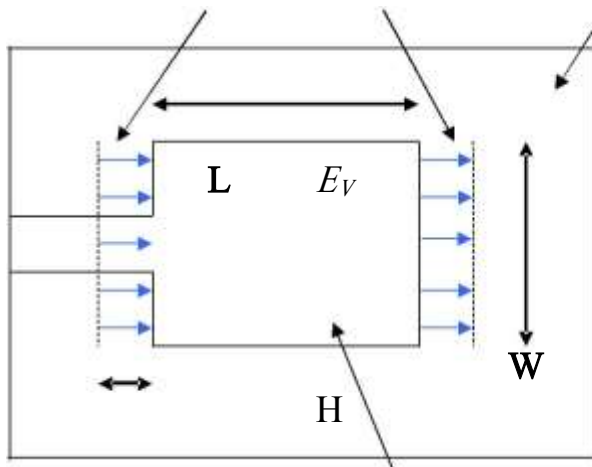

Figure 9 Microstrip Patch Antenna

In order to operate in the fundamental TM_{10} mode, the length of the patch must be slightly less than $\lambda / 2$ where λ is the wavelength in the dielectric medium and is equal to $\lambda_0 / \sqrt{\epsilon_{eff}}$ where λ_0 is the free space wavelength. The TM_{10} mode implies that the field varies one $\lambda / 2$ cycle along the length, and there is no variation along the width of the patch. In the Figure 3.10 shown below, the microstrip patch antenna is represented by two slots, separated by a transmission line of length L and open circuited at both the ends. Along the width of the patch, the voltage is maximum and current is minimum due to the open ends. The fields at the edges can be resolved into normal and tangential components with respect to the ground plane.



ΔL

Patch

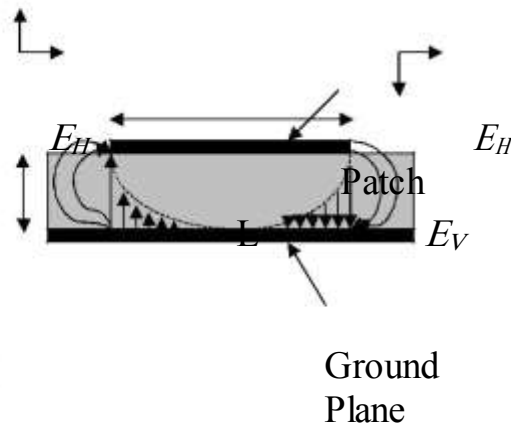

Ground Plane

Figure 10 Top View of Antenna

Figure 11 Side View of Antenna

It is seen from Figure 11 that the normal components of the electric field at the two edges along the width are in opposite directions and thus out of phase since the patch is $\lambda / 2$ long and hence they cancel each other in the broadside direction. The tangential components (seen in Figure 3.11), which are in phase, means that the resulting fields combine to give maximum radiated field normal to the surface of

the structure. Hence the edges along the width can be represented as two radiating slots, which are $\lambda / 2$ apart and excited in phase and radiating in the half space above the ground plane. The fringing fields along the width can be modeled as radiating slots and electrically the patch of the microstrip antenna looks greater than its physical dimensions. The dimensions of the patch along its length have now been extended on each end by a distance ΔL , which is given empirically by Hammerstad [13] as:

Cavity Model

Although the transmission line model discussed in the previous section is easy to use, it has some inherent disadvantages. Specifically, it is useful for patches of rectangular design and it ignores field variations along the radiating edges. These disadvantages can be overcome by using the cavity model. A brief overview of this model is given below.

In this model, the interior region of the dielectric substrate is modeled as a cavity bounded by electric walls on the top and bottom. The basis for this assumption is the following observations for thin substrates ($h \ll \lambda$) [10].

- Since the substrate is thin, the fields in the interior region do not vary much in the z direction, i.e. normal to the patch.
- The electric field is z directed only, and the magnetic field has only the transverse components H_x and H_y in the region bounded by the patch metallization and the ground plane. This observation provides for the electric walls at the top and the bottom.

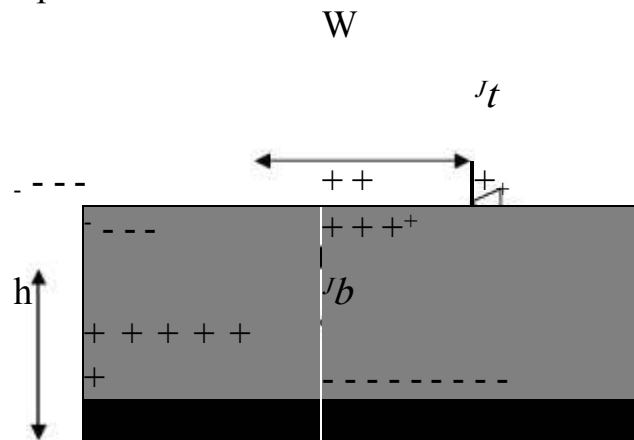

Figure 12 Charge distribution and current density creation on the microstrip patch

Consider Figure 12 shown above. When the microstrip patch is provided power, a charge distribution is seen on the upper and lower surfaces of the patch and at the bottom of the ground plane. This charge distribution is controlled by two mechanisms—an attractive mechanism and a repulsive mechanism as discussed by Richards [16]. The attractive mechanism is between the opposite charges on the bottom side of the patch and the ground plane, which helps in keeping the charge concentration intact at the bottom of the patch. The repulsive mechanism is between the like charges on the bottom surface of the patch, which causes pushing of some charges from the bottom, to the top of the patch. As a result of this charge movement, currents flow at the top and bottom surface of the patch. The cavity model assumes that the height to width ratio (i.e. height of substrate and width of the patch) is very small and as a result of this the attractive mechanism dominates and causes most of the charge concentration and the current to be below the patch surface. Much less current would flow on the top surface of the patch and as the height to width ratio further decreases, the current on the top surface of the patch would be almost equal to zero, which would not allow the creation of any tangential magnetic field components to the patch edges. Hence, the four sidewalls could be modeled as perfectly magnetic conducting surfaces. This implies that the magnetic fields and the electric field distribution beneath the patch would not be disturbed. However, in practice, a finite width to height ratio would be there and this would not make the tangential magnetic fields to be completely zero, but they being very small, the side walls could be approximated to be perfectly magnetic conducting [5].

Conclusions

This article presents a review on microstrip patch antenna. The design and analysis methods of a patch antenna have been discussed. Different shapes of the patch have been used and discussed according to the applications. Although a lot of work has been done on microstrip antenna, still lot has to be done. With the advancement of microwave and millimeter wave technologies, systems are now going towards miniaturization.

Reference

[1] David R. Jackson Jeffery T. Williams Donald R. Wilton “Chapter 9: Antennas II Applied Electromagnetic Laboratory” Department of Electrical and Computer Engineering University of Houston.

[2] www.antenna-theory.com

- [3] <http://www.brainwareknowledgehub.com>
- [4] George Casu, Andrei Kovacs “Design and Implementation of Microstrip Patch Antenna Array “
- [5] James j., and P.S. Hall (Eds), Handbook of microstrip antenna, Peter Peregrinus, London, UK, 1989 microstrip antenna, Peter Peregrinus, London, UK, 1989
- [6] R.Garg, P.Bhartia, I.Bahl, A. Ittipiboon, "Micro strip Antenna Design Handbook", ARTECH HOUSE, Boston2001.
- [7] S.Silver, "Microwave Antenna Theory and Design", McGRAW-HILLBOOK COMPANY,INC, NewYork1949...