

An Active Power Filter Implemented With Stability Analysis of Voltage Source Inverter Using a Predictive Control Scheme

¹Rajender Boini1 , ²Dr.Dharamveer mangal

¹Research scholar, Department of Electrical Engineering, Sunrise university, Alwar,Rajasthan.

²Supervisor, Department of Electrical Engineering, Sunrise university, Alwar, Rajasthan

ABSTRACT

The main aim of project is to reduce the power quality problems in distribution system by using active filter. In this project PV Connected active type power filter is implemented. An active power filter consists of dc link capacitor, grid interfacing voltage source inverter, and filter. The dc voltage is supplied by photovoltaic system which is stored in capacitor. In this project we are using four leg voltage source inverter which converts DC to AC voltage. And the harmonics are eliminated by filter. Predictive controlling scheme use to operate or control the switches of voltage source inverter. All of these functions may be accomplished either individually or simultaneously. And we observed the simulation results by using MATLAB/SIMULINK

Keywords: Power quality, Active Power Filter, Converters, PV Cells, Hybrid systems, Distribution system

I. INTRODUCTION

Modern world technology offers a choice to reduce the burden on non renewable energy sources in meeting load demand to prolong its availability by partially meeting the load demand with renewable power generation. Renewable energy is generally defined as energy that comes from resources which are naturally replenished on a human time scale such as sunlight, wind, rain, tides, waves, and geothermal heat.

However, renewable generations affect the power quality due to its partial availability and non linearity. Since Solar generation plants and wind power generators must be connected to the grid through high-power static PWM converters. And later the power collected in the grid is distributed to small scale industries and for domestic purpose .The quest to improve power quality of the distribution system has introduced active power filter into the system. In this project we are using pv system with active power filter to improve the power quality.

II. POWER QUALITY

Power quality is defined as to maintain the voltage, current and power factor with require levels is known as power quality. Simply we can say quality of

voltage rather than the current or power. Power quality is an issue that is becoming increasingly important to electricity consumers at all levels of usage. Sensitive equipment and non-linear loads are now more commonplace in both the industrial commercial sectors and the domestic environment. Because of this a heightened awareness of power quality is developing amongst electricity users. Occurrences affecting the electricity supply that were once considered acceptable by electricity companies and users are now often considered a problem to the users of everyday equipment. However the harmonic is one of the major factor due to which none of condition is fulfilled in practice. The presence of harmonics, disturbs the waveform shape of voltage and current, and increases the current level and changes the power factor of supply and which in turn creates so many problems.

III. PHOTOVOLTAIC SYSTEM

Converting solar energy into electrical energy by PV installations is the most recognized way to use solar energy. Since solar photovoltaic cells are semiconductor devices, they have a lot in common with processing and production techniques of other semiconductor devices such as computers and memory chips. As it is well known, the requirements for purity and quality control of semiconductor devices are quite large. Solar photovoltaic modules, which are a result of combination of photovoltaic cells to increase their power, are highly reliable, durable and low noise devices to produce electricity. The fuel for the photovoltaic cell is free. The sun is the only resource that is required for the operation of PV systems, and its energy is almost inexhaustible.

IV. PV-HYBRID SYSTEMS

In cases where it is not feasible economically or practically to supply the requisite energy from PV modules other means are used. In most cases the PV system is used in conjunction with a Diesel generator. Such a hybrid system ensures that energy demands are met while fully utilizing the PV supply. A typical hybrid system is shown in Figure.

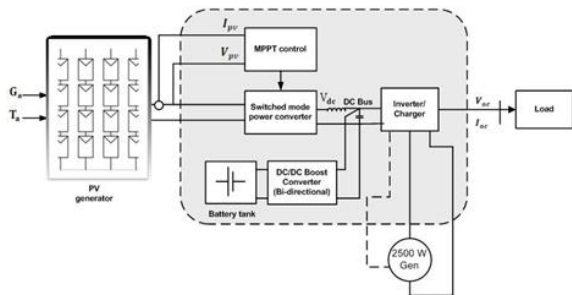

Figure 1: Hybrid stand-alone PV system

V. ACTIVE POWER FILTER

In a modern power system, increasing of loads and nonlinear equipment's have been demanding the compensation of the disturbances caused for them. These non-linear loads may cause poor power factor and high degree of harmonics. Active power filter (APF) can solve problems of harmonic and reactive power simultaneously. APF's consisting of voltage source inverters and a dc capacitor have been researched and developed for improving the power factor and stability of transmission systems. APF have the ability to adjust the amplitude of the synthesized ac voltage of the inverters by means of pulse width modulation or by control of the dc-link voltage, thus drawing either leading or lagging reactive power from the supply. APF's are an up-to-date solution to power quality problems. Shunt APF's allows the compensation of current harmonics and unbalance, together with power factor correction, and can be a much better solution than conventional approach (capacitors and passive filters). The simplest method of eliminating line current harmonics and improving the system power factor is to use passive LC filters. However, bulk passive components, series and parallel resonance and a fixed compensation characteristic are the main drawbacks of passive LC filters.

Harmonic compensations have become increasingly important in power systems due to the widespread use of adjustable-speed drives, arc furnace, switched-mode power Supply, uninterruptible power supply, etc. Harmonics not only Increase the losses but also produce unwanted disturbance to the communication network, more voltage and/or current Stress, etc. Different

mitigation solutions, e.g., passive filter, Active power line conditioner, and also hybrid filter, have been Proposed and used. Recent technological advancement of switching devices and availability of cheaper controlling devices, E.g., DSP-/field-programmable-gate-array-based system, Make active power line conditioner a natural choice to compensate for harmonics. Shunt-type active power filter (APF) is used to eliminate the current harmonics. The dynamic performance of an APF is mainly dependent on how quickly and how accurately the harmonic components are extracted from the load current. Many harmonic extraction Techniques are available, and their responses have been explored. In this project a new concept is proposed that is FBD algorithm in three-phase four-wire shunt active power filter to compensate the harmonics.

In APF design and control, instantaneous reactive power theory was often served as the basis for the calculation of compensation current. In this theory, the mains voltage was assumed to be an ideal source in the calculation process. However, in most of time and most of industry power systems, mains voltage may be unbalanced and/or distorted. Under such scenarios, this theory may not be valid for application.

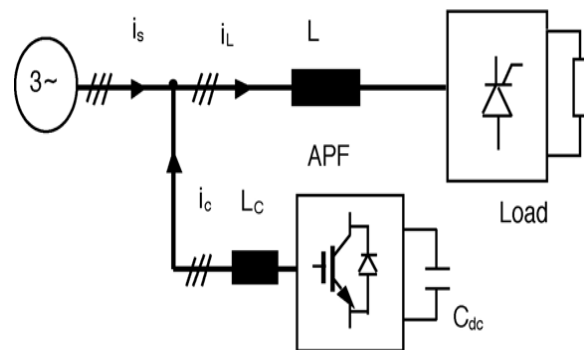

Fig: 2 Block diagram of APF

VI. PROPOSED MODEL

Renewable sources, such as wind and sunlight, are typically used to generate electricity for residential users and small industries. Both types of power generation use ac/ac and dc/ac static PWM converters for voltage conversion and battery banks for long-term energy storage. These converters perform maximum power point tracking to extract the maximum energy possible from wind and sun. The electrical energy consumption behaviour is random and unpredictable, and therefore, it may be single- or three-phase, balanced or unbalanced, and linear or

nonlinear. An active power filter is connected in parallel at the point of common coupling to compensate current harmonics, current unbalance, and reactive power.

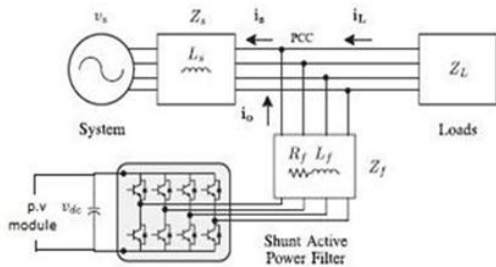

Fig 3. Three-phase equivalent circuit of the proposed shunt active power filter

VII. CONTROLLING SCHEME

The block diagram of the proposed digital predictive current control scheme is shown in Fig. below. This control scheme is basically an optimization algorithm and, therefore, it has to be implemented in a microprocessor. Consequently, the analysis has to be developed using discrete mathematics in order to consider additional restrictions such as time delays and approximations.

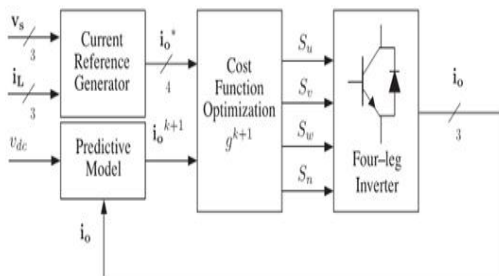

Fig 4 Proposed predictive digital current control block diagram.

VIII. MATLAB/SIMULINK RESULTS

A) EXISTING RESULTS

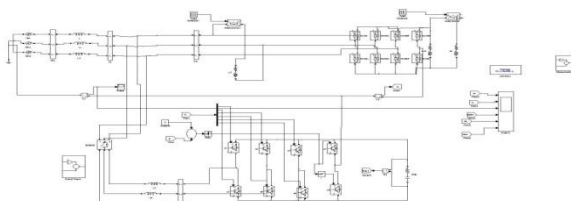

FIG 5 MATLAB/SIMULINK CIRCUIT DIAGRAM OF PROPOSED MODEL

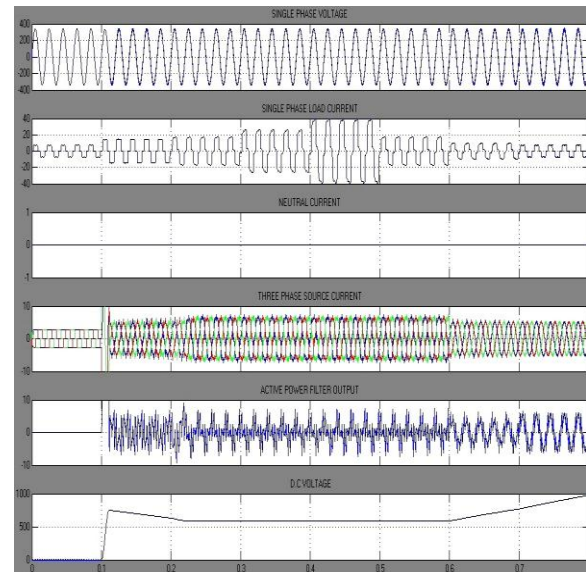

Fig 6 MATLAB/SIMULINK OUTPUTS SINGLE PHASE VOLTAGE, SINGLE PHASE LOAD CURRENT, NEUTRAL CURRENT, THREE PHASE SOURCE CURRENT, ACTIVE POWER FILTER OUTPUT, D.C VOLTAGE

B) EXTENSION RESULTS

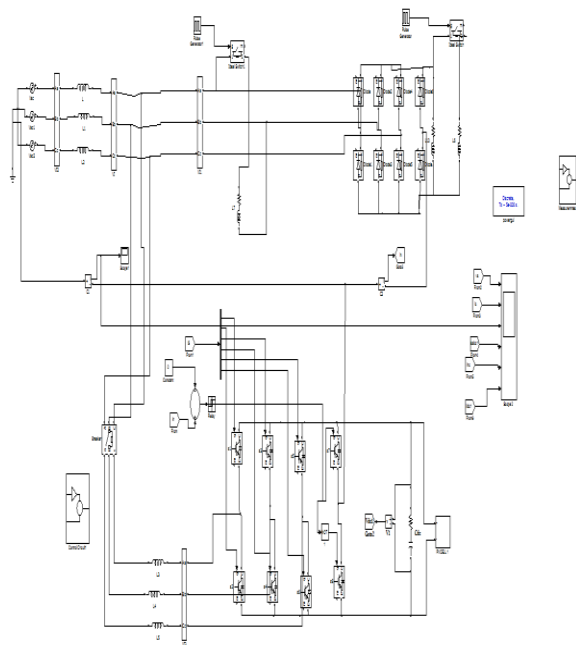

FIG 5 MATLAB/SIMULINK CIRCUIT DIAGRAM OF PROPOSED MODEL

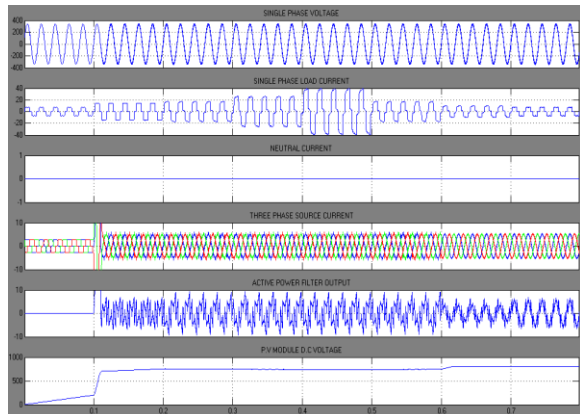

Fig 6 MATLAB/SIMULINK OUTPUTS SINGLE PHASE VOLTAGE,SINGLE PHASE LOAD CURRENT,NEUTRAL CURRENT,THREE PHASE SOURCE CURRENT,ACTIVE POWER FILTER OUTPUT,PV MODULE D.C VOLTAGE

CONCLUSION

Improved system performance is observed after the introduction of P.V module as an input to active power filter which includes the compensation of reactive power, and current harmonics by numerically reducing the total harmonic distortion of the source current from 30% to 6% on average. Resulting in surge of the quality of power in distribution system to a good extent. The predictive algorithm is proved a better alternate to conventional converters in handling non linear and unbalanced load because of its simplicity.

REFERENCES

[1] Improved Active Power Filter Performance for Renewable Power Generation Systems. IEEE TRANSACTIONS ON POWER ELECTRONICS, VOL. 29, NO. 2, FEBRUARY 2014

[2] J. Rocabert, A. Luna, F. Blaabjerg, and P. Rodriguez, "Control of power converters in AC microgrids," IEEE Trans. Power Electron., vol. 27, no. 11, pp. 4734–4749, Nov. 2012.

[3] M. Aredes, J. Hafner, and K. Heumann, "Three-phase four-wire shunt active filter control strategies," IEEE Trans. Power Electron., vol. 12, no. 2, pp. 311–318, Mar. 1997.

[4] S. Naidu and D. Fernandes, "Dynamic voltage restorer based on a four leg voltage source converter," Gener. Transm. Distrib., IET, vol. 3, no. 5, pp. 437–447, May 2009.

[5] N. Prabhakar and M. Mishra, "Dynamic hysteresis current control to minimize switching for three-phase four-leg VSI topology to compensate nonlinear load," IEEE Trans. Power Electron., vol. 25, no. 8, pp. 1935–1942, Aug. 2010.

[6] V. Khadkikar, A. Chandra, and B. Singh, "Digital signal processor implementation and performance evaluation of split capacitor, four-leg and three h-bridge-based three-phase four-wire shunt active filters," Power Electron., IET, vol. 4, no. 4, pp. 463–470, Apr. 2011.

[7] F. Wang, J. Duarte, and M. Hendrix, "Grid-interfacing converter systems with enhanced voltage quality for microgrid application; concept and implementation," IEEE Trans. Power Electron., vol. 26, no. 12, pp. 3501–3513, Dec. 2011.

[8] X. Wei, "Study on digital pi control of current loop in active power filter," in Proc. 2010 Int. Conf. Electr. Control Eng., Jun. 2010, pp. 4287–4290.

[9] R. de Araujo Ribeiro, C. de Azevedo, and R. de Sousa, "A robust adaptive control strategy of active power filters for power-factor correction, harmonic compensation, and balancing of nonlinear loads," IEEE Trans. Power Electron., vol. 27, no. 2, pp. 718–730, Feb. 2012.

[10] J. Rodriguez, J. Pontt, C. Silva, P. Correa, P. Lezana, P. Cortes, and U. Ammann, "Predictive current control of a voltage source inverter," IEEE Trans. Ind. Electron., vol. 54, no. 1, pp. 495–503, Feb. 2007.

[11] P. Cortes, G. Ortiz, J. Yuz, J. Rodriguez, S. Vazquez, and L. Franquelo, "Model predictive control of an inverter with output LC filter for UPS applications," IEEE Trans. Ind. Electron., vol. 56, no. 6, pp. 1875–1883, Jun. 2009.

[12] R. Vargas, P. Cortes, U. Ammann, J. Rodriguez, and J. Pontt, "Predictive control of a three-phase neutral-point-clamped inverter," IEEE Trans. Ind. Electron., vol. 54, no. 5, pp. 2697–2705, Oct. 2007.

[13] P. Cortes, A. Wilson, S. Kouro, J. Rodriguez, and H. Abu-Rub, "Model predictive control of multilevel cascaded H-bridge inverters," IEEE Trans. Ind. Electron., vol. 57, no. 8, pp. 2691–2699, Aug. 2010.

[14] P. Lezana, R. Aguilera, and D. Quevedo, "Model predictive control of an asymmetric flying capacitor