

# Delay optimization of 32-bit Variable Hybrid Carry SkipAdder(CSKA)

K.Lakshmi Tejaswi & Dr.K.Babulu

<sup>1</sup>Research Associate ,Dept. of Electronics and Communication Engineering ,UCEK(A), JNTUK,Kakinada, Andhra Pradesh, India

<sup>2</sup>Professor ,Dept. of Electronics and Communication Engineering ,UCEK(A), JNTUK,Kakinada,Andhra Pradesh, India

## Abstract:

The Carry skip adder (CSKA) is an efficient adder in terms of power consumption and area usage as the critical path delay and power-delay product of CSKA is small compared to other conventional adders. However the use of Multiplexer for Carry skip logic in CSKA causes increase in power consumption due to the use of large number of Transistors(i.e.,12). Hence, a power efficient CSKA called Concatenation-Incrementation (CI-CSKA) has been proposed. In CI-CSKA,the power reduction can be enhanced by replacing the Multiplexer that is used to skip the carry with Or-And-Invert (OAI)/And-Or Invert(AOI) logic. As the number of transistors is reduced to half by using AOI/OAI logic when compare to MUX, Power reduction is achieved without compromising the speed making it suitable for wide range of low power applications.For further improvement in delay,hybrid variable CI-CSKA has been proposed.Here the size of each stage is varied with increment in size from stage1 to nucleus stage and then decrement to the final stage.Simulations by using hybrid variable latency CSKA produces a high speed and reduce the power consumption..

## Keywords:

Carry skip adder(CSKA),speed efficient,hybrid variable stage size adder.

## 1. Introduction

Addition is the most basic arithmetic operation and it plays a vital role in filter designs, processors and DSP applications. Now-a-days, adders are mostly used in the microprocessor designs and Digital Signal Processing-chips. Adders are essential not only for addition, but also for subtraction, multiplication, and division. A fast and accurate operation of the digital system is greatly influenced by the performance of the high speed adders.In VLSI industry,power and delay are the performance parameters that shows adverse effect on any design.So,we have to design the architecture in such a way that it should have low power,should occupy

less area and should get the result in less time(i.e., should have the less delay).Now-a-days there is an increase in demand for portable equipments such as cellular phones and notebook personal computer,so there is a need of using area and power efficient VLSI circuits.

Low-power and high-speed adder cells have wide range of applications for instance, battery operation based devices.Now the challenge is to design the adder with less power consumption maintaining the high performance in different types of circuits.Until now, the power consumption has not been a big deal because of the availability of large packages and other cooling techniques in wide ranges and they have the capability of dissipating the generated heat.But increasing density in addition to the size of the chips and systems may cause the difficulty in providing adequate cooling.So, this will add either add significant cost to the system or provide a limit on the amount of the functionality that can be provided. So, additional equipment (i.e.,cooling techniques) cannot be used in all the applications because it leads to the increase in the area occupancy of a circuit.Adder with less area and power consumption is Ripple Carry Adder(RCA),but the major drawback in it is its low speed.On the other hand ,adder with less delay is Carry Look ahead Adder(CLA) but because of its large area it cannot be used in all the applications.The adder which satisfies all those requirements(i.e.,power,area,delay) is Carry Skip Adder (CSKA). In addition, its speed is much higher than simple ripple carry adder (RCA), while being almost equivalent in terms of low area and power dissipation.

Different techniques are applied to conventional CSKA to have a good compromise between speed and power consumption. A Conv-CSKA consists of full adder gates and get divided into equal number of blocks in case of fixed stage style, whose configuration (i.e., the number of full adders per block) greatly affects the overall speed. The blocks are connected by a skip logic.This logic was implemented by using 2:1 multiplexers(which requires 12 transistors to implement) in case of a conventional CSKA.Later,the 2:1 multiplexers used for skip logic were replaced by AOI and OAI

inverters(requires only 6 transistors to implement leads to the decrement in power and area usage).The number of RCAs in each stage is varied for further decrement in delay whereas the power and area are almost comparable to the previous technique.

## 2. Previous work

The Conv-CSKA consists of stages in which each stage contains chain of full adders (FAs) (RCA block) and 2:1 multiplexer (carry skip logic). The Multiplexer is used to skip the carry to next stage. In case of RCA, the worst case delay occurs when the two N-bit numbers are in propagate mode. The delay for an N-bit RCA can be calculated by the following mathematical expression,

$$T = (n - 1)t_c + t_s$$

Where  $t_s$  is the delay used to compute the sum of the last stage and  $t_c$  is the delay through the carry stage of a different FA. The major drawback in it is carryin for the present stage is obtained only after the carry produced from the previous stage. But due to its excellent advantage in simplest architecture it cannot be replaced, so a modified structure in RCA known as carry skip adder was designed.

The architecture of Conv-CSKA is as follows;

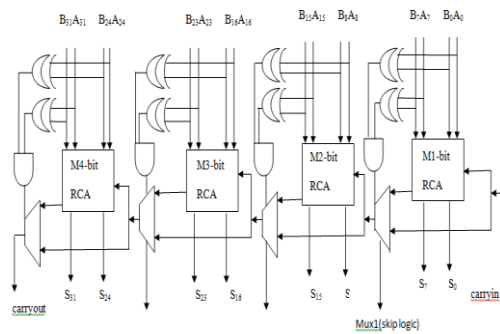

Figure 1. Architecture of Conv-CSKA

In Conv-CSKA structure, the main target is to reduce the delay by modifying its implementation based on the static CMOS design. The modification increases the speed with area and power consumption comparable to that of RCA.

$$P_i = A_i \oplus B_i, i = 1, 2, \dots, N$$

Where  $P_i$  is the propagation related to  $A_i$  and  $B_i$ . Therefore, it shows that the delay of RCA is linearly related to  $N$ . In the case, where cascaded FAs are in the propagated mode, the carry output of the chain is equal to the carry input. The carry skip logic in CSKA detects this situation. It doesn't wait for the operation of FA chain to be completed and it makes the carry ready for next stage. The skip operation is performed by using the multiplexer and gates as shown in the figure. Based on the explanation, in

CSKA the  $N$  FAs are grouped in  $Q$  stages. Each stage contains one RCA block with a skip logic and  $M_j$  FAs (8) where  $j=1, \dots, Q$  (= $4$ ) [Totally 4 stages (8 FAs at each stage), 32-bit adder]. The conventional structure of the CSKA consists of stages that contains chain of 2:1 multiplexer (carry skip logic) and FAs. Through 2:1 multiplexer RCA blocks are connected to each other which can be used in one or more level structures.

In each stage the input of the multiplexer (skip logic) are the carry input of the stage and the output of its RCA block (FA chain) is the carry output. The product of the stage is used as a selector signal of the multiplexer. The CSKA is implemented by using Fixed Stage Size (FSS) and Variable Stage Size (VSS). The highest speed is obtained for the VSS structure. For the implementation of skip logic MUX is used which requires 12 transistors for its implementation. This leads to the hardware complexity. So, MUX used in skip logic was replaced by AOI, OAI gates which requires only 6 transistors. Hence, there is 50% decrement in area usage and power consumption. The structure whose skip logic contains AOI, OAI gates is named as CI-CSKA (Concatenation and Incrementation Carry Skip Adder).

The architecture of CI-CSKA is as follows;

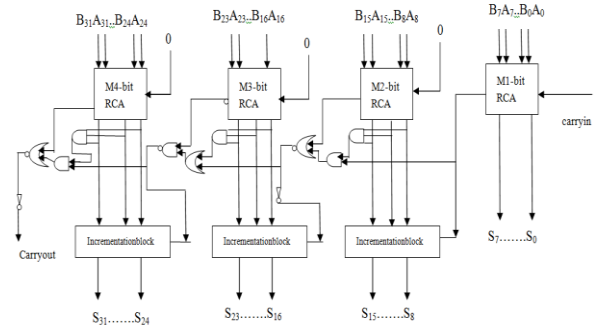

Figure 2. Architecture of CI-CSKA

### 2.1. Delay of the proposed structure:

The use of static AOI and OAI gates which requires six transistors for the implementation leads to decrement in the area. This further reduces the delay. Except for the first RCA block all the inputs for the remaining RCA blocks are given as zero (i.e., carryin) hence the name concatenated. The obtained intermediate result is given to incrementation block to get the final SUM.

The critical path of the proposed structure contains three parts, which includes chain of FAs of first stage, path of the skip logics, incrementation block in the last stage. Hence, the path delay can be expressed as,

$$T_D = [M_1 T_{CARRY}] + [(Q-2)T_{SKIP}] + [(M_Q - 1)T_{AND} + T_{XOR}]$$

$T_{AND}, T_{XOR}$  are the delays of inputs AND and XOR gates. The delay of the skip logic depends on the average of delays of AOI and OAI gates.

$$T_D = [M_1 T_{CARRY}] + \left[ (Q-2) \left( \frac{T_{AOI} + T_{OAI}}{2} \right) \right] + [(M_Q - 1)T_{AND} + T_{XOR}]$$

$T_{AOI}, T_{OAI}$  are the delays of AOI and OAI gates.

### 2.2. Calculation of stage sizes

The size of each stage can be obtained by the following expression,

$$M_{opt} = \sqrt{\frac{N(T_{AOI} + T_{OAI})}{2(T_{CARRY} + T_{AND})}}$$

For a 32-bit adder optimum obtained value is 8. Hence each stage contains 8 FAS, so in order to have 32-bit adder totally four stages are required.

### 3. Proposed Variable Hybrid CI-CSKA

In variable hybrid CI-CSKA to have further decrement in delay the size of each stage is varied (i.e., number of RCAs in each block). The number of RCAs in each block were increased up to the nucleus stage (stage with larger size), from there, number of RCAs in each block were decreased. The stage with larger size is implemented with Brent kung adder since it has good compromise between delay and power consumption.

The architecture of variable Hybrid CI-CSKA is shown in the following figure,

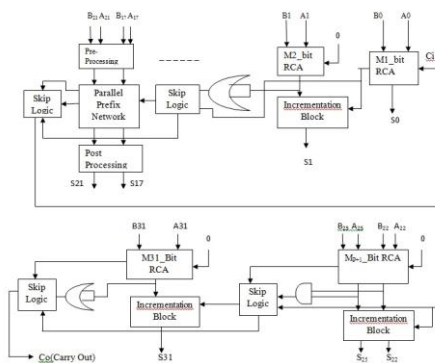

Figure3: Architecture of Variable Hybrid CI-CSKA

In variable hybrid CSKA structure, size of each stage is varied by considering the following steps:  
 1) The size of first stage is one (i.e., number of FAs in RCA block is one).

2) Based on the delay of product of sum of its RCA block and delay of carry output of present stage the size of the next stage is determined. So, from second stage to nucleus stage the size of RCA block (i.e., number of FAs in each RCA block) gradually increases.

3) The above step is repeated until the summation of all the sizes up to the nucleus stage becomes larger than  $N/2$  (where  $N$  is size of the adder).

4) After the nucleus stage to the last stage, the size of stage is determined based on the delay of incrementation block of present and previous stages and delay of skip logic.

The design of a carry skip adder is based on the definition of propagate and generate signals and is mathematically expressed as follows:

$$P_i = A_i \oplus B_i,$$

$$G_i = A_i \bullet B_i$$

Where  $P_i$  is the propagate signal and  $G_i$  is the generate signal, and  $A_i$  and  $B_i$  are the input bits. The carryout from the  $i$ th stage (carry input to  $(i+1)$ th stage) is expressed as,

$$C_{i+1} = G_i + P_i C_i$$

The architecture of Brent kung Adder is as follows:

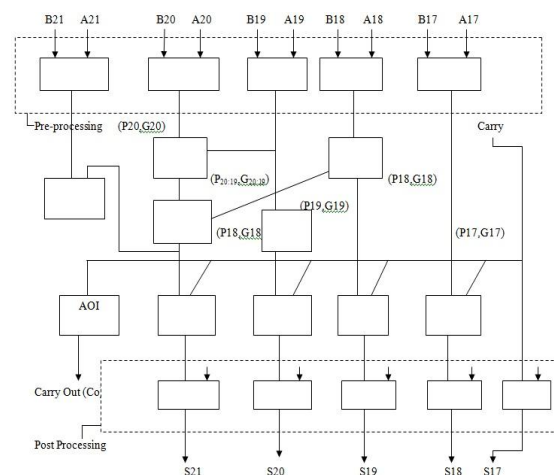

Figure4: Architecture of Brent Kung Adder

As shown in the figure 4, in the pre-processing level, propagate and generate signals are calculated from the input bits and is as shown in Fig 4. In the second level Brent Kung adder is used to calculate the longest carry, this was generated ahead when compared to any other intermediate signal. For a 5-bit adder if normal RCA is used carry is generated after five stages, but in case of Brent Kung adder Carryout is obtained after three levels [13] so, delay is further more reduced. In the third level i.e., postprocessing level, the output sums are calculated.

#### 4. Results and Discussion

When compared to CONV-CSKA there is 50% decrement in the delay in CI-CSKA. By varying the sizes of stages delay can further be decremented.

**Table 1. Delay comparison of Conv-CSKA, CI-CSKA, Variable Hybrid CSKA**

Structure	Delay
Conv-CSKA	47.472ns
CI-CSKA	22.066ns
Variable Hybrid CSKA	21.55ns

By replacing MUX with AOI and OAI gates area reduced to 50% there by decrease in the 50% delay. By varying the sizes of each stage there is further decrement in delay.

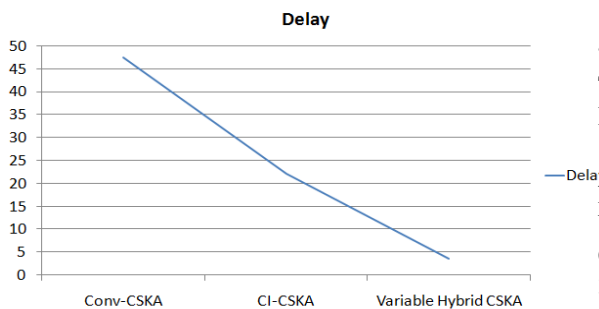

**Figure 5. Delay comparison for Conv-CSKA, CI-CSKA, Variable Hybrid CSKA**

#### 5. Conclusion

In Conv-CSKA use of 2:1 multiplexers for the skip logic causes more delay and area since it requires 12 transistors to implement. So, in the CI-CSKA technique these 2:1 multiplexers got replaced by AOI, OAI gates which requires only 6 transistors to implement causing a decrement in area, power, delay. In CI-CSKA delay is reduced to 50% when compared with the Conv-CSKA. By varying the sizes of each stage in Variable Hybrid CSKA with Brent Kung Adder in the nucleus stage all the performance parameters were improved.

#### 6. References

[1] I. Koren, Computer Arithmetic Algorithms, 2nd ed. Natick, MA, USA: A K Peters, Ltd., 2002.

[2] R. Zlatanovici, S. Kao, and B. Nikolic, "Energy-delay optimization of 64-bit carry-lookahead adders

with a 240 ps 90 nm CMOS design example," IEEE J. Solid-State Circuits, vol. 44, no. 2, pp. 569–583, Feb. 2009.

[3] S. K. Mathew, M. A. Anders, B. Bloechel, T. Nguyen, R. K. Krishnamurthy, and S. Borkar, "A 4-GHz 300-mW 64-bit integer execution ALU with dual supply voltages in 90-nm CMOS," IEEE J. Solid-State Circuits, vol. 40, no. 1, pp. 44–51, Jan. 2005.

[4] V. G. Oklobdzija, B. R. Zeydel, H. Q. Dao, S. Mathew, and R. Krishnamurthy, "Comparison of high-performance VLSI adders in the energy-delay space," IEEE Trans. Very Large

[5] B. Ramkumar and H. M. Kittur, "Low-power and area-efficient carry select adder," IEEE Trans. Very Large Scale Integr. (VLSI) Syst., vol. 20, no. 2, pp. 371–375, Feb. 2012.

[6] M. Vratonjic, B. R. Zeydel, and V. G. Oklobdzija, "Low- and ultra low-power arithmetic units: Design and comparison," in Proc. IEEE Int. Conf. Comput. Design, VLSI Comput. Process. (ICCD), Oct. 2005, pp. 249–252.

[7] C. Nagendra, M. J. Irwin, and R. M. Owens, "Area-time-power tradeoffs in parallel adders," IEEE Trans. Circuits Syst. II, Analog Digit. Signal Process., vol. 43, no. 10, pp. 689–702, Oct. 1996.

[8] Y. He and C.-H. Chang, "A power-delay efficient hybrid carrylookahead/ carry-select based redundant binary to two's complement converter," IEEE Trans. Circuits Syst. I, Reg. Papers, vol. 55, no. 1, pp. 336–346, Feb. 2008.

[9] C.-H. Chang, J. Gu, and M. Zhang, "A review of 0.18 μm full adder performances for tree structured arithmetic circuits," IEEE Trans. Very Large Scale Integr. (VLSI) Syst., vol. 13, no. 6, pp. 686–695, Jun. 2005.

[10] D. Markovic, C. C. Wang, L. P. Alarcon, T.-T. Liu, and J. M. Rabaey, "Ultralow-power design in near-threshold region," Proc. IEEE, vol. 98, no. 2, pp. 237–252, Feb. 2010.

[11] R. G. Dreslinski, M. Wieckowski, D. Blaauw, D. Sylvester, and T. Mudge, "Near-threshold computing: Reclaiming Moore's law through energy efficient integrated circuits," Proc. IEEE, vol. 98, no. 2, pp. 253–266, Feb. 2010.

[12] S. Jain et al., "A 280 mV-to-1.2 V wide-operating-range IA-32 processor in 32 nm CMOS," in IEEE Int. Solid-State Circuits Conf. Dig. Tech. Papers (ISSCC), Feb. 2012, pp. 66–68.

[13] R.P. Brent and H.T. Kung, "A regular layout for parallel adders," IEEE Trans. Comput., vol. C-31, no. 3, pp. 260–264, Mar. 1982.