



# Diode-clamped multilevel inverters with DC voltage balancing circuit based on RSCC with voltage boost function

Chennaiah Banoth<sup>1</sup>, Mahender kodela<sup>2</sup>, Kumaraswamy Madavena<sup>3</sup>

<sup>1</sup> Assistant Professor Department of Facilities and Services Planning (Building Technology and services), Jawaharlal Nehru Architecture and Fine Arts University, Hyderabad, Telangana, India

<sup>2</sup> Assistant Professor Department of Electrical and Electronics Engineering, Vaagdevi College Of Engineering, warangal, Telangana, India.

<sup>3</sup> Associate Professor Department of Electrical and Electronics Engineering, Ganapthi Engineering College, warangal, Telangana, India.

[banoth.chennaiah@gmail.com](mailto:banoth.chennaiah@gmail.com) & [mahi.kodela@gmail.com](mailto:mahi.kodela@gmail.com) & [kumar21sriram@gmail.com](mailto:kumar21sriram@gmail.com)

**Abstract**— Multilevel inverters are mainly used in medium voltage and high power applications to reduce the required voltage rating of the power semiconductor switching devices. On the other hands, these multilevel inverters are attractive for various applications regardless of the power ratings because they can essentially realize lower harmonics with lower switching frequency and lower electromagnetic interference (EMI). In this context, the multilevel inverters with larger number of levels suitable for circuit integration are actively investigated. Diode-clamped multilevel inverters are regarded as the promising solution. In the diode-clamped multilevel inverters whose number of the levels exceeds three, voltage balancing circuits for the DC capacitors to maintain the proper voltage are indispensable. The authors have been investigated the application of a circuit topology of the voltage balancing circuits so called Resonant Switched Capacitor Converters (RSCC). In the present paper, The voltage boost function is useful in the applications in which the DC source voltage is limited such as batteries and fuel cells, the usefulness and the operating characteristics of the voltage boost operation have been demonstrated. the utilization of the voltage boost function of RSCC to enhance the allowable range of the input voltage of the inverter is investigated.. From the computer simulation results.

**Keywords**— Multilevel inverters, voltage balancing circuit, boost function, Diode-Clamped Inverter

## I. INTRODUCTION

Numerous industrial applications have begun to require higher power apparatus in recent years. Some medium voltage motor drives and utility applications require medium voltage and megawatt power level.

For a medium voltage grid, it is troublesome to connect only one power semiconductor switch directly. As a result, a multilevel power converter structure has been introduced as an alternative in high power and medium voltage situations. A multilevel converter not only achieves high power ratings, but also enables the use of renewable energy sources. Renewable energy sources such as photovoltaic, wind, and fuel cells can be easily interfaced to a multilevel converter system for a high power application [1-3]. The concept of multilevel converters has been introduced since 1975 [4]. The term multilevel began with the three-level converter [5]. Subsequently, several multilevel converter topologies have been developed [6-13]. However, the elementary concept of a multilevel converter to achieve higher power is to use a series of power semiconductor switches with several lower voltage dc sources to perform the power conversion by synthesizing a staircase voltage waveform. Capacitors, batteries, and renewable energy voltage sources can be used as the multiple dc voltage sources. The commutation of the power switches aggregate these multiple dc sources in order to achieve high voltage at the output; however, the rated voltage of the power semiconductor switches depends only upon the rating of the dc voltage sources to which they are connected. A multilevel converter has several advantages over a conventional two-level converter that uses high switching frequency pulse width modulation (PWM). The attractive features of a multilevel converter can be briefly summarized as follows. • Staircase waveform quality: Multilevel converters not only can generate

the output voltages with very low distortion, but also can reduce the dv/dt stresses; therefore electromagnetic compatibility (EMC) problems can be reduced.

- Common-mode (CM) voltage: Multilevel converters produce smaller CM voltage; therefore, the stress in the bearings of a motor connected to a multilevel motor drive can be reduced. Furthermore, CM voltage can be eliminated by using advanced modulation strategies such as that proposed in [14].
- Input current: Multilevel converters can draw input current with low distortion.
- Switching frequency: Multilevel converters can operate at both fundamental switching frequency and high switching frequency PWM. It should be noted that lower switching frequency usually means lower switching loss and higher efficiency. Unfortunately, multilevel converters do have some disadvantages. One particular disadvantage is the greater number of power semiconductor switches needed. Although lower voltage rated switches can be utilized in a multilevel converter, each switch requires a related gate drive circuit. This may cause the overall system to be more expensive and complex.

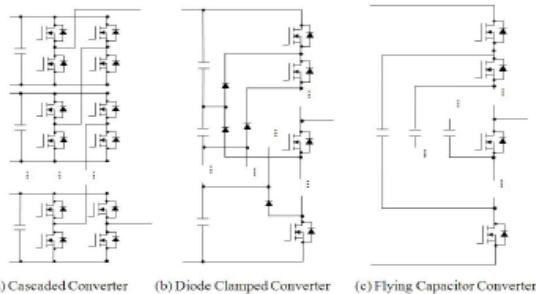

Fig.1 Typical Circuit Topologies of Multilevel Inverters.

In this paper, a new possibility of the RSCC to enhance the operating range of the output voltage is focused on. In the following, the basic operating principle is overviewed. And then, As mentioned above, the RSCC can realize the voltage balance of the series connected DC capacitors in the diode clamped multilevel converters. Depending on the terminals of the series connected DC capacitors to which the DC power source is connected, voltage boost capability can be obtained. a new arrangement of the RSCC to realize the voltage boost capability is proposed. To confirm the proper operation and the usefulness of the proposed method, some simulated results and experimental results employing a

prototype 5-level diode clamped multilevel inverter are included

## II. VOLTAGE BALANCING CIRCUIT BASED ON RSCC

### A. Basic Operating Principle

Fig.2(a) shows the basic circuit configuration of a unit of the RSCC. The unit of RSCC consists of four switching devices, a resonant inductor  $L_r$ , and a resonant capacitor  $C_r$ . Each switching device is operated at a 50% duty factor and the resonant frequency determined by  $L_r$  and  $C_r$  as shown in Fig.2(b). Under the condition that the voltage  $V_{C1}$  of capacitor  $C_1$  is larger than  $V_{C2}$  of capacitor  $C_2$ ,  $C_r$  is charged by  $C_1$  when two switches  $S_1$  and  $S_2$  are in the on-state (State I). Then,  $C_2$  is charged by  $C_r$  when two switches  $S_{1p}$  and  $S_{2p}$  are in the on-state (State II). In

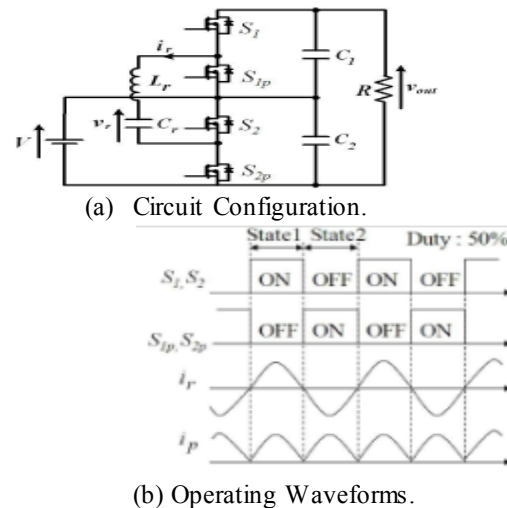

Fig.2 Operating Principle of Resonant Switched Capacitor Converter

this way, the excessive charge in  $C_1$  is transferred to  $C_2$  by repeating the switching operation. In principle,  $V_{C1}$  and  $V_{C2}$  can be balanced without any feedback control by changing the amplitude and direction of  $i_r$  automatically.

### B. Application to Multilevel Inverters and Voltage Boost Function

Fig.3 (a), (b) and (c) show examples of the arrangement of the RSCC to 5-level diode-clamped multilevel inverters with main circuit configuration per phase. An ordinal connection to 5-level diode clamped multilevel inverter is shown in Fig.3 (a). In this case, the voltage balance in the upper two capacitors  $C_1$  and  $C_2$  is achieved by the upper

RSCC. On the other hands, the lower RSCC achieves the voltage balance in C3 and C4. Due to the symmetrical operation of the diode clamped inverter, the total voltages of the upper half capacitors C1, C2, and that of the lower half capacitors C3, C4 can be balanced essentially in the steady state. As the result, all the capacitor voltage can be balanced. In the case shown in Fig.3 (a), each DC capacitor shares equally one fourth of the DC supply voltage V. In this case, the possible levels of the output phase voltage are V, (3/4)V, (1/2)V, (1/4)V, 0.

Fig.3(b) shows the proposed voltage boost connection of the RSCC. In this case, the DC voltage source V is connected to the intermediate terminals "b" and "d" of the DC circuit. In this case, C2 and C3 share a half of the DC voltage (1/2)V equally due to the symmetrical operation of the diode-clamped inverter. By the function of the upper RSCC, the voltages of C1 and C2 are balanced. Consequently, the voltage of C1 is also (1/2)V. The lower RSCC realizes the voltage balance between C3 and C4. And then, all the voltages in C1-C4 become (1/2)V. Consequently, the possible levels of the output phase voltage are 2V, (3/2)V, V, (1/2)V, 0. In this way, the

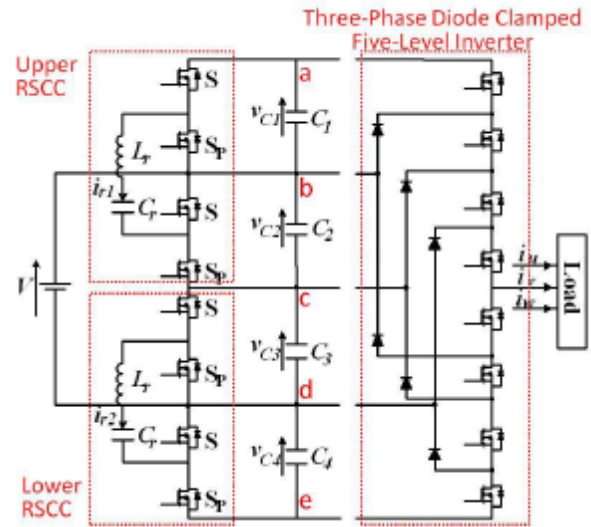

(b) Proposed Voltage Boost Connection

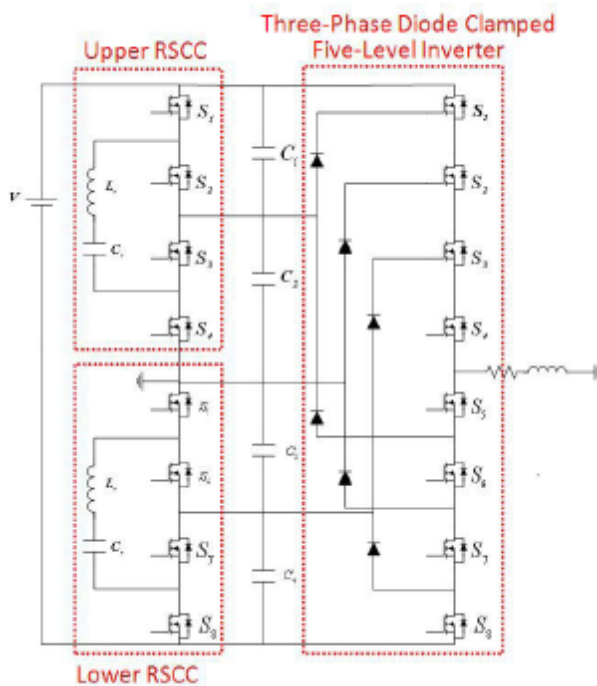

(a) Ordinal Connection

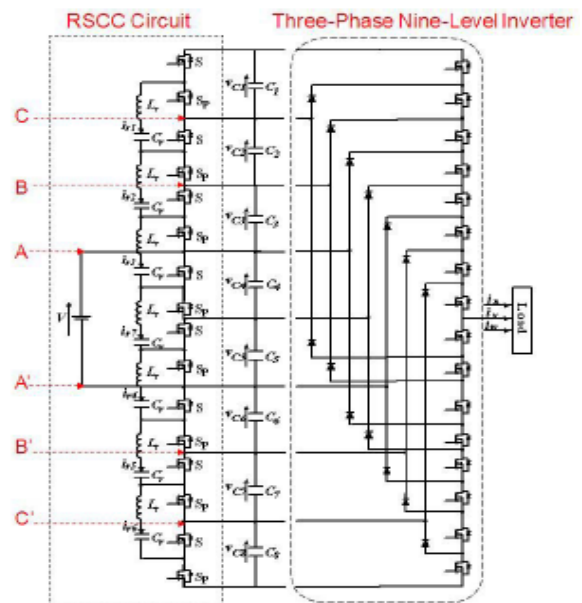

(c) Modified Version of Proposed Voltage Boost Connection

Fig.3 Variations of Circuit Configuration of 9-Level Multilevel Diode Clamped Inverters with RSCC.

voltage boost function can be obtained. This function is useful to enhance the operating range of the output voltage with the limited value of the DC supply voltage. Note that the voltage boost ratio is determined by the number of series connected capacitors and the connecting points of the DC voltage source.

Fig.3(c) shows the modified connection of Fig.3(b). In Fig.3(b), the average values of the voltages of C2 and C3 are balanced in a fundamental

period of the output frequency. But, these voltages fluctuate due to the instantaneous imbalance of the currents flowing out from C2 and C3. Thus, an additional RSCC is effective to ensure the instantaneous voltage balance in C2 and C3. The additional RSCC can be realized by adding only an inductor and a capacitor shown in Fig.3(c) and no additional switching devices are needed.

Table 1 Parameters of Experimental Prototype.

Input Voltage	50V
Inductor of RSCC	1 $\mu$ H
Capacitor of RSCC	9.4 $\mu$ F
Resonant Frequency of RSCC	50kHz
On Resistance of Main MOSFET's	0.04 $\Omega$
Forward Voltage Drop of Diodes	1V
Equivalent Series Resistance of RSCC	0.03 $\Omega$
DC Link Capacitor	1mF, 560 $\mu$ F, 22

### I. SIMULATION RESULTS

Fig.11 An Example of Extension of RSCC to 9-Level Inverters.

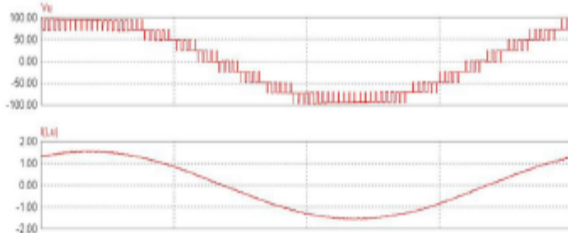

Fig.1 Simulated Output Waveforms of an RSCC to 9- Level Converters. (Upper: Output Voltage, Lower: Output Current).

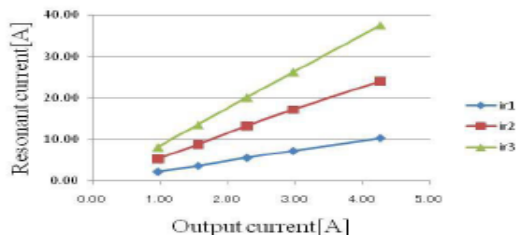

Fig.2 Simulated Result of Relationship between Resonant Current and Output Current in Circuit Configuration shown in Fig.11.

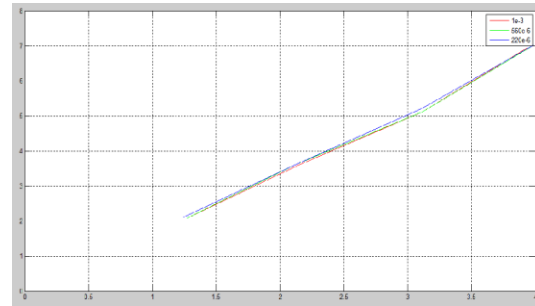

Fig.2 Simulated Result of Relationship between Resonant Current and Output Current for Different Values of DC Link Capacitor.

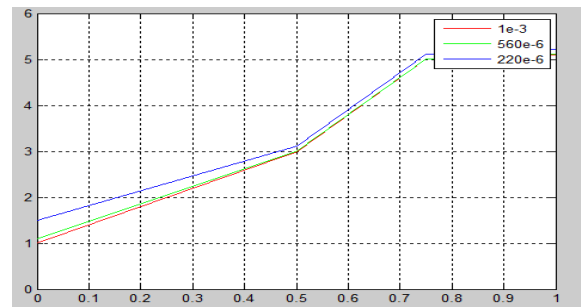

Fig.3 Simulated Result of Relationship between Resonant Current and Load Power Factor for Different Values of DC Link Capacitor.

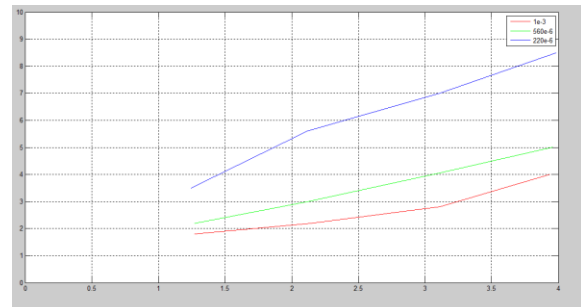

Fig.4 Simulated Result of Relationship between Ripple Voltage of DC Capacitor and Output Current for Different Values of Capacitance.

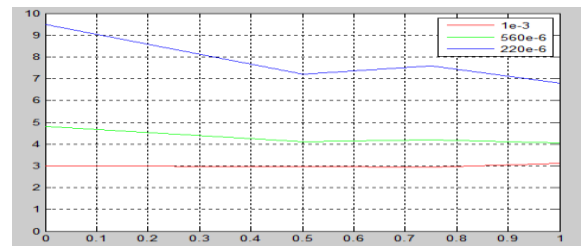

Fig.5 Simulated Result of Relationship between Resonant Current and Output Current for Different Values of DC Link Capacitor.

**Ripple Voltage of DC Capacitor and Load Power Factor for Different Values of Capacitance.**

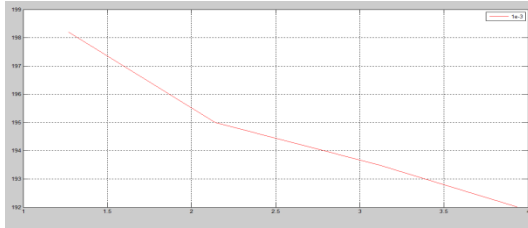

Fig.6 Simulated Result of Relationship between Voltage Boost Ratio and Output Current.

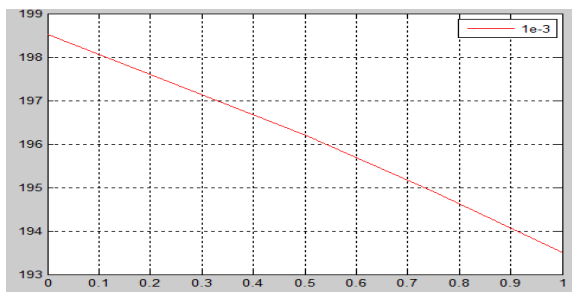

Fig.7 Simulated Result of Relationship between Voltage Boost Ratio and Load Power Factor.

**C. Ripple Voltage of DC Capacitor**

Fig.7 shows the relationship between the ripple voltage of the DC capacitor and the load current for three different capacitances of the DC capacitor. When the output current is large, the ripple voltage becomes large. In addition, the smaller capacitance results in the larger ripple voltage. Fig.8 shows the relationship between the ripple voltage of the DC capacitor and the load power factor. Again, we can see that the smaller capacitance results in the larger ripple voltage. But, the dependence of the ripple voltage on the load power factor is not significant in this experiment.

**D. Voltage Boost Ratio**

Fig.9 shows the experimental result of the relationship between the voltage boost ratio and the load current in the modified circuit shown in Fig.3(c). The voltage boost ratio is defined as a ratio of the

maximum output phase voltage with respect to the DC source voltage. When the load current increases, the voltage boost ratio decreases slightly. Fig.10 shows the relationship between the voltage boost ratio and the load power factor. When the load power factor is high, the voltage boost ratio decreases slightly. From the results of Figs.9 and 10, the voltage boost ratio decreases when the active power increases. When the active power increases, the current of the RSCC increases. In this condition, the voltage drop in the MOSFET's and the equivalent resistance of the resonant components of the RSCC increases. Thus, the DC capacitor voltage decreases and then the voltage boost ratio is reduced. In the circuit connection shown in Fig.3(c), the theoretical value of the voltage boost ratio is 2. Thus, the difference between the actual and theoretical values of the voltage boost ratio is about 4% in Figs.9 and 10. From these results, we can conclude that the proposed voltage boost function can achieve a practical voltage regulation.

**V. CONCLUSIONS**

In this paper, the diode-clamped multilevel inverters with DC voltage balancing circuit based on RSCC with voltage boost function are proposed. The basic effectiveness of the proposed method has been In addition, various characteristics useful for the selection of the circuit parameters are obtained. Furthermore, the extension of the proposed method to the multilevel inverters with large number of output levels has been demonstrated by computer simulation.

**REFERENCES**

- [1] J. W. Kolar, U. Drogenik, J. Biela, M. L. Heldwein, H. Ertl, T. Friedli, and S. D. Round, "PWM Converter Power Density Barriers," Proceedings of the 4th Power Conversion Conference, 2007, pp. 9-29.
- [2] A. Nabae, I. Takahashi, and H. Akagi, "A New Neutral-Point Clamped PWM Inverter," IEEE Transactions on Industry Applications, Vol. IA-17, No. 5, 1981, pp. 518-523.
- [3] L. G. Franquelo, J. Rodriguez, J. I. Leon, S. Kouro, R. Portillo, and M. A. M. Prats, "The Age of Multilevel Converters Arrives," IEEE Industrial Electronics Magazine, 2008, Vol. 2, No. 2, pp. 2839.

- [4] J. Rodriguez, J. S. Lai, and F. Z. Peng, "Multilevel Inverters: A Survey of Topologies, Controls, and Applications," IEEE Transactions on Industrial Electronics, Vol. 49, No. 4, 2002, pp. 724-738.
- [5] J. S. Lai, and F. Z. Peng, "Multilevel Converters-a New Breed of Power Converters," IEEE Transactions on Industry Applications, Vol. 32, No. 3, 1996, pp. 509-517.
- [6] M. Kamaga, K. M. Sung, Y. Hayashi, Y. Sato, and H. Ohashi, "An Investigation of Gate Drive Circuits and Losses in Power Devices of Multilevel Converters for Circuit Integration to Realize High Output Power Density," Proceedings of the 5th International Conference on Integration of Power Electronics Systems, 2008, pp. 139-142.
- [7] T. Kinjo, Y. Hayashi, Y. Sato, and H. Ohashi, "Study on High Power Density Integration of Multilevel Converters," Proceedings of the 4th International Conference on Integration of Power Electronics Systems, 2006, pp. 223-226.
- [8] N. S. Choi, J. G. Cho, and G. H. Cho, "A General Circuit Topology of Multilevel Inverter," Proceedings of the 22nd Annual IEEE Power Electronics Specialists Conference, 1991, pp. 96-103.
- [9] L. M. Grzesiak, and J. G. Tomasik, "A Novel DC Link Balancing Scheme in Generic n-level Back-to-Back Converter System," Proceedings of the 7th International Conference on Power Electronics, 2007, pp. 1044-1049.
- [10] J. C. Rosas-Caro, J. M. Ramirez, and A. Valderrabano, "Voltage Balancing in DC/DC Multilevel Boost Converters," Proceedings of the 40th North American Power Symposium, 2008, pp. 1-7.
- [11] M. Shoyama, T. Naka, and T. Ninomiya, "Resonant Switched Capacitor Converter with High Efficiency," Proceedings of the 35th Annual IEEE Power Electronics Specialists Conference, 2004, Vol. 5, pp. 3780-3786.
- [12] K. Sano, and H. Fujita, "Voltage-Balancing Circuit Based on a Resonant Switched-Capacitor Converter for Multilevel Inverters," IEEE Transactions on Industry Applications, Vol. 44, No. 6, pp. 1768-1776. K. Sano, and H. Fujita, "A Resonant Switched Capacitor Converter for Voltage Balancing of Series-Connected Capacitors," Proceedings of the International Conference on Power Electronics and Drive Systems, 2009, pp. 683-688.
- [13] T. Ito, M. Kamaga, and Y. Sato, "Operating Characteristics of Open-Loop RSCC Connected to Diode-Clamped Multilevel Inverter," Proceedings of

IEEJ Annual Meeting, 2009, 4-043, (in Japanese).

[14] T. Ito, M. Kamaga, and Y. Sato, "An Investigation of DC Capacitors' Voltage Balancing Circuit in Diode-Clamped Multilevel Inverter to Realize High Power Density Converters," Proceedings of IEEJ Annual meeting, 2010, 4-051, (in Japanese).

[15] T. Ito, M. Kamaga, Y. Sato, and H. Ohashi, "An investigation of voltage balancing circuit for DC capacitors in diode-clamped multilevel inverters to realize high output power density converters," IEEE Energy Conversion Congress and Exposition (ECCE), 2010, pp.3675-3682 704-711, Mar. 2003.



**CHENNAIAH BANOTH**

Completed **B.Tech.** in Electrical & Electronics Engineering in 2008 from VAAGDEVI COLLEGE OF ENGINEERING, Bollikunta, Warangal Dist, Affiliated to JNTUH, Hyderabad, Telangana, India. and **M.Tech** in Power Electronics (PE) in 2011 from VAAGDEVI COLLEGE OF ENGINEERING, Bollikunta, Warangal Dist, Affiliated to JNTUH, Hyderabad, Telangana, India. Area of interest includes Power Electronics, Building Electrical services and Building Automation.

E-mail id: [banoth.chennaiah@gmail.com](mailto:banoth.chennaiah@gmail.com)



**MAHENDER KODELA**

Completed B.Tech in Electrical & Electronics Engineering in 2009 from Vaagdevi college of Engineering, warangal Affiliated to JNTUH, Hyderabad and M.Tech in Power Electronics in 2013 from SR Engineering College, Warangal. Working as Assistant Professor at Vaagdevi College Of Engineering, warangal, Telangana, India. Area of interest includes Power Electronics, Control Systems.

E-mail id: [mahi.kodela@gmail.com](mailto:mahi.kodela@gmail.com)



**KUMARASWAMY MADAVENA**

Completed B.Tech in Electrical & Electronics Engineering in 2008 from Vaagdevi college of Engineering, warangal Affiliated to JNTUH, Hyderabad and M.Tech in Control Systems in 2011 from Ramappa Engineering College, Warangal, Telangana, India. Working as Assoc. Professor at Ganapathi Engineering College, warangal, Telangana, India. Area of interest includes Power Electronics, Control Systems.

E-mail id : [kumar21sriram@gmail.com](mailto:kumar21sriram@gmail.com)