



Theory and Application of PN Junction Diode in Physics

Jitendrayogi, SurajBhanSingh, Vishal Verma, Sonu, Deepak Kumar Meena
Department of Physics, Students, B.Sc. Final year, Parishkar College of Global Excellence,
Jaipur

Abstract

In this chapter, we present basic device physics, general characteristics, and operation principles of a p-n junction diode. A p-n junction diode is referred to as a minority carrier device since its current conduction is controlled by the minority carrier diffusion process (i.e., electrons in the p-region and holes in the n-region).

Introduction

If Resistor are the most basic passive component in electrical or electronic circuits, then we have to consider the **Signal Diode** as being the most basic “Active” component. However, unlike a resistor, a diode does not behave linearly with respect to the applied voltage as it has an exponential I-V relationship and therefore cannot be described simply by using Ohm’s law as we do for resistors. Diodes are basic unidirectional semiconductor devices that will only allow current to flow through them in one direction only, acting more like a one way electrical valve, (Forward Biased Condition). But, before we have a look at how signal or power diodes work we first need to understand the semiconductors basic construction and concept.

Diodes are made from a single piece of **Semiconductor** material which has a positive “P-region” at one end and a negative “N-region” at the other, and which has a resistivity value somewhere between that of a conductor and an insulator. But what is a “Semiconductor” material?, firstly let’s look at what makes something either a **Conductor** or an **Insulator**.

Resistivity

The electrical **Resistance** of an electrical or electronic component or device is generally defined as being the ratio of the voltage difference across it to the current flowing through it, basic Ohm Law principals. The problem with using resistance as a measurement is that it depends very much on the physical size of the material being measured as well as the material out of which it is made. For example, if we were to increase the length of the material (making it

longer) its resistance would also increase proportionally. Likewise, if we increased its diameter or size (making it fatter) its resistance value would decrease. So we want to be able to define the material in such a way as to indicate its ability to either conduct or oppose the flow of electrical current through it no matter what its size or shape happens to be. The quantity that is used to indicate this specific resistance is called **Resistivity** and is given the Greek symbol of ρ , (Rho). Resistivity is measured in Ohm-metres, ($\Omega\text{-m}$). Resistivity is the inverse to conductivity.

If the resistivity of various materials is compared, they can be classified into three main groups, Conductors, Insulators and Semi-conductors as shown below.

Conductors

From above we now know that **Conductors** are materials that have very low values of resistivity, usually in the micro-ohms per metre. This low value allows them to easily pass an electrical current due to there being plenty of free electrons floating about within their basic atom structure. But these electrons will only flow through a conductor if there is something to spur their movement, and that something is an electrical voltage.

When a positive voltage potential is applied to the material these “free electrons” leave their parent atom and travel together through the material forming an electron drift, more commonly known as a current. How “freely” these electrons can move through a conductor depends on how easily they can break free from their constituent atoms when a voltage is applied. Then the amount of electrons that flow depends on the amount of resistivity the conductor has.

Examples of good conductors are generally metals such as Copper, Aluminium, Silver or non metals such as Carbon because these materials have very few electrons in their outer “Valence Shell” or ring, resulting in them being easily knocked out of the atom’s orbit.

This allows them to flow freely through the material until they join up with other atoms, producing a “Domino Effect” through the material thereby creating an electrical current. Copper and Aluminium is the main conductor used in electrical cables as shown.



**An
uses
and Insulators**

Electrical

**Cable
Conductors**

Generally speaking, most metals are good conductors of electricity, as they have very small resistance values, usually in the region of micro-ohms per metre. While metals such as copper and aluminium are very good conductors of electricity, they still have some resistance to the flow of electrons and consequently do not conduct perfectly.

The energy which is lost in the process of passing an electrical current, appears in the form of heat which is why conductors and especially resistors become hot. Also the resistivity of conductors increases with ambient temperature because metals are also generally good conductors of heat.

Insulators

Insulators on the other hand are the exact opposite of conductors. They are made of materials, generally non-metals, that have very few or no “free electrons” floating about within their basic atom structure because the electrons in the outer valence shell are strongly attracted by the positively charged inner nucleus.



In other words, the electrons are stuck to the parent atom and can not move around freely so if a potential voltage is applied to the material no current will flow as there are no “free electrons” available to move and which gives these materials their insulating properties.

Insulators also have very high resistances, millions of ohms per metre, and are generally not affected by normal temperature changes (although at very high temperatures wood becomes charcoal and changes from an insulator to a conductor). Examples of good insulators are marble, fused quartz, p.v.c. plastics, rubber etc.

Insulators play a very important role within electrical and electronic circuits, because without them electrical circuits would short together and not work. For example, insulators made of glass or porcelain are used for insulating and supporting overhead transmission cables while epoxy-glass resin materials are used to make printed circuit boards, PCB's etc. while PVC is used to insulate electrical cables as shown.

Semiconductor Basics

Semiconductors materials such as silicon (Si), germanium (Ge) and gallium arsenide (GaAs), have electrical properties somewhere in the middle, between those of a “conductor” and an “insulator”. They are not good conductors nor good insulators (hence their name “semi”-conductors). They have very few “free electrons” because their atoms are closely grouped together in a crystalline pattern called a “crystal lattice” but electrons are still able to flow, but only under special conditions.

The ability of semiconductors to conduct electricity can be greatly improved by replacing or adding certain donor or acceptor atoms to this crystalline structure thereby,

producing more free electrons than holes or vice versa. That is by adding a small percentage of another element to the base material, either silicon or germanium.

On their own Silicon and Germanium are classed as intrinsic semiconductors, that is they are chemically pure, containing nothing but semi-conductive material. But by controlling the amount of impurities added to this intrinsic semiconductor material it is possible to control its conductivity. Various impurities called donors or acceptors can be added to this intrinsic material to produce free electrons or holes respectively.

This process of adding donor or acceptor atoms to semiconductor atoms (the order of 1 impurity atom per 10 million (or more) atoms of the semiconductor) is called **Doping**. The as the doped silicon is no longer pure, these donor and acceptor atoms are collectively referred to as “impurities”, and by doping these silicon material with a sufficient number of impurities, we can turn it into a *semi-conductor*.

The most commonly used semiconductor basics material by far is **silicon**. Silicon has four valence electrons in its outermost shell which it shares with its neighbouring silicon atoms to form full orbital's of eight electrons. The structure of the bond between the two silicon atoms is such that each atom shares one electron with its neighbour making the bond very stable.

As there are very few free electrons available to move around the silicon crystal, crystals of pure silicon (or germanium) are therefore good insulators, or at the very least very high value resistors.

Silicon atoms are arranged in a definite symmetrical pattern making them a crystalline solid structure. A crystal of pure silica (silicon dioxide or glass) is generally said to be an

intrinsic crystal (it has no impurities) and therefore has no free electrons.

But simply connecting a silicon crystal to a battery supply is not enough to extract an electric current from it. To do that we need to create a “positive” and a “negative” pole within the silicon allowing electrons and therefore electric current to flow out of the silicon. These poles are created by doping the silicon with certain impurities.

A Silicon Atom Structure

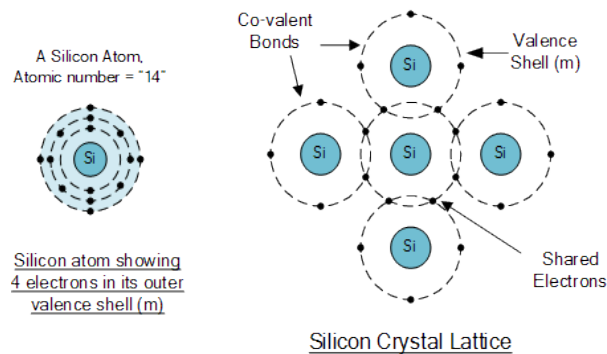

The diagram above shows the structure and lattice of a ‘normal’ pure crystal of Silicon.

N-type Semiconductor Basics

In order for our silicon crystal to conduct electricity, we need to introduce an impurity atom such as Arsenic, Antimony or Phosphorus into the crystalline structure making it extrinsic (impurities are added). These atoms have five outer electrons in their outermost orbital to share with neighbouring atoms and are commonly called “Pentavalent” impurities.

This allows four out of the five orbital electrons to bond with its neighbouring silicon atoms leaving one “free electron” to become mobile when an electrical voltage is applied (electron flow). As each impurity atom “donates” one electron, pentavalent atoms are generally known as “donors”.

Antimony (symbol Sb) as well as **Phosphorus** (symbol P), are frequently used as a pentavalent additive to silicon. Antimony has 51 electrons arranged in five shells around its nucleus with the outermost orbital having five electrons. The resulting semiconductor basics material has an excess of current-carrying electrons, each with a negative charge, and is therefore referred to as an **N-type** material with the electrons called “Majority Carriers” while the resulting holes are called “Minority Carriers”.

When stimulated by an external power source, the electrons freed from the silicon atoms by this stimulation are quickly replaced by the free electrons available from the doped Antimony atoms. But this action still leaves an extra electron (the freed electron) floating around the doped crystal making it negatively charged.

Then a semiconductor material is classed as N-type when its donor density is greater than its acceptor density, in other words, it has more electrons than holes thereby creating a negative pole as shown.

Antimony Atom and Doping

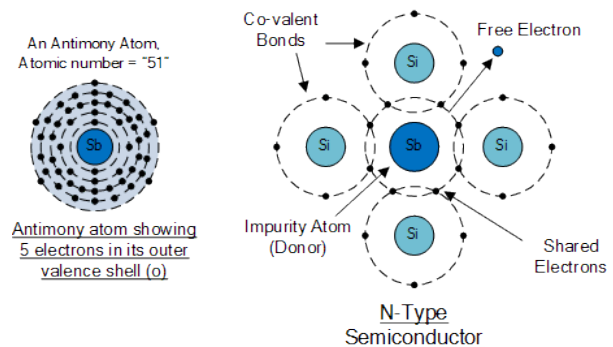

The diagram above shows the structure and lattice of the donor impurity atom Antimony.

P-Type Semiconductor Basics

If we go the other way, and introduce a “Trivalent” (3-electron) impurity into the crystalline structure, such as Aluminium, Boron or Indium, which have only three valence electrons available in their outermost orbital, the fourth closed bond cannot be formed. Therefore, a complete connection is not possible, giving the semiconductor material an abundance of positively charged carriers known as holes in the structure of the crystal where electrons are effectively missing.

As there is now a hole in the silicon crystal, a neighbouring electron is attracted to it and will try to move into the hole to fill it. However, the electron filling the hole leaves another hole behind it as it moves. This in turn attracts another electron which in turn creates another hole behind it, and so forth giving the appearance that the holes are moving as a positive charge through the crystal structure (conventional current flow).

This movement of holes results in a shortage of electrons in the silicon turning the entire doped crystal into a positive pole. As each impurity atom generates a hole, trivalent impurities are generally known as “**Acceptors**” as they are continually “accepting” extra or free electrons.

Boron (symbol B) is commonly used as a trivalent additive as it has only five electrons arranged in three shells around its nucleus with the outermost orbital having only three electrons. The doping of Boron atoms causes conduction to consist mainly of positive charge carriers resulting in a **P-type** material with the positive holes being called “Majority Carriers” while the free electrons are called “Minority Carriers”.

Then a semiconductor basics material is classed as P-type when its acceptor density is greater than its donor density. Therefore, a P-type semiconductor has more holes than electrons.

Boron Atom and Doping

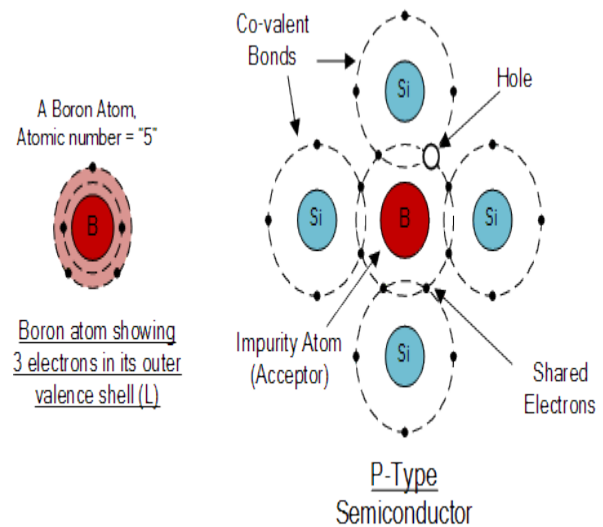

The diagram above shows the structure and lattice of the acceptor impurity atom Boron.

Semiconductor Basics Summary

N-type (e.g. doped with Antimony)

These are materials which have **Pentavalent** impurity atoms (Donors) added and conduct by “electron” movement and are therefore called, **N-type Semiconductors**.

In N-type semiconductors there are:

1. The Donors are positively charged.
2. There are a large number of free electrons.
3. A small number of holes in relation to the number of free electrons.
4. Doping gives:
 - o positively charged donors.
 - o negatively charged free electrons.
5. Supply of energy gives:
 - o negatively charged free electrons.
 - o positively charged holes.

P-type (e.g. doped with Boron)

These are materials which have **Trivalent** impurity atoms (Acceptors) added and conduct by “hole” movement and are therefore called, **P-type Semiconductors**.

In these types of materials are:

- 1. The Acceptors are negatively charged.
- 2. There are a large number of holes.
- 3. A small number of free electrons in relation to the number of holes.
- 4. Doping gives:
 - negatively charged acceptors.
 - positively charged holes.
- 5. Supply of energy gives:
 - positively charged holes.
 - negatively charged free electrons.

and both P and N-types as a whole, are electrically neutral on their own.

Antimony (Sb) and Boron (B) are two of the most commonly used doping agents as they are more feely available compared to other types of materials. They are also classed as “metalloids”. However, the periodic table groups together a number of other different chemical elements all with either three, or five electrons in their outermost orbital shell making them suitable as a doping material.

These other chemical elements can also be used as doping agents to a base material of either Silicon (Si) or Germanium (Ge) to produce different types of basic semiconductor materials for use in electronic semiconductor components, microprocessor and solar cell applications. These additional semiconductor materials are given below.

Periodic Table of Semiconductors

Elements Group 13	Elements Group 14	Group	Elements Group 15
3-Electrons in Outer Shell (Positively Charged)	4-Electrons in Outer Shell (Neutrally Charged)	in	5-Electrons in Outer Shell (Negatively Charged)
(5) Boron (B)	(6) Carbon (C)		
(13) Aluminium (Al)	(14) Silicon (Si)		(15) Phosphorus (P)
(31) Gallium (Ga)	(32) Germanium (Ge)		(33) Arsenic (As)
			(51) Antimony (Sb)

In the next tutorial about semiconductors and diodes, we will look at joining the two semiconductor basics materials, the P-type and the N-type materials to form a PN Junction which can be used to produce diodes.

PN Junction Theory

In the above we saw how to make an N-type semiconductor material by doping a silicon atom with small amounts of Antimony and also how to make a P-type semiconductor material by doping another silicon atom with Boron.

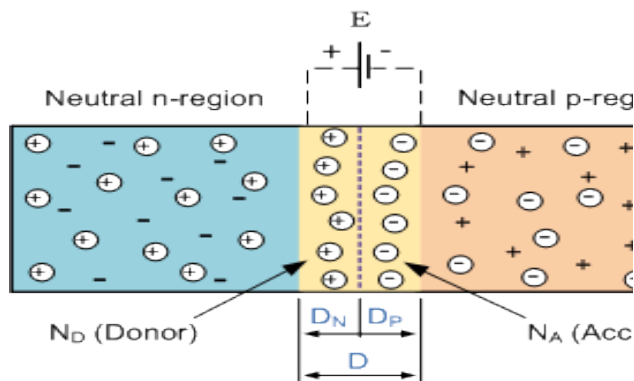

This is all well and good, but these newly doped N-type and P-type semiconductor materials do very little on their own as they are electrically neutral. However, if we join (or fuse) these two semiconductor materials together they behave in a very different way merging together and producing what is generally known as a “**PN Junction**”.

When the N-type semiconductor and P-type semiconductor materials are first joined together a very large density gradient exists between both sides of the PN junction. The result is that some of the free electrons from the donor impurity atoms begin to migrate across this newly formed junction to fill up the holes in the P-type material producing negative ions.

However, because the electrons have moved across the PN junction from the N-type silicon to the P-type silicon, they leave behind positively charged donor ions (N_D) on the

negative side and now the holes from the acceptor impurity migrate across the junction in the opposite direction into the region where there are large numbers of free electrons.

Related Products:

As a result, the charge density of the P-type along the junction is filled with negatively charged acceptor ions (N_A), and the charge density of the N-type along the junction becomes positive. This charge transfer of electrons and holes across the PN junction is known as **diffusion**. The width of these P and N layers depends on how heavily each side is doped with acceptor density N_A , and donor density N_D , respectively.

This process continues back and forth until the number of electrons which have crossed the junction

have a large enough electrical charge to repel or prevent any more charge carriers from crossing over the junction. Eventually a state of equilibrium (electrically neutral situation) will occur producing a “potential barrier” zone around the area of the junction as the donor atoms repel the holes and the acceptor atoms repel the electrons.

Since no free charge carriers can rest in a position where there is a potential barrier, the regions on either sides of the junction now become completely depleted of any more free carriers in comparison to the N and P type materials further away from the junction. This area around the **PN Junction** is now called the **Depletion Layer**.

N junction

The total charge on each side of a *PN Junction* must be equal and opposite to maintain a neutral charge condition around the junction. If the depletion layer region has a distance D , it therefore must therefore

penetrate into the silicon by a distance of D_p for the positive side, and a distance of D_n for the negative side giving a relationship between the two of $D_p \cdot N_A = D_n \cdot N_D$ in order to maintain charge neutrality also called equilibrium.

PN Junction Distance

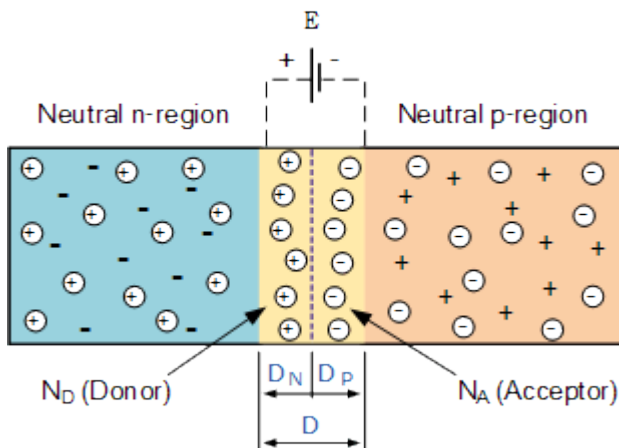

As the N-type material has lost electrons and the P-type has lost holes, the N-type material has become positive with respect to the P-type. Then the presence of impurity ions on both sides of the junction cause an electric field to be established across this region with the N-side at a positive voltage relative to the P-side. The problem now is that a free charge requires some extra energy to overcome the barrier that now exists for it to be able to cross the depletion region junction.

This electric field created by the diffusion process has created a “built-in potential difference” across the junction with an open-circuit (zero bias) potential of:

$$E_0 = V_T \ln \left(\frac{N_D \cdot N_A}{n_i^2} \right)$$

Where: E_0 is the zero bias junction voltage, V_T the thermal voltage of 26mV at

room temperature, N_D and N_A are the impurity concentrations and n_i is the intrinsic concentration.

A suitable positive voltage (forward bias) applied between the two ends of the PN junction can supply the free electrons and holes with the extra energy. The external voltage required to overcome this potential barrier that now exists is very much dependent upon the type of semiconductor material used and its actual temperature.

Typically at room temperature the voltage across the depletion layer for silicon is about 0.6 – 0.7 volts and for germanium is about 0.3 – 0.35 volts. This potential barrier will always exist even if the device is not connected to any external power source, as seen in diodes.

The significance of this built-in potential across the junction, is that it opposes both the flow of holes and electrons across the junction and is why it is called the potential barrier. In practice, a **PN junction** is formed within a single crystal of material rather than just simply joining or fusing together two separate pieces.

The result of this process is that the PN junction has rectifying current–voltage (IV or I–V) characteristics. Electrical contacts are fused onto either side of the semiconductor to enable an electrical connection to be made to an external circuit. The resulting electronic device that has been made is commonly called a PN junction Diode or simply Signal Diode.

Then we have seen here that a PN junction can be made by joining or diffusing together differently doped semiconductor materials to produce an electronic device called a diode which can be used as the basic semiconductor structure of rectifiers, all types of transistors, LED’s, solar cells, and many more such solid state devices.

In the next tutorial about the PN junction, we will look at one of the most interesting applications of the **PN junction** is its use in circuits as a diode. By adding connections to each end of the P-type and the N-type materials we can produce a two terminal device called a PN junction Diode which can be biased by an external voltage to either block or allow the flow of current through it.

PN Junction Diode

The effect described in the above is achieved without any external voltage being applied to the actual PN junction resulting in the junction being in a state of equilibrium.

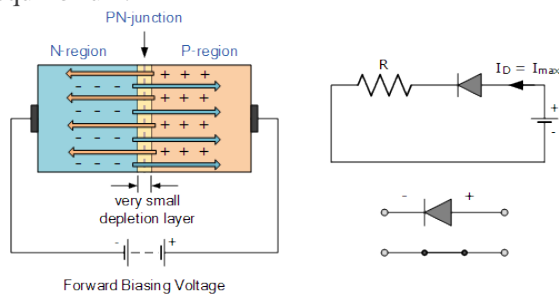

However, if we were to make electrical connections at the ends of both the N-type and the P-type materials and then connect them to a battery source, an additional energy source now exists to overcome the potential barrier.

The effect of adding this additional energy source results in the free electrons being able to cross the depletion region from one side to the other. The behaviour of the PN junction with regards to the potential barrier's width produces an asymmetrical conducting two terminal device, better known as the **PN Junction Diode**.

A *PN Junction Diode* is one of the simplest semiconductor devices around, and which has the characteristic of passing current in only one direction only. However, unlike a resistor, a diode does not behave linearly with respect to

the applied voltage as the diode has an exponential current-voltage ($I-V$) relationship and therefore we can not described its operation by simply using an equation such as Ohm's law.

If a suitable positive voltage (forward bias) is applied between the two ends of the PN junction, it can supply free electrons and holes with the extra energy they require to cross the junction as the width of the depletion layer around the PN junction is decreased.

Related Products:PIN

By applying a negative voltage (reverse bias) results in the free charges being pulled away from the junction resulting in the depletion layer width being increased. This has the effect of increasing or decreasing the effective resistance of the junction itself allowing or blocking current flow through the diode.

Then the depletion layer widens with an increase in the application of a reverse voltage and narrows with an increase in the application of a forward voltage. This is due to the differences in the electrical properties on the two sides of the PN junction resulting in physical changes taking place. One of the results produces rectification as seen in the PN junction diodes static $I-V$ (current-voltage) characteristics. Rectification is shown by an asymmetrical current flow when the polarity of bias voltage is altered as shown below.

Junction Diode Symbol and Static I-V Characteristics

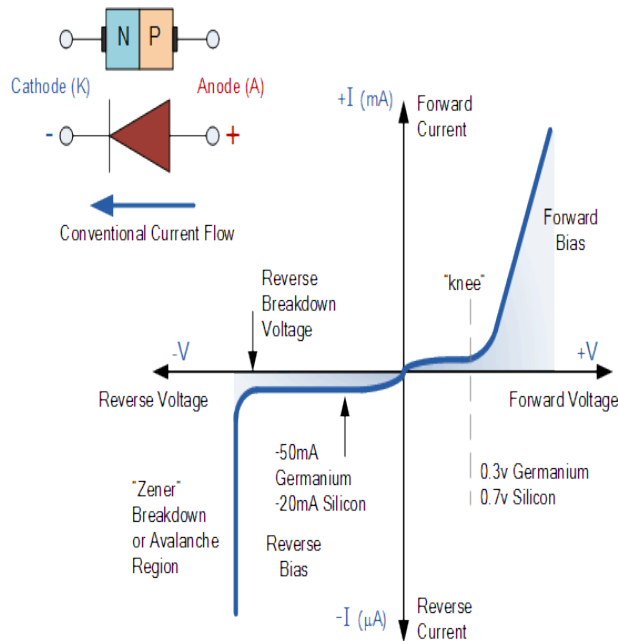

But before we can use the PN junction as a practical device or as a rectifying device we need to firstly **bias** the junction, ie connect a voltage potential across it. On the voltage axis above, “Reverse Bias” refers to an external voltage potential which increases the potential barrier. An external voltage which decreases the potential barrier is said to act in the “Forward Bias” direction.

There are two operating regions and three possible “biasing” conditions for the standard **Junction Diode** and these are:

- 1. Zero Bias – No external voltage potential is applied to the PN junction diode.
- 2. Reverse Bias – The voltage potential is connected negative, (-ve) to the P-type material and positive, (+ve) to the N-type material across the diode which has the effect of **Increasing** the PN junction diode’s width.
- 3. Forward Bias – The voltage potential is connected positive, (+ve) to the P-type material and negative, (-ve) to the N-type material across the diode which has the effect of **Decreasing** the PN junction diodes width.

Zero Biased Junction Diode

When a diode is connected in a **Zero Bias** condition, no external potential energy is applied to the PN junction. However if the diodes terminals are shorted together, a few holes (majority carriers) in the P-type material with enough energy to overcome the potential barrier will move across the junction against this barrier potential. This is known as the “**Forward Current**” and is referenced as I_F

Likewise, holes generated in the N-type material (minority carriers), find this situation favourable and move across the junction in the opposite direction. This is known as the “**Reverse Current**” and is referenced as I_R . This transfer of electrons and holes back and forth across the PN junction is known as diffusion, as shown below.

Zero Biased PN Junction Diode

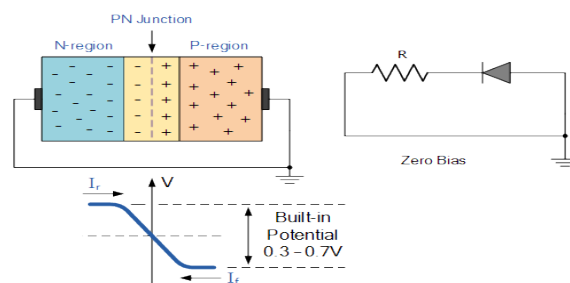

The potential barrier that now exists discourages the diffusion of any more majority carriers across the junction. However, the potential barrier helps minority carriers (few free electrons in the P-region and few holes in the N-region) to drift across the junction.

Then an “Equilibrium” or balance will be established when the majority carriers are equal and both moving in opposite directions, so that the net result is zero current flowing in the circuit. When this occurs the junction is said to be in a state of “**Dynamic Equilibrium**”.

The minority carriers are constantly generated due to thermal energy so this state of equilibrium can be broken by raising the temperature of the PN junction causing an increase in the generation of minority carriers, thereby resulting in an increase in leakage current but an electric current cannot flow since no circuit has been connected to the PN junction.

Reverse Biased PN Junction Diode

When a diode is connected in a **Reverse Bias** condition, a positive voltage is applied to the N-type material and a negative voltage is applied to the P-type material.

The positive voltage applied to the N-type material attracts electrons towards the positive electrode and away from the junction, while the holes in the P-type end are also attracted away from the junction towards the negative electrode.

The net result is that the depletion layer grows wider due to a lack of electrons and holes and presents a high impedance path, almost an insulator. The result is that a high potential barrier is created thus preventing current from flowing through the semiconductor material.

Increase in the Depletion Layer due to Reverse Bias

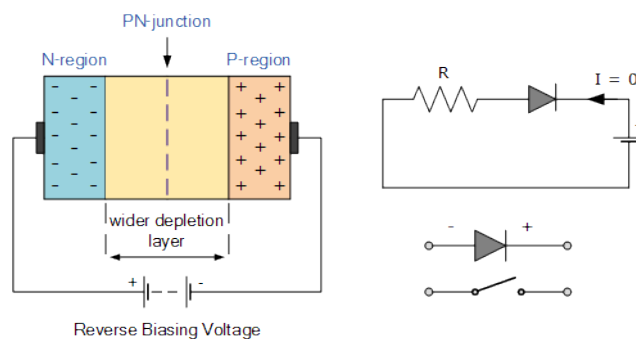

This condition represents a high resistance value to the PN junction and practically zero current flows through the junction diode with an increase in bias voltage. However, a very small **leakage current** does flow through the junction which can be measured in micro-amperes, (μA).

One final point, if the reverse bias voltage V_r applied to the diode is increased to a sufficiently high enough value, it will cause the diode's PN junction to overheat and fail due to the avalanche effect around the junction. This may cause the diode to become shorted and will result in the flow of maximum circuit current, and this shown as a step downward slope in the reverse static characteristics curve below.

Reverse Characteristics Curve for a Junction Diode

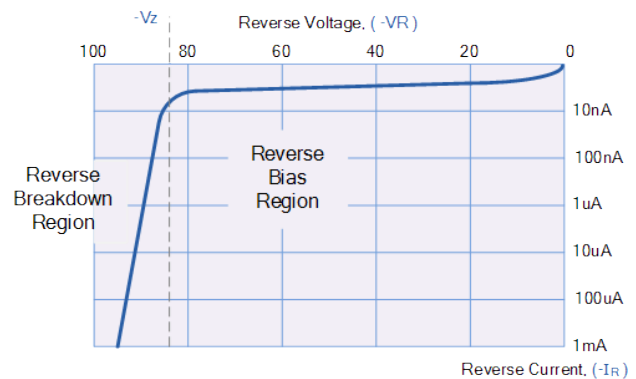

Sometimes this avalanche effect has practical applications in voltage stabilising circuits where a series limiting resistor is used with the diode to limit this reverse breakdown current to a preset maximum value thereby producing a fixed voltage output across the diode. These types of diodes are commonly known a Zener Diode and are discussed in a later tutorial.

Forward Biased PN Junction Diode

When a diode is connected in a **Forward Bias** condition, a negative voltage is applied to the N-type material and a positive voltage is applied to the P-type material. If this external voltage becomes greater than the value of the potential barrier, approx. 0.7 volts for silicon and 0.3 volts for germanium, the potential barriers opposition will be overcome and current will start to flow.

This is because the negative voltage pushes or repels electrons towards the junction giving them the energy to cross over and combine with the holes being pushed in the opposite direction towards the junction by the positive voltage. This results in a characteristics curve of zero current flowing up to this voltage point, called the “knee” on the static curves and then a high current flow through the diode with little increase in the external voltage as shown below.

Forward Characteristics Curve for a Junction Diode

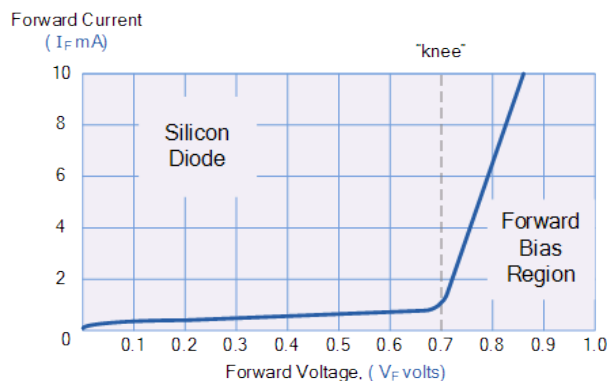

The application of a forward biasing voltage on the junction diode results in the depletion layer becoming very thin and narrow which represents a low impedance path through the junction thereby allowing high currents to flow. The point at which this sudden increase in current takes place is represented on the static I-V characteristics curve above as the “knee” point.

Reduction in the Depletion Layer due to Forward Bias

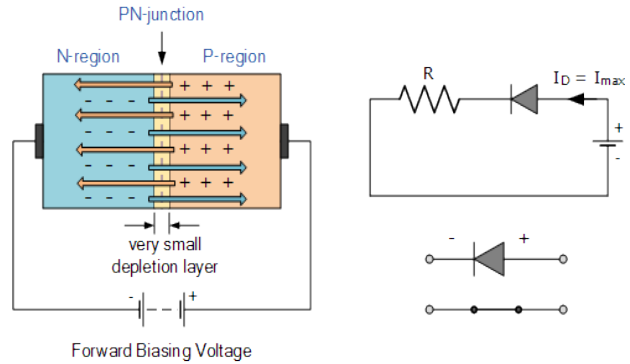

This condition represents the low resistance path through the PN junction allowing very large currents to flow through the diode with only a small increase in bias voltage. The actual potential difference across the junction or diode is kept constant by the action of the depletion layer at approximately 0.3v for germanium and approximately 0.7v for silicon junction diodes.

Since the diode can conduct “infinite” current above this knee point as it effectively becomes a short circuit, therefore resistors are used in series with the diode to limit its current flow. Exceeding its maximum forward current specification causes the device to dissipate more power in the form of heat than it was designed for resulting in a very quick failure of the device.

Junction Diode Summary

The PN junction region of a **Junction Diode** has the following important characteristics:

- Semiconductors contain two types of mobile charge carriers, **Holes** and **Electrons**.
- The holes are positively charged while the electrons negatively charged.
- A semiconductor may be doped with donor impurities such as Antimony (N-type

doping), so that it contains mobile charges which are primarily electrons.

- A semiconductor may be doped with acceptor impurities such as Boron (P-type doping), so that it contains mobile charges which are mainly holes.
- The junction region itself has no charge carriers and is known as the depletion region.
- The junction (depletion) region has a physical thickness that varies with the applied voltage.
- When a diode is **Zero Biased** no external energy source is applied and a natural **Potential Barrier** is developed across a depletion layer which is approximately 0.5 to 0.7v for silicon diodes and approximately 0.3 of a volt for germanium diodes.
- When a junction diode is **Forward Biased** the thickness of the depletion region reduces and the diode acts like a short circuit allowing full current to flow.
- When a junction diode is **Reverse Biased** the thickness of the depletion region increases and the diode acts like an open circuit blocking any current flow, (only a very small leakage current).

We have also seen above that the diode is two terminal non-linear device whose I-V characteristic are polarity dependent as depending upon the polarity of the applied voltage, V_D the diode is either *Forward Biased*, $V_D > 0$ or *Reverse Biased*, $V_D < 0$. Either way we can model these current-voltage characteristics for both an ideal diode and for a real diode.

Junction Diode Ideal and Real Characteristics

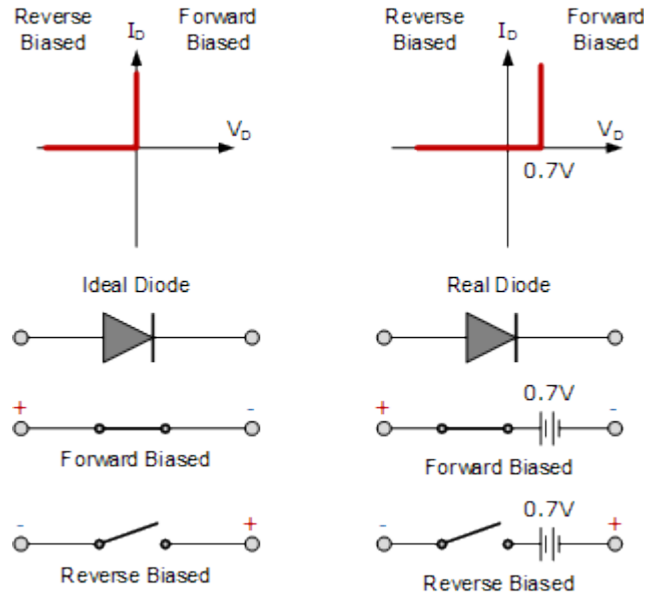

In the next tutorial about diodes, we will look at the small signal diode sometimes called a switching diode which is used in general electronic circuits. As its name implies, the signal diode is designed for low-voltage or high frequency signal applications such as in radio or digital switching circuits.

Signal diodes, such as the 1N4148 only pass very small electrical currents as opposed to the high-current mains rectification diodes in which silicon diodes are usually used. Also in the next tutorial we will examine the Signal Diode static current-voltage characteristics curve and parameters.

The PN junction diode has the following important applications are given below,

- PN junction diode is used as a voltage doubler, tripler, quadrupler in voltage multiplier circuits.
- It is used as a rectifier in DC power supply.
- In forward biased condition the PN junction diode produced light when biased with a current, so it is used in all LED lighting.
- In computers it is used as switch in logic circuits.
- In clipping and clapping circuits it is used for wave shaping.
- The PN junction diode used as signal diode in communication circuits.



- In demodulation circuits the PN junction diode used as a detector.
- Used as zener diodes in voltage stabilizing circuits.
- The PN junction diode used as varactor diodes for use in voltage controlled tuning circuits as may be found in radio and TV receivers

Conclusion

In this paper , you learned the relation between applied bias of a diode and its current. In a simple resistance, the rate between an applied voltage (forward or reverse) and yielding current is constant, which is the resistance of the element. However, for a diode, it varies with applied voltage. This property, also called dynamic resistance, is observed during this experiment. In reverse biasing, you measured a small saturation current. Saturation current exists whenever diode is reverse biased in between breakdown voltage and zero

References

- [1] The Physics of Information Technology, Neil Gershenfeld, Cambridge University Press (2000)
- [2] Electronics and Communications for Scientist and Engineers, Martin Plonus, Harcourt Academic Press (2010)
- [3] Introduction to Electrodynamics, 3rd edition, David J. Griffiths, Prentice Hall (2015)
- E. Cortina; modified by A. Sfyrla University of Geneva TPA-Electronique
- [4] The Art of Electronics, 2nd edition, P. Horowitz, W. Hill, Cambridge University Press (1989)
- [5] Engineer Mathematics, A. Croft, R. Davison, M. Hargreaves, Prentice Hall (2001)
- [6] The Physics of Particle Accelerators, K. Wille, Oxford Univ. Press)

[7] Foundations of Electronic Circuits and Devices, R.L. Meade, R. Diffenderfer, Ed. Thomson

Delmar Learning

[8] <http://en.wikipedia.org>