

# Renewable Energies Which Converts Low-Voltage Degree to High-Voltage Level Strength

I. B.VANDANASIRI

ASSISTANT PROFESSOR

KAKATIYA UNIVERSITY COLLEGE OF ENGINEERING AND TECHNOLOGY,GUNDLA SINGARAM,MUCHERLA NAGARAM  
ROAD,WARANGAL – 506009,TS – INDIA

**ABSTRACT:-** This paper proposed to construct an shape which includes Electric Double-Layer Capacitors (EDLCs) and lithium-ion capacitors via the use of the usage of the subsequent components assembled into the shape: i) double-switch cell voltage equalizer using a parallel-resonant-inverter (PRI) or collection-parallel-resonant inverters; ii) voltage multiplier. The easy circuit of double-transfer operation, which doesn't have multi-winding transformer, is positive in modularity and circuitry than classical model of equalizers, which calls for multi-winding transformer and a multiple switches. The proposed equalizer model can function at voltage diploma 0 V, accurately, as an opportunity then the traits the PRI/SPRI's inherent constant modern-day, at a difficult and speedy frequency will gets rid of the feedback control to restriction currents underneath desired stages. This method is nearly demonstrated within the laboratories, through manner of the use of a 10W version for 12 cells connected in collection modified into constructed, and equalization take a look at turned into completed on EDLCs from an initially voltage imbalanced scenario. The equalizer removed efficaciously of the voltage discrepancies in collection-linked EDLCs, and showed the equalization performance. The proposed equalizer changed into mathematically. A detailed operation analyses have been executed one after the opposite for the voltage multiplier and PRI/SPRI and acquired a dc equal circuit for the proposed equalizer.

Keywords: - Parallel-resonant-inverter (PRI), equalizer, series-linked EDLC, voltage imbalance, voltage equalizer, multi-winding.

## 1. INTRODUCTION

Auxiliary garage battery technologies are the maximum growing generation; this is gambling a critical function in electricity garage gadget inclusive of electrical vehicles, renewable strength structures, transportable digital devices, and so forth. Among these sources, lithium-ion batteries

providing the exceptional strength and the location of that secondary battery technology are rapidly developing [3]. Here on this paper, the proposed hybrid-capacitors (HCs) having the blessings of conventional and EDLCs and lithium-ion batteries. The super capacitors [6], including electric powered double-layer capacitors (EDLCs) and lithium-ion capacitors combined and customary a hybrid capacitor. Hybrid capacitor strength gadget is more high quality than the traditional secondary batteries garage in terms of temperature reputation, provider lifestyles of the battery, and electricity abilities. The super capacitors are utilized in high-electricity programs as power buffers in balancing secondary batteries. There has been present system research to accumulate the better precise energy and longer provider existence of SCs. If we accumulate the above competencies in SCs, then becomes capability opportunity power garage supply. In series related power garage cells the prevalence of voltage imbalances leads to overcharging and over discharging of cells in the storage [1]. These imbalances are because of the most charged and least charged cells, in terms of the individual residences of the cells together with capacitance, internal impedance, self-discharge. In order to decide a purpose cell-the least or maximum-charged mobile-for the equalizer to execute equalization we need to incorporate a shrewd manage device [4]. To make certain the carrier lifestyles of the battery cells, it's far critical of mobile voltage equalization. Since, there are large range of mobile voltage equalization strategies had been supplied, tested and applied for incredible capacitors and lithium-ion batteries. For building those equalizers, we use more than one bidirectional dc-dc converters. This has the circuit complexity downside in series of connections. In an application like electric powered automobile, voltage equalizers primarily based on an unmarried remoted converter and choice switches [5]. When simple circuitry is preferred, we want the ones equalizers. There is every different configuration of equalizers with fewer switches and passive components the usage of multi winding transformers, and moreover single-switch unmarried-transformer equalizers and equalization chargers the usage of voltage multipliers was proposed.

In this paper, we suggest, a double-transfer equalizer using a parallel-resonant inverter or collection-parallel-resonant inverter and voltage multiplier for collection-related amazing capacitors.

## 2. IMPLEMENTATION

To assemble the proposed equalizer, we need a combination of PRI/SPRI and a voltage multiplier. On this the double-switch shape doesn't have the multi-winding transformer, which offers simplified circuit, so the equalizer can characteristic effectively at even SC voltage is zero V. This equalizer is suitable not simplest as an equalizer for series-linked lithium-ion batteries however additionally for first-rate capacitors. This assignment is discussed within the following way of techniques:

a) The description of circuit definition and structural configuration of proposed equalizer.

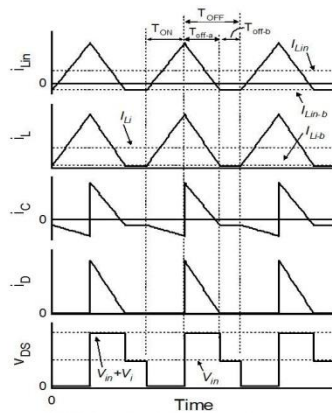
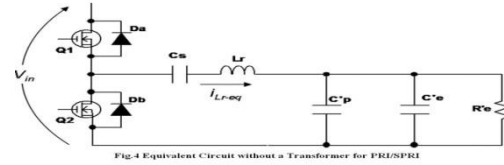
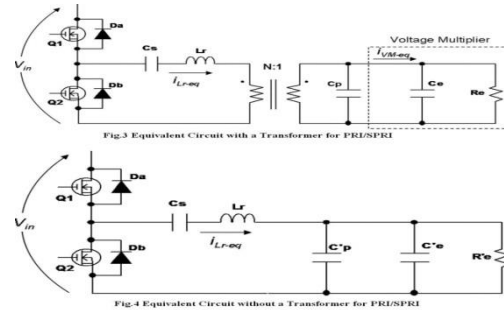
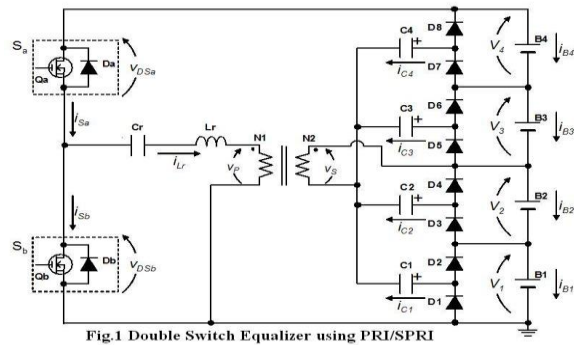

B) The evaluation of voltage multiplier and PRI/SPRI system.

C) Designing of PRI, with an example.

D) Simulations of equalizers.

E) Conducting experimental identical-inaction check on series-linked EDLCs with 10W prototype using a PRI for 12 cells linked in collection.

F) The summarization of essential capabilities of the proposed equalizer.

### SIMULATION RESULTS:

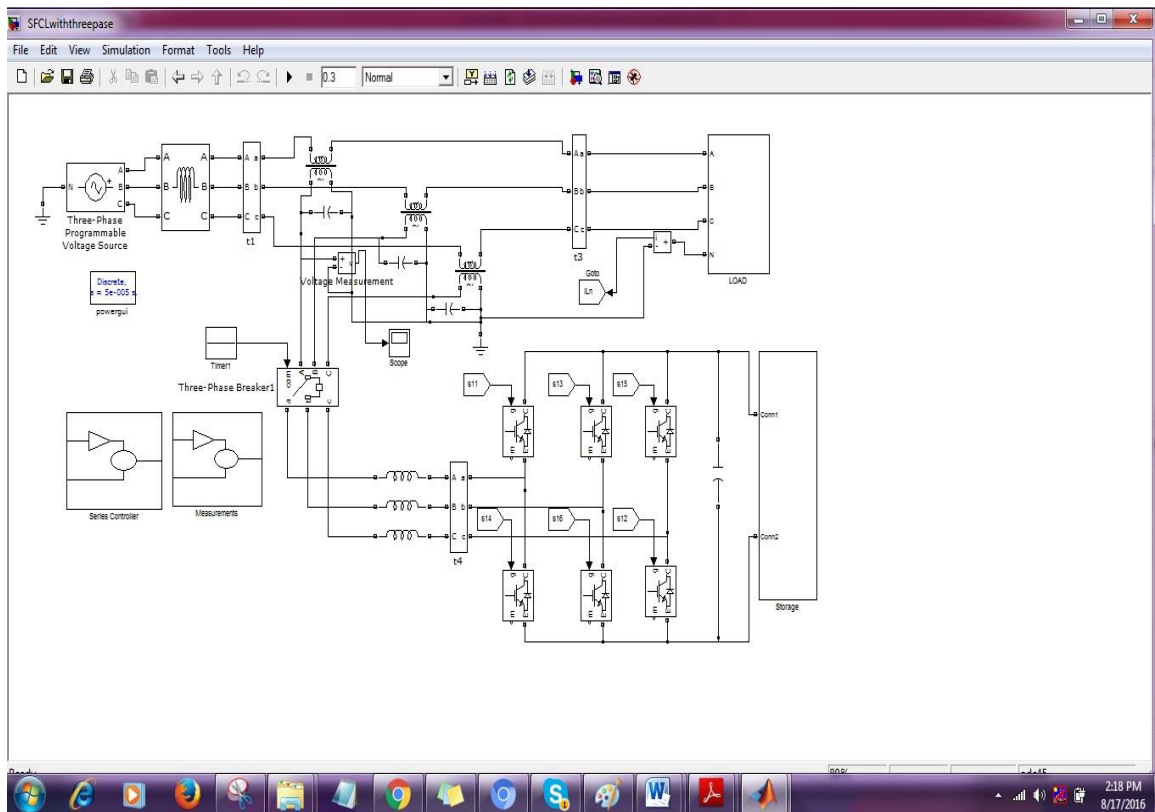

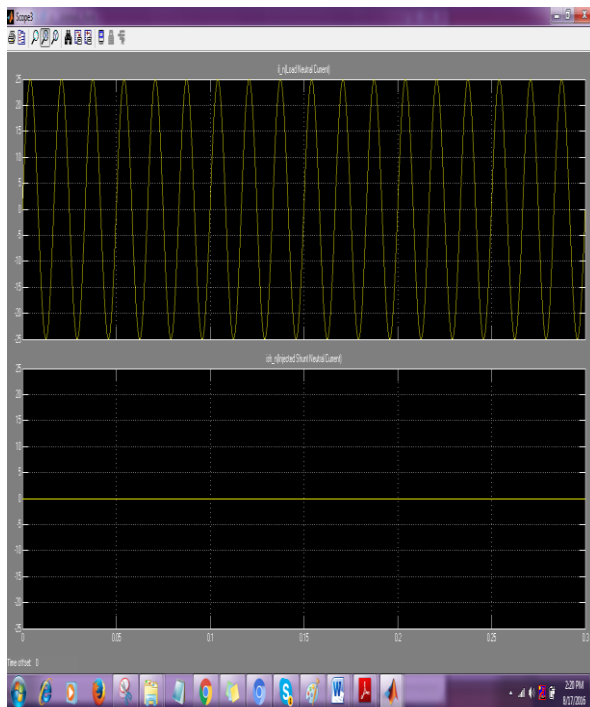
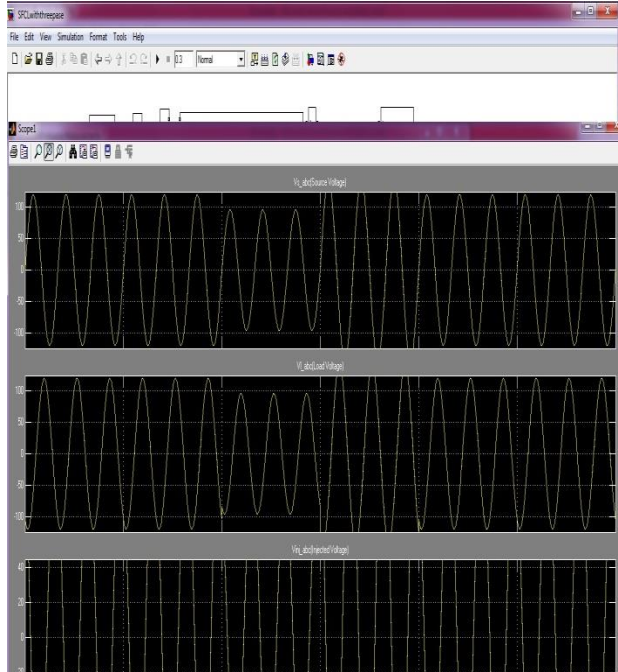

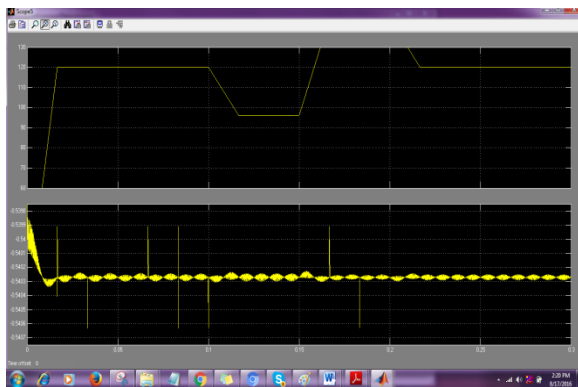
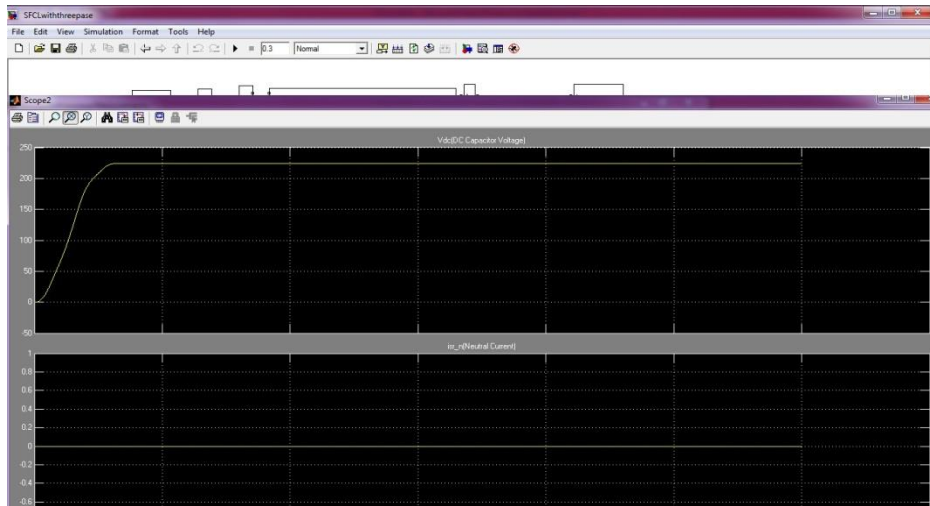

## CONCLUSION

In this paper we proposed a double-switch mobile voltage equalizer, to assemble the proposed equalizer; we need an aggregate of PRI/SPRI and a voltage multiplier. On this the double-switch shape doesn't have the multi-winding transformer, which gives simplified circuit, so the equalizer can perform well at even, SC voltage is 0 V. Due to the natural houses of PRI/SPRI's

receives rid of the need or remarks manipulate to restriction currents under sure stages at a difficult and fast frequency.

Dc circuits of voltage multiplier and PRI/SPRI were derived by way of the usage of combining the identical circuits from the discrete mathematic assessment. 10W hardware circuit of the proposed equalizer for 12 cells linked in series changed into made for experiments, which might be performed in initially imbalanced voltage conditions of collection-linked EDLCs.

At the give up of the experiments, it was set up the equalization overall performance of the equalizer, voltage imbalance changed into step by step decreased, and in the end significant deviations of cellular voltages decreases low sufficient

## REFERENCES

- [1] M. Y. Kim, J. W. Kim, C. H. Kim, S. Y. Cho, and. W.Moon, “Automatic charge equalization circuit based on regulated voltage source for series connected lithium-ion battery,” in *Proc. 8th Int. Conf. Power Electron. ECCE Asia*, Jun. 2011, pp. 2248–2255.
- [2] Y. S. Lee and M. W. Cheng, “Intelligent control battery equalization for series connected lithium-ion battery strings,” *IEEE Trans. Ind. Electron.*, vol. 52, no. 5, pp. 1297–1307, Oct. 2005.
- [3] C. Pascal and P. T. Rein, “Switched capacitor system for automatic series battery equalization,” in *Proc. IEEE Appl. Power Electron. Conf. Expo.*, Feb. 1997, pp. 848–854.
- [4] N. H. Kutkut, H. L. N. Wiegman, D. M. Divan, and D. W. Novotny, “Design considerations for charge equalization of an electric vehicle battery system,” *IEEE Trans. Ind. Appl.*, vol. 35, no. 1, pp. 28–35, Jan. 1999.

- [5] M. Uno and K. Tanaka, “Accelerated charge-discharge cycling test and cycle life prediction model for supercapacitors in alternative battery applications,” *IEEE Trans. Ind. Electron.*, vol. 59, no. 12, pp. 4704–4712, Dec. 2012.
- [6] R. Lu, C. Zhu, L. Tian, and Q. Wang, “Super-capacitor stacks management system with dynamic equalization techniques,” *IEEE Trans. Magnetics*, vol. 43, no. 1, pp. 254–258, Jan. 2007.