

Power quality improvement of DSTATCOM under different loading conditions

K.Naga Raju & B Ramesh Babu

Assistant Professor Department of Electrical & Electronics Engineering, Geethanjali College of engineering and technology, cheeryal, Medchal (DT); Telangana, India.

Abstract: *The Distribution Static Compensator (DSTATCOM) is most effective device based on Voltage Source Converter (VSC). STATCOM is usually used in transmission system while D-STATCOM is used in distribution system however it's called as the Distribution Static Compensator (DSTATCOM). D-STATCOM is utilizes power electronics to solve many power quality issues by distributed system. DSTATCOM used to improve the voltage regulation, load balancing, power factor correction and harmonics etc. Distribution static compensator (DSTATCOM) is very popular in compensating the linear, nonlinear, balanced and unbalanced loads. Any change in the load affects the DC-link voltage (DCLV) directly. The proper operation of DSTATCOM requires variation of the DCLV within the prescribed limits. D-STATCOM has 3-phase voltage source converter, capacitor at DC side of inverter is connected with the electrical system at the PCC. The instantaneous controllable 3-phase output voltage is generated from DC voltage at fundamental frequency. The pulse is generated by the hysteresis current controller which takes the difference of reference current and actual source current and minimizes the error and controls the current and generates 3-phase output voltage and injects capacitive or inductive current according to the nature of load. The D-STATCOM performance can be analyzed under different loading conditions by using MATLAB /SIMULINK software.*

Key words: *D-STATCOM (Distributed Static Synchronous Compensator); different loading conditions; PI Controller; Hysteresis Current Control; Harmonic Distortion.*

I. INTRODUCTION

The term power quality is used in synonymous with supply reliability to indicate the existence of an adequate and secure power supply. Power quality is generally used to express the quality of the voltage. Power Generation, Transmission and Distribution is a difficult process, requiring the working of many components of the power system to maximize the quality of the output. The quality may be reduced by many factors such as Harmonics, reactive power, voltage sag, swell, and transients. Among all, the reactive power is the main component to decrease the quality of the waveform. So we need to compensate the reactive power. Reactive power is required to meet the inductive and capacitive loads. Most of the electrical loads are inductive; hence we need to compensate reactive power. The Reactive power

may be compensated in many ways including FACTS [1-2] controller, fixed capacitors and synchronous condensers etc. Nowadays, FACTS controllers are used for compensating the reactive power. Here distributed static synchronous compensator (DSTATCOM) is used to compensate the reactive power. DSTATCOM has many advantages than other FACTS controllers. The advantages of DSTATCOM [3-4] are compensating reactive power, and used for reducing the voltage drops improve the transfer capability of the power in the transmission and distribution lines. The advantages of reactive power compensation are improved power factor, voltage balancing, and improve system stability. So reactive power compensation is needed. The main objective of this work is to compensate the reactive power by using Id-Iq control method [5-6]. This method also maintains the voltage at the stability level and the real power also compensated by connecting the same setup in series compensation. The I_d - I_q control method is very easy to implement and it gives faster computation.

The causes of power quality problems are generally complex and difficult to detect [7]. Technically speaking, the ideal AC line supply by the utility system should be a pure sine wave of fundamental frequency (50/60Hz). Different power quality problems, their characterization methods and possible causes are discussed above and which are responsible for the lack of quality power which affects the customer in many ways. We can therefore conclude that the lack of quality power can cause loss of production, damage of equipment or appliances or can even be detrimental to human health. It is therefore imperative that a high standard of power quality is maintained. This project demonstrates that the power electronic based power conditioning using custom power devices like DSTATCOM [8] can be effectively utilized to improve the quality of power supplied to the customers.

D-STATCOM basically VSC based FACTS controller [9]. It is employed at distribution level or at load side also behaves as shunt active filter. It works as the IEEE-519 standard limit. Since the electrical power distribution system it is very important to balance the supply and demand of active and reactive power in the electrical power system. In case if the balance is lost the frequency and voltage excursion may occur result in collapse of power system. So we can say that the key of

stable power system. The distribution system losses power quality problems are increasing due to reactive power. The main application of D-statcom [10] exhibit high speed control of reactive power to provide voltage stabilization in power system. The D-statcom protect the distribution system from voltage sags, flicker caused by reactive current demand.

II. POWER QUALITY

Power quality deals with maintaining a pure sinusoidal waveform of voltage and frequency. Voltage quality concern with deviation of voltage from ideal voltage (sinusoidal) it is a single frequency sine wave at rated magnitude and frequency with no harmonics. Current quality is a complimentary term of voltage quality concern with a deviation from the ideal current. Current should be in phase with the voltage.

According to IEEE standard 1100, “power quality is the concept of powering and grounding sensitive equipment in a manner that is suitable to the operation of that equipment”.

a) Power quality problems

There are so many problems related with quality of power. Here the main concern with the poor power quality with nonlinear loads. Non-linear loads can cause voltage and current distortion. That is it changes its shape other than sinusoidal.

b) Harmonic Distortion

Harmonic components are those waveforms which have the frequency as an integer multiple of the fundamental. Any periodic waveform which is non-sinusoidal can be divided into fundamental and non-fundamental components. Every nth harmonic will have a frequency n times that of fundamental frequency.

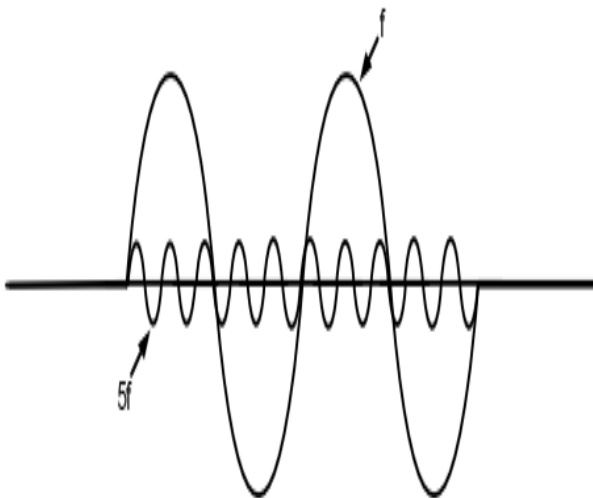

Figure.1: Fundamental component and 5th harmonic component

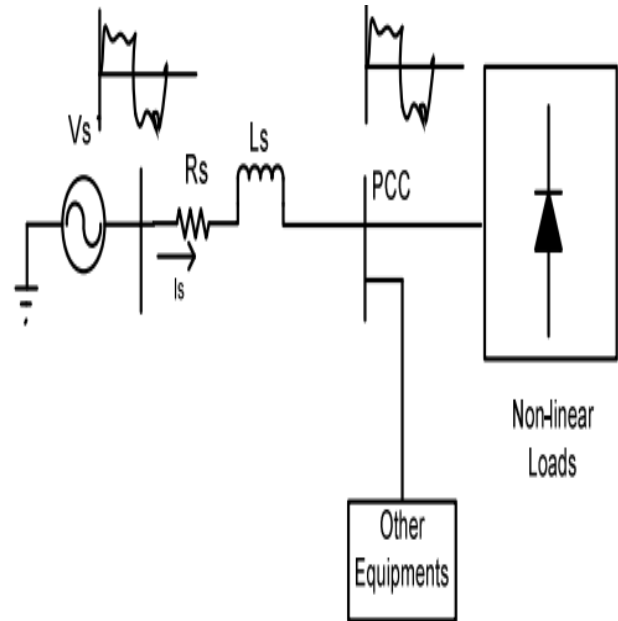

Figure.2: Power System with non-linear loads

Voltage at point of common coupling

$$V_{pcc} = V_s - L_{s1} \left(\frac{di_s}{dt} \right) \quad (1)$$

$$i_s = i_{s1} + \sum i_{sh} \quad (2)$$

$$V_{pcc} = \left(V_{sh} - L_{s1} \left(\frac{di_{s1}}{dt} \right) \right) - \left(L_{s1} - \left(\frac{di_{sh}}{dt} \right) \right) \quad (3)$$

$$V_{pcc} = V_{pcc1} - V_{pcc(\text{distortion})} \quad (4)$$

Where

$$V_{pcc1} = \left(V_{sh} - L_{s1} \left(\frac{di_{s1}}{dt} \right) \right)$$

$$V_{pcc(\text{distortion})} = \left(L_{s1} - \left(\frac{di_{sh}}{dt} \right) \right)$$

Non-linear loads draw reactive power. So input power factor is also get poor.

Line current and Total Harmonic Distortion (THD)

$$v_s = \sqrt{2} V_s \sin \omega t \quad (5)$$

$$i_s = \sqrt{2} I_{s1} \sin(\omega_1 t - \phi_1) + \sum \sqrt{2} I_{sh} \sin(\omega_n t - \phi_n) \quad (6)$$

$$i_s = i_{s1}(t) + \sum i_{sh}(t) \quad (7)$$

$$I_s = (I_{s1}^2 + \sum i_{sh}^2) \quad (8)$$

If we remove fundamental, then only ripple will be left

$$i_{\text{distortion}} = (i_s^2 - i_{s1}^2)^{\frac{1}{2}} = (\sum i_{sh}^2)^{\frac{1}{2}} \quad (9)$$

$$\%THD = I_{distortion} * \frac{100}{I_{sh}} \quad (10)$$

$$\%THD = \sqrt{I_s^2 - I_{s1}^2} * \frac{100}{I_{s1}} \quad (11)$$

III. PRINCIPLE OF D-STATCOM

It is shunt connected at the distribution side of the power systems. A D-STATCOM is a controlled reactive source, which includes a Voltage Source Converter (VSC) and a DC link capacitor connected in shunt, capable of generating and/or absorbing reactive power. The operating principles of a D-STATCOM are based on the exact equivalence of the conventional rotating synchronous compensator.

The AC terminals of the VSC are connected to the Point of Common Coupling (PCC) through an inductance, which could be a filter inductance or the leakage inductance of the coupling transformer, as shown in Figure 3. The DC side of the converter is connected to capacitor, which carries the input ripple current of the converter and reactive energy storage element. This capacitor could be charged by voltage source or inverter. When AC output voltage of inverter is equal to terminal voltage, then there is no reactive power exchange. If there is a difference between these voltages the only reactive power exchange occurs. The control strategies studied in this paper are applied with a view to studying the performance of a D-STATCOM for reactive power compensation and harmonic mitigation.

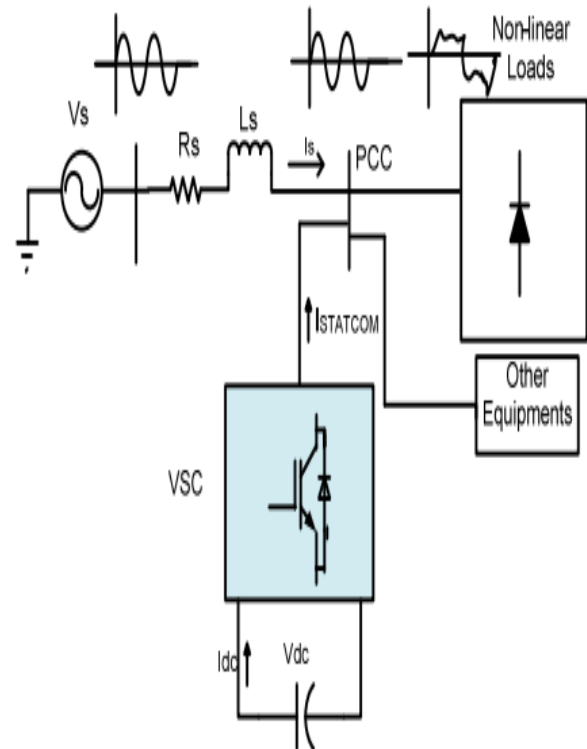

Figure.3: Power system with D-STATCOM

Configuration and operation of DSTATCOMD-STATCOM has 3-phase voltage source converter, capacitor at DC side of inverter is connected with the electrical system at the PCC. The instantaneous controllable 3-phase output voltage is generated from DC voltage at fundamental frequency. The pulse is generated by the hysteresis current controllers which takes the difference of reference current and actual source current and minimizes the error and controls the current and generate 3-phase output voltage and injects capacitive or inductive current according to the nature of load.

IV. MATHEMATICAL EXPRESSION FOR SYSTEM

Total instantaneous power delivery drawn by non-linear load

$$P_L(t) = P_{s1}(t) + P_r(t) + P_{sh}(t) \quad (12)$$

Real power supplied by source-

$$P_s = P_{s1} \quad (13)$$

Reactive power supplied by source-

$$Q_s = 0 \quad (14)$$

Real power drawn by the load-

$$P_L = P_{s1} + P_{sh} \quad (15)$$

Reactive power drawn by the load-

$$Q_L = Q_{s1} + Q_{sh} \quad (16)$$

Real power supplied by the D-STATCOM-

$$P_{STATCOM} = P_{sh} - P_{loss} \quad (17)$$

Reactive power supplied by D-STATCOM-

$$Q_{STATCOM} = Q_{s1} + Q_{sh} \quad (18)$$

Where P_{loss} component of STATCOM

From the single line diagram Figure 2

$$i_s(t) = i_L(t) + i_{STATCOM}(t) \quad (19)$$

When the phase of $V_{STATCOM}$ is in quadrature with $I_{STATCOM}$ without injecting real power the D-STATCOM can achieve the voltage sag mitigation. The shunt injecting current $I_{STATCOM}$ and 5 in Figure 3 can be expressed as equation (20 and 21)

$$I_{STATCOM} = I_L - I_s = I_L - \left(\frac{V_{th} - V_L}{Z_{th}}\right) \quad (20)$$

$$V_L = V_{th} + (I_{STATCOM} - I_L)Z_{th} \quad (21)$$

$$I_s = (V_{th} - V_L)/Z_{th} \quad (22)$$

Where

V. CONTROL STRATEGY

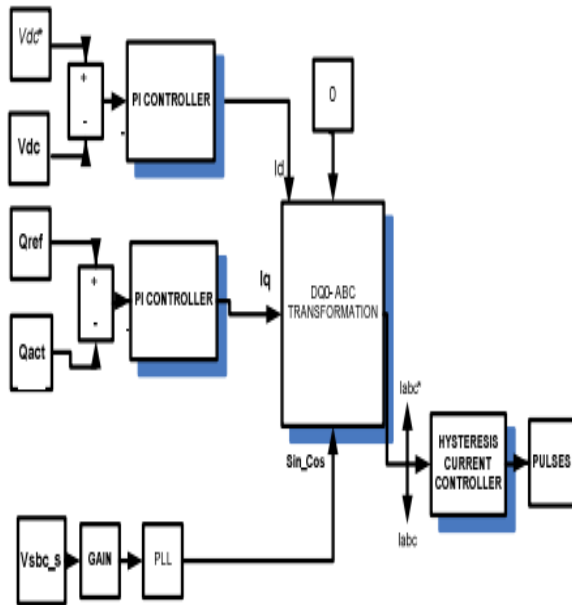

Figure.4: Control Strategy to generate pulses

VI. MATHEMATICAL MODELING

The direct and quadrature axis component of current are:

$$I_d = \left(K_p + \frac{Ki}{s}\right) * (V_{DC}^* - V_{DC}) \quad (23)$$

$$I_q = \left(K_p + \frac{Ki}{s}\right) * (Q_{grid}^* - Q_{grid}) \quad (24)$$

a) d-q-0 to a-b-c transformation

$$x_{abc} = K^{-1} x_{dq0}$$

$$= \sqrt{\frac{2}{3}} * \begin{bmatrix} \cos(\theta) & -\sin(\theta) & \frac{1}{\sqrt{2}} \\ \cos\left(\theta - \frac{2\pi}{3}\right) & -\sin\left(\theta - \frac{2\pi}{3}\right) & \frac{1}{\sqrt{2}} \\ \cos\left(\theta + \frac{2\pi}{3}\right) & -\sin\left(\theta + \frac{2\pi}{3}\right) & \frac{1}{\sqrt{2}} \end{bmatrix} \begin{bmatrix} x_d \\ x_q \\ x_0 \end{bmatrix} \quad (25)$$

b) Hysteresis Current Controller

In conventional hysteresis band (HB) current control, the switching signal is sent to the IGBT at the same arm (T1 and T4). The output of the HBC is directly connected to the transistor T1 and reverse is connected to the T4, therefore the transistor in the same leg is not simultaneously ON or OFF. IGBT are self commutated. Hysteresis Current Controller compares the actual and reference current and generates pulses for the inverter.

If

$$i \leq (i^* - HB), \text{ then T1 in ON} \quad (26)$$

If

$$i \geq (i^* + HB), \text{ then T4 is ON} \quad (27)$$

VII. MATLAB/SIMULATION RESULTS

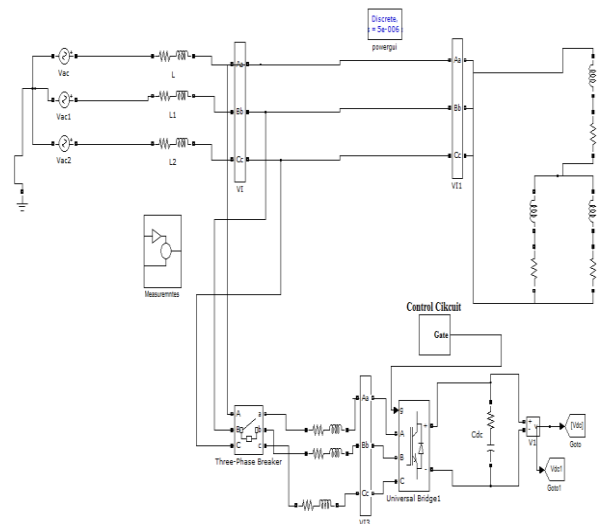

Fig.5 Power system with D-STATCOM

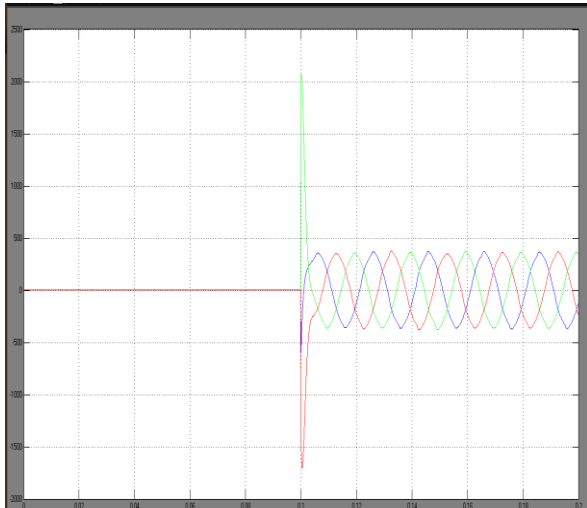

Fig.6 Grid reference current

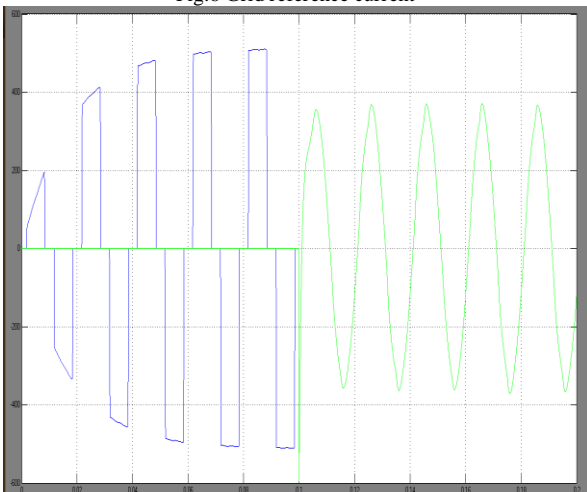

Fig.7 Grid phase and reference currents

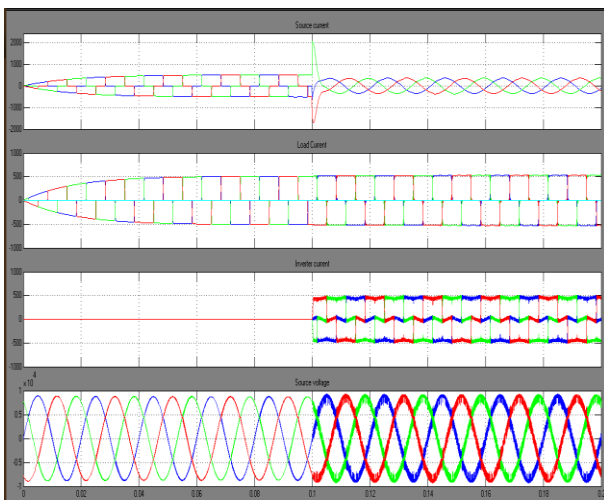

Fig.8 Source current, Load current, D-STATCOM injected harmonic current and Source voltage

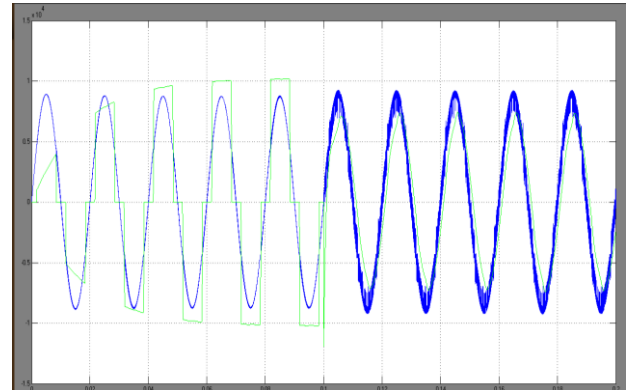

Fig.9 Power factor angle between source voltage and current

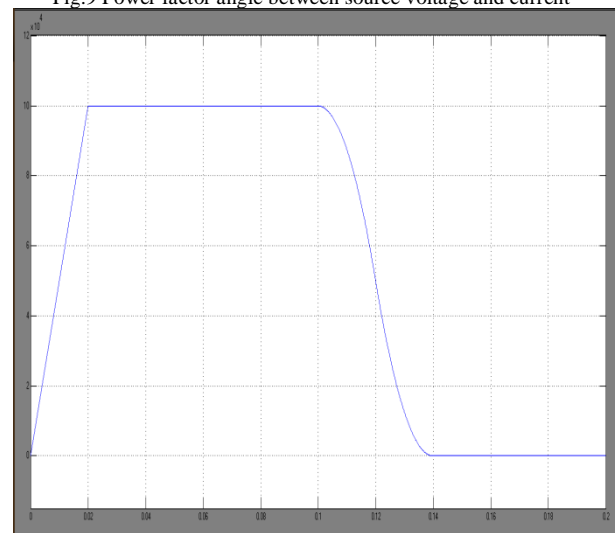

Fig.10 Reactive power generated by Grid

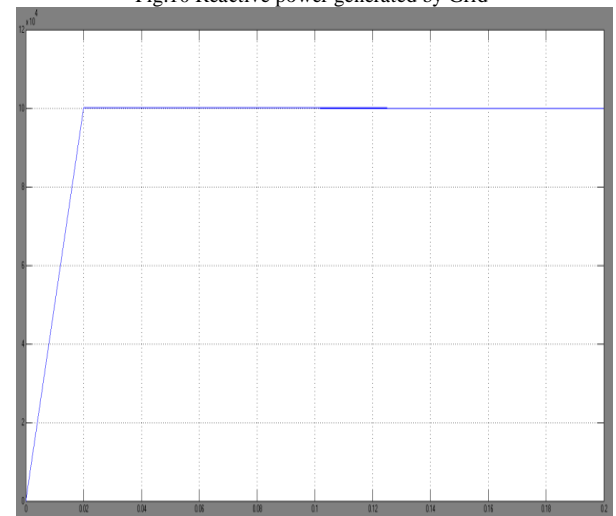

Fig.11 Reactive power demanded by load

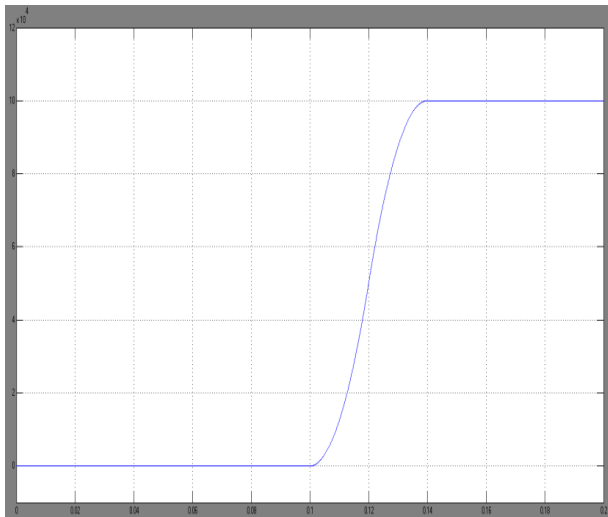

Fig.12 Reactive power supplied by D-STATCOM

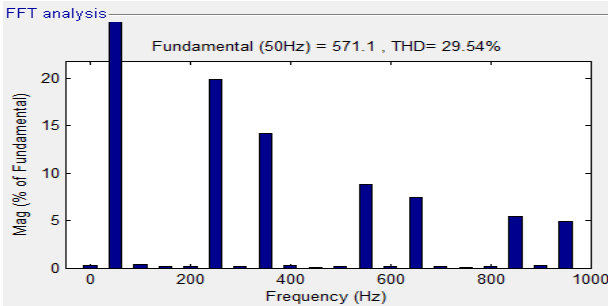
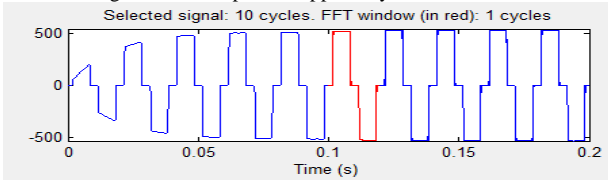

Fig.13 Load current THD

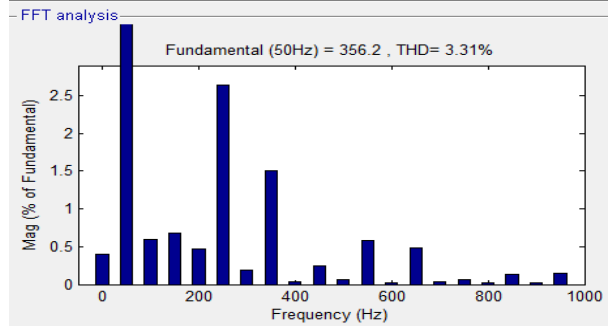
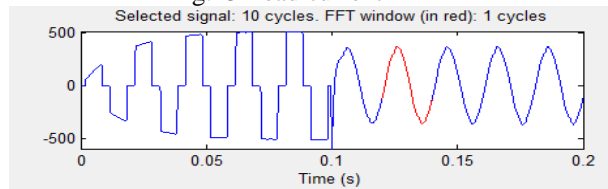

Fig.14 Source current THD

Case: 1 Balanced linear load

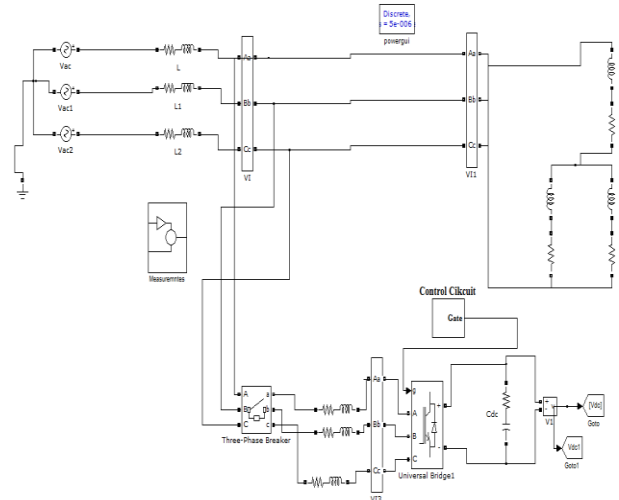

Fig.15 MATLAB/SIMULINK model of D-STATCOM with balanced linear loads

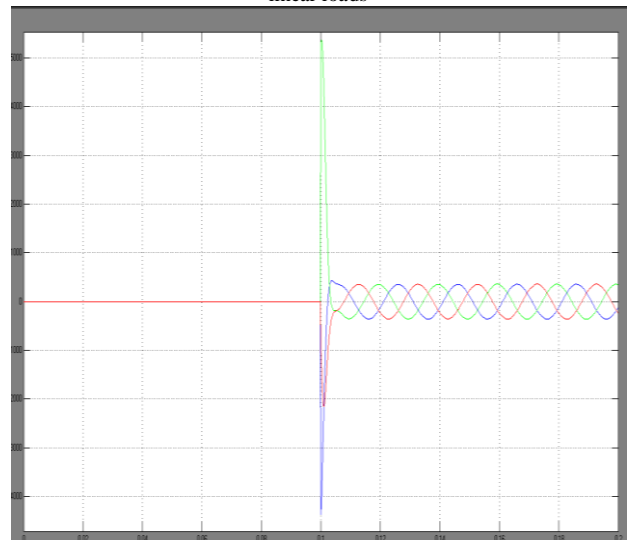

Fig.16 Grid reference current

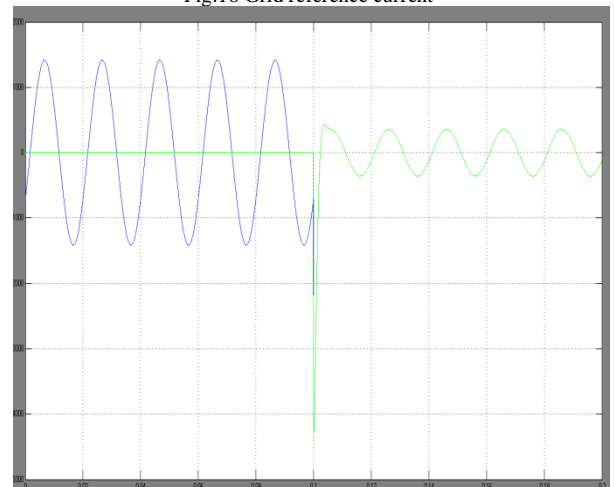

Fig.17 Grid phase and reference currents

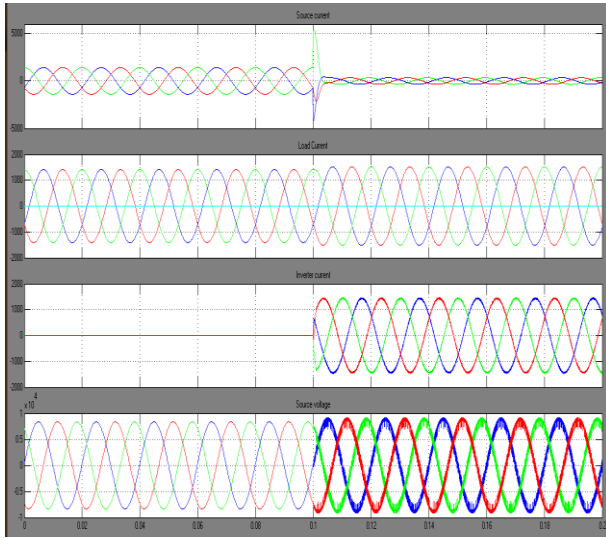

Fig.18 Source current, Load current, D-STATCOM injected harmonic current and Source voltage

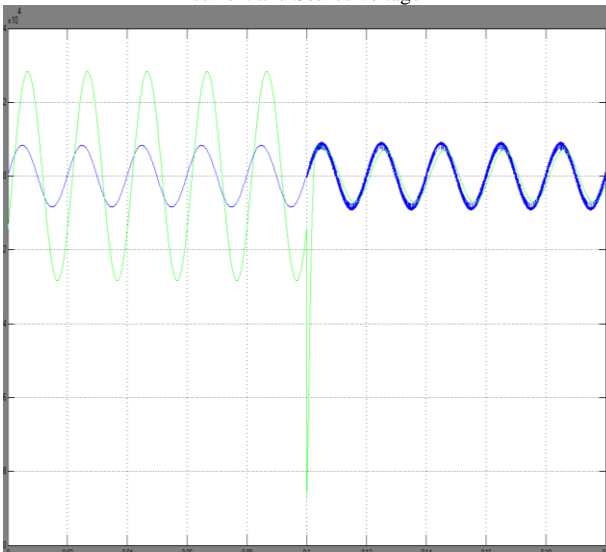

Fig.19 Power factor angle between source voltage and current

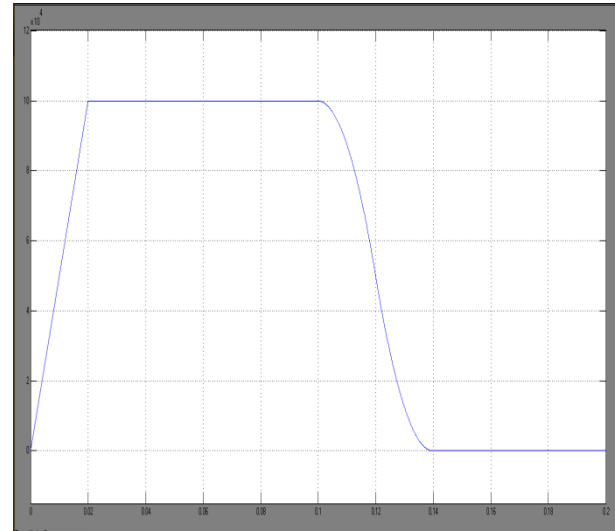

Fig.20 Reactive power generated by Grid

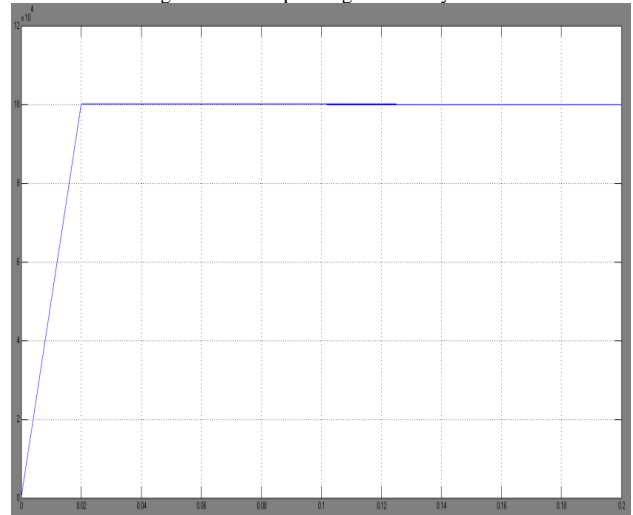

Fig.21 Reactive power demanded by load

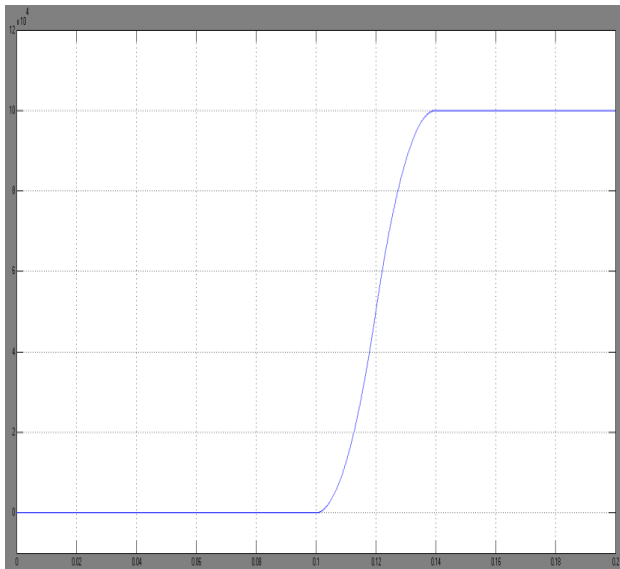

Fig.22 Reactive power supplied by D-STATCOM

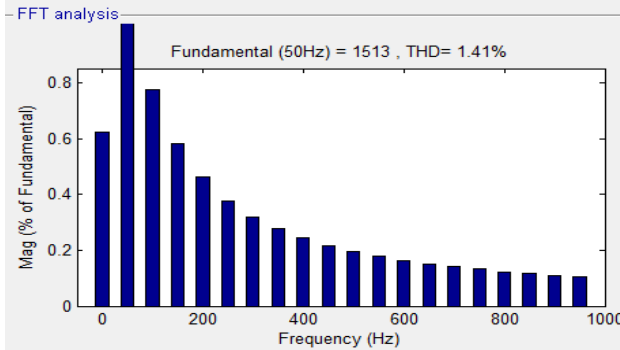
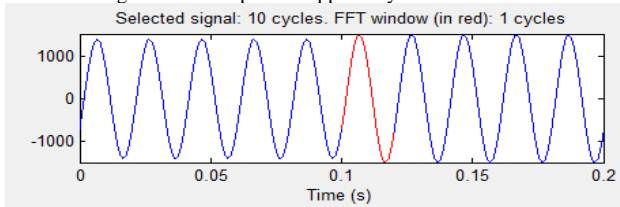

Fig.23 Load current THD

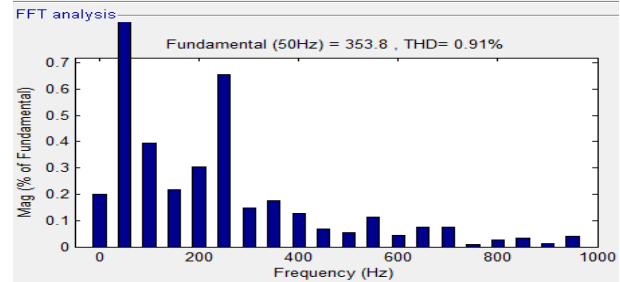
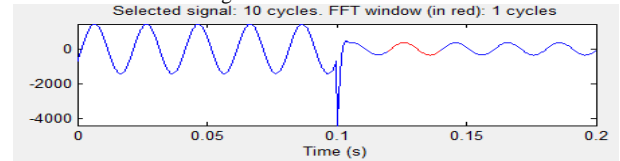

Fig.24 Source current THD

Case: 2 Balanced non-linear load

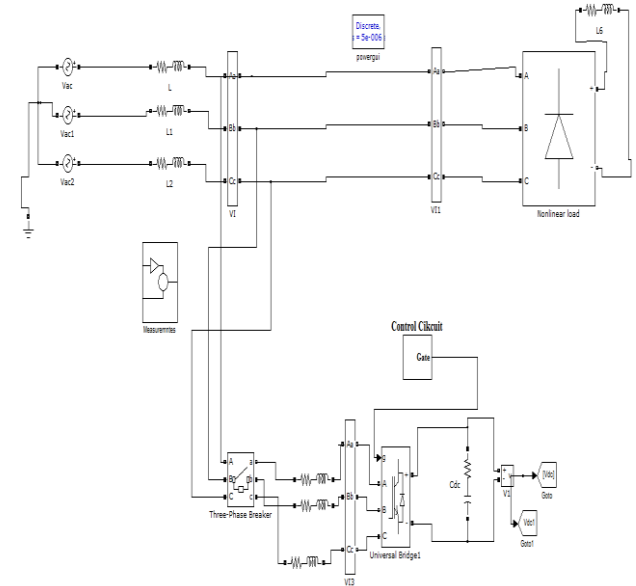

Fig.25 MATLAB/SIMULINK model of D-STATCOM with balanced non-linear loads

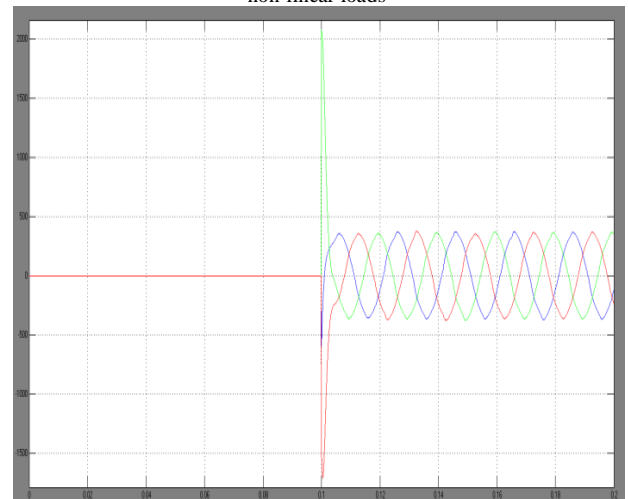

Fig.26 Grid reference current

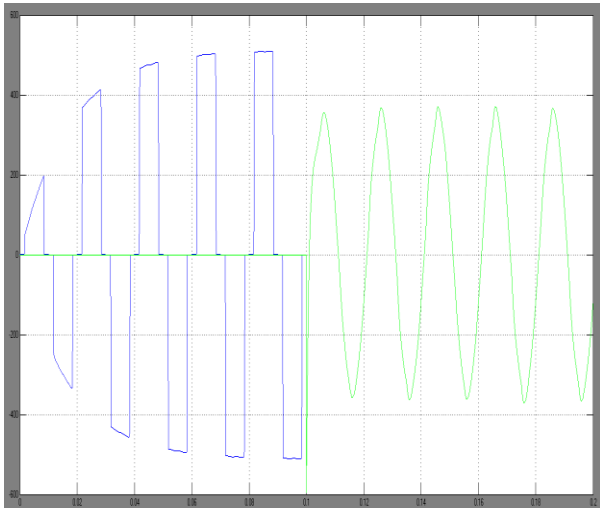

Fig.27 Grid phase and reference currents

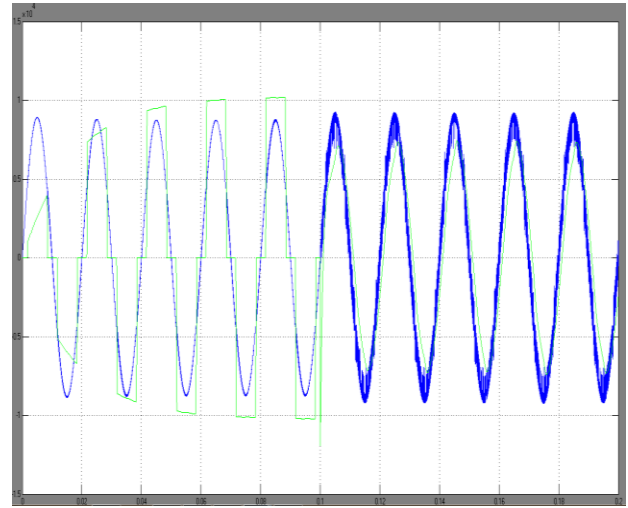

Fig.29 Power factor angle between source voltage and current

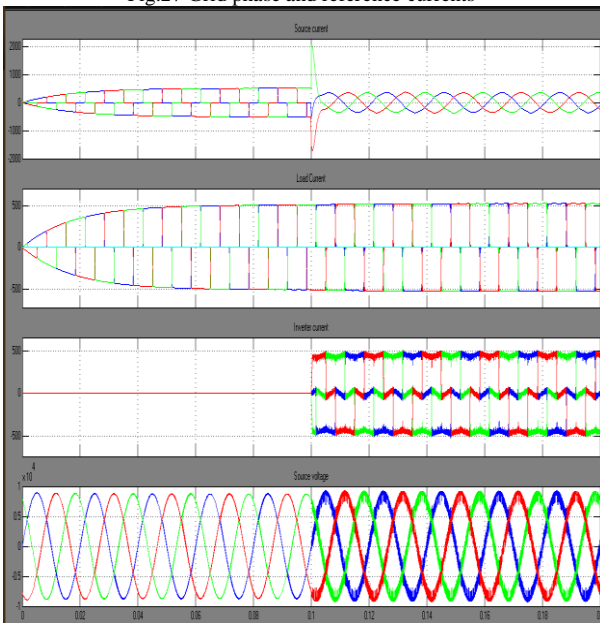

Fig.28 Source current, Load current, D-STATCOM injected harmonic current and Source voltage

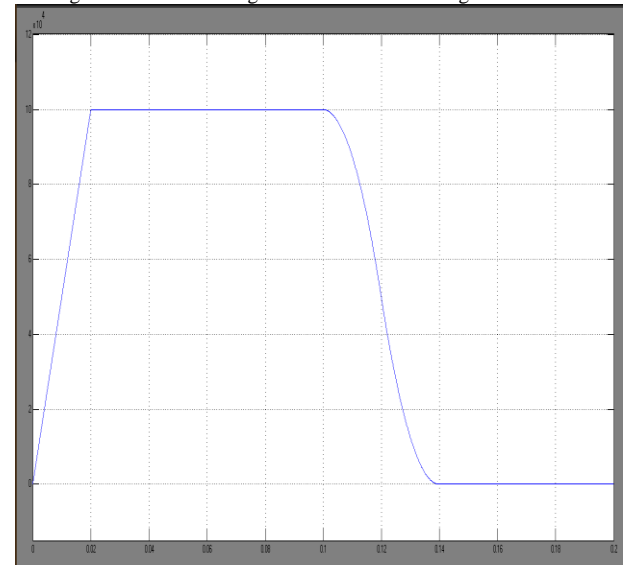

Fig.30 Reactive power generated by Grid

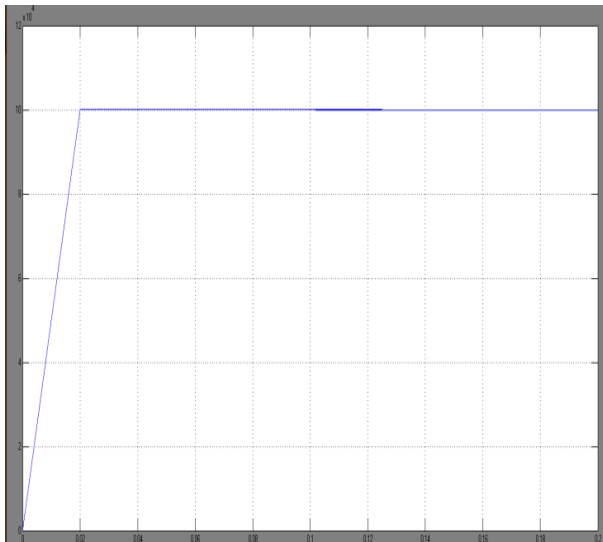

Fig.31 Reactive power generated by Grid

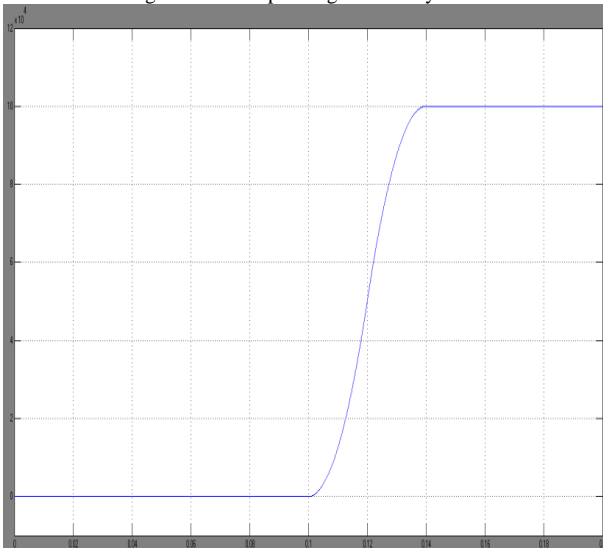

Fig.32 Reactive power supplied by D-STATCOM

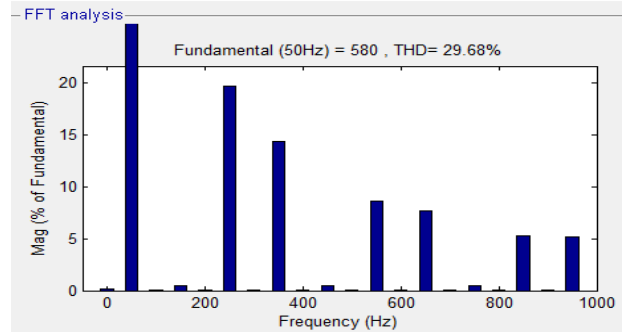
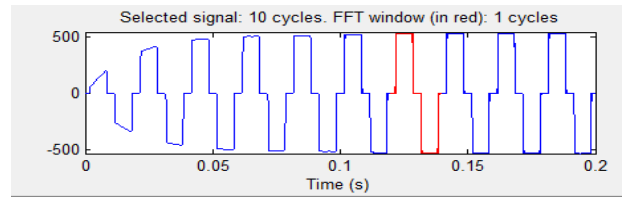

Fig.33 Load current THD

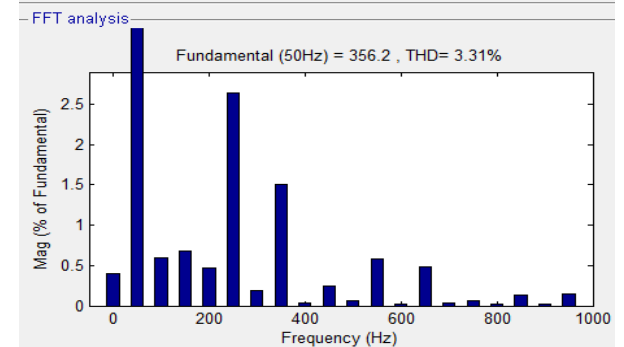
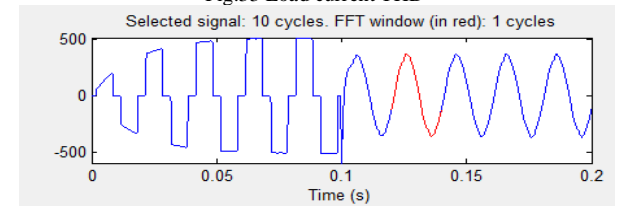

Fig.34 Source current THD

Case: 3 Un-balanced linear loads

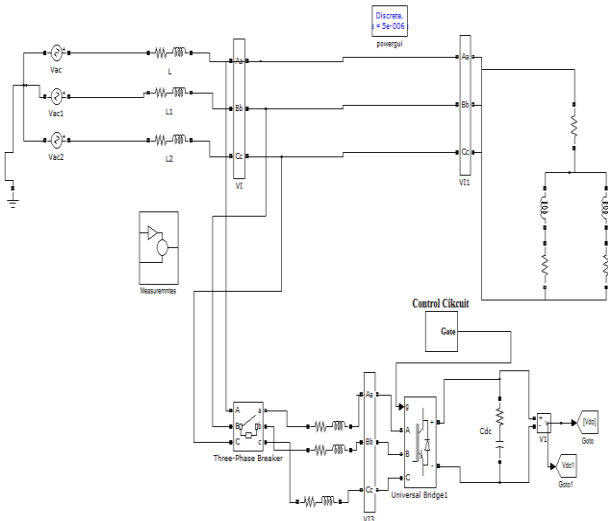

Fig.35 MATLAB/SIMULINK model of D-STATCOM with unbalanced linear loads

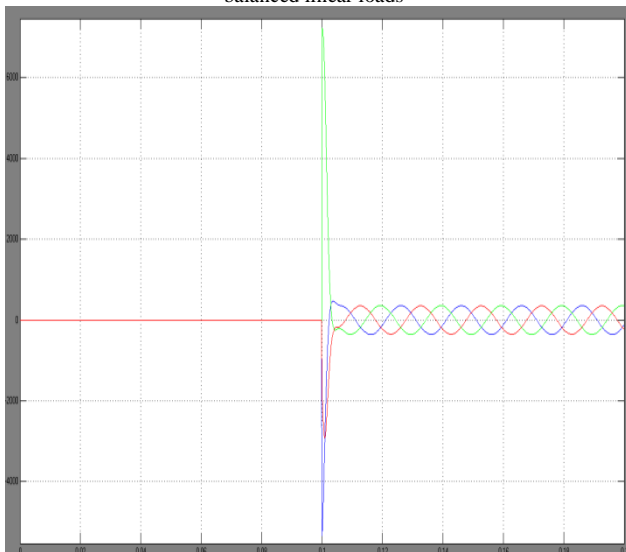

Fig.36 Grid reference current

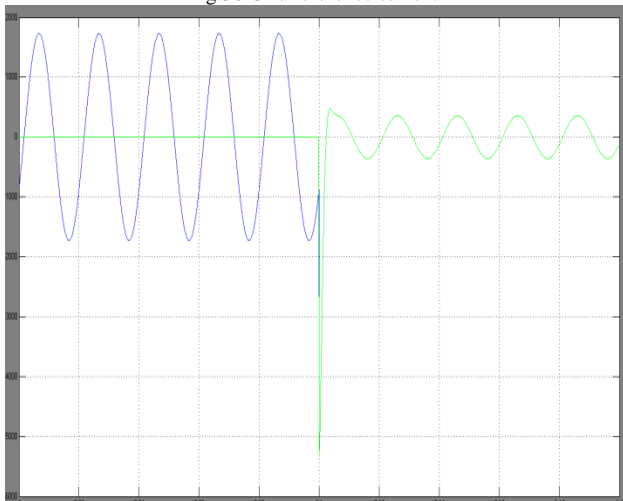

Fig.37 Grid phase and reference currents

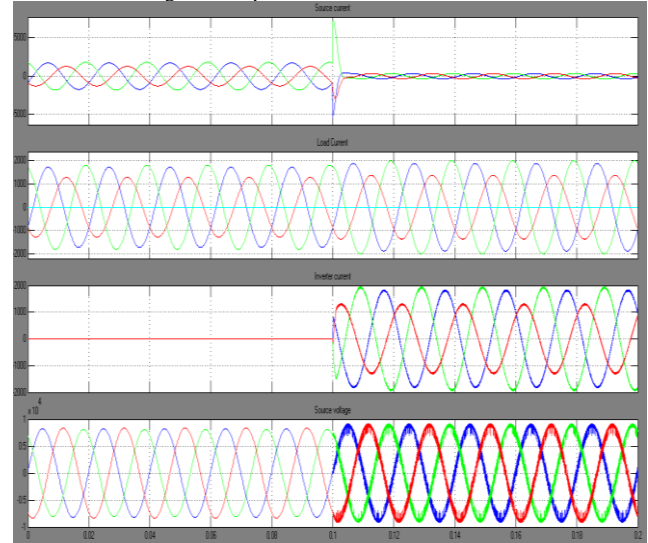

Fig.38 Source current, Load current, D-STATCOM injected harmonic current and Source voltage

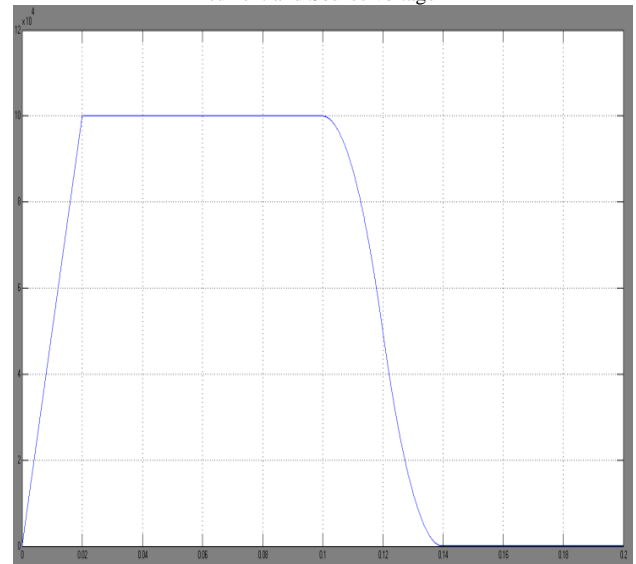

Fig.39 Reactive power generated by Grid

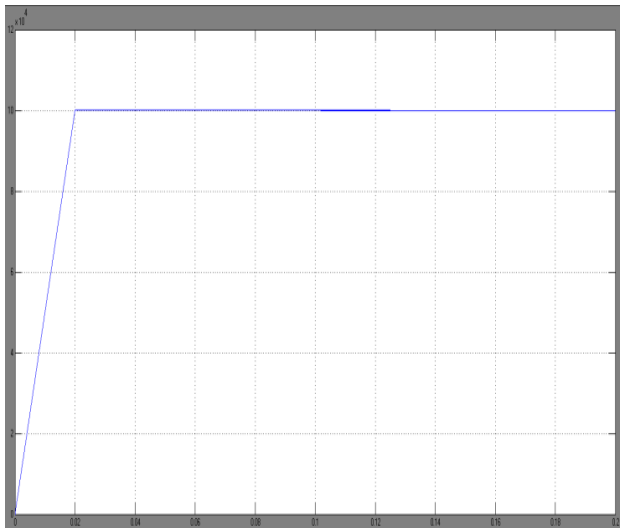

Fig.40 Reactive power demanded by load

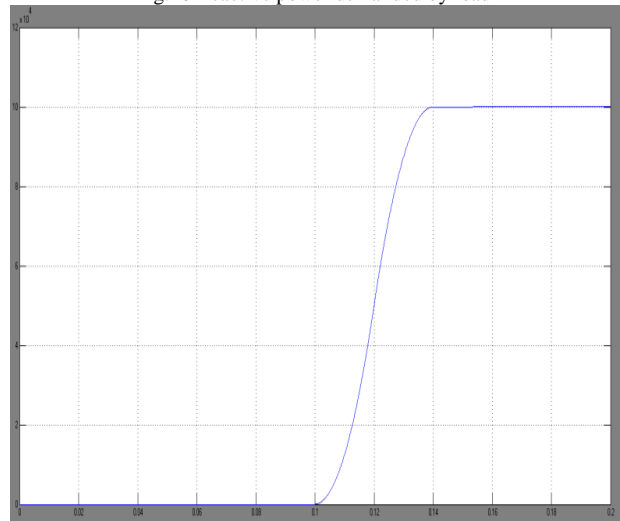

Fig.41 Reactive power supplied by D-STATCOM

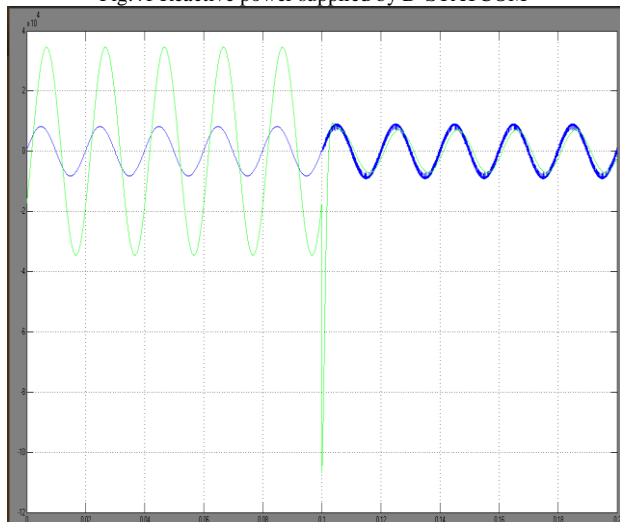

Fig.42 power factor angle between source voltage and current

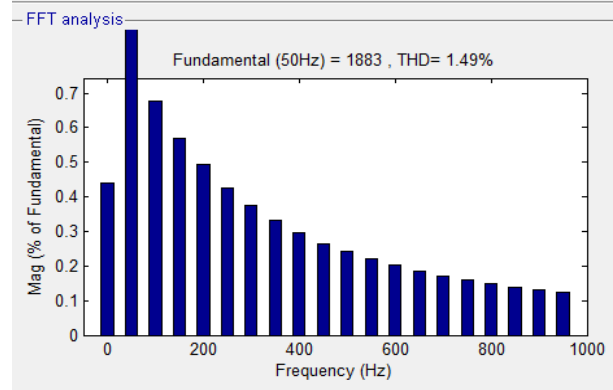
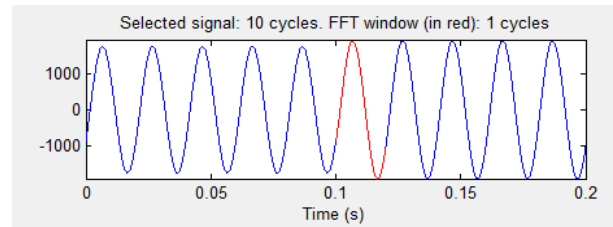

Fig.43 Load current THD

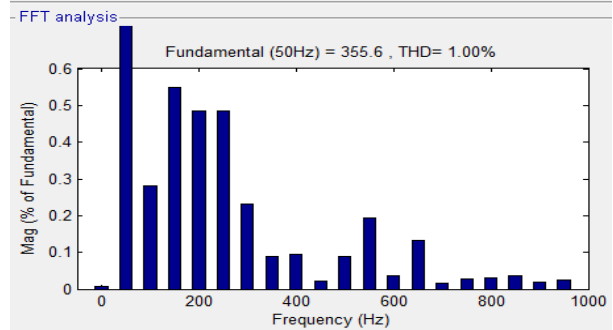
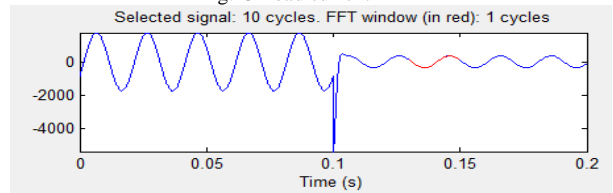

Fig.44 Source current THD

Case: 3 Un-balanced non-linear loads

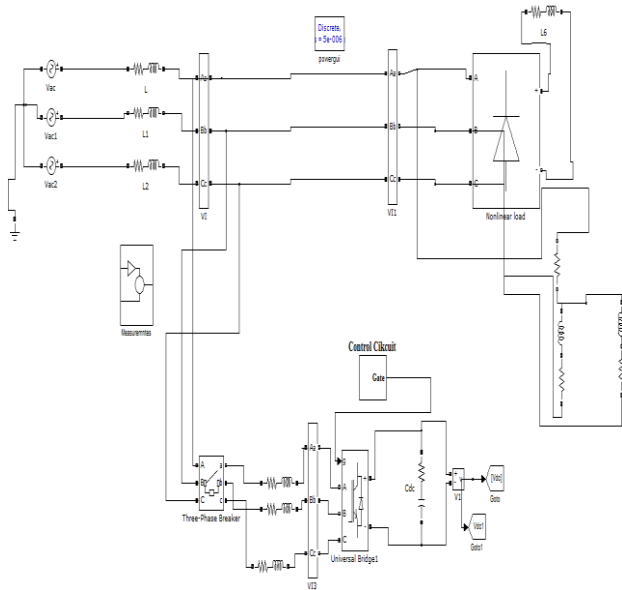

Fig.45 MATLAB/SIMULINK model of D-STATCOM with unbalanced non linear loads

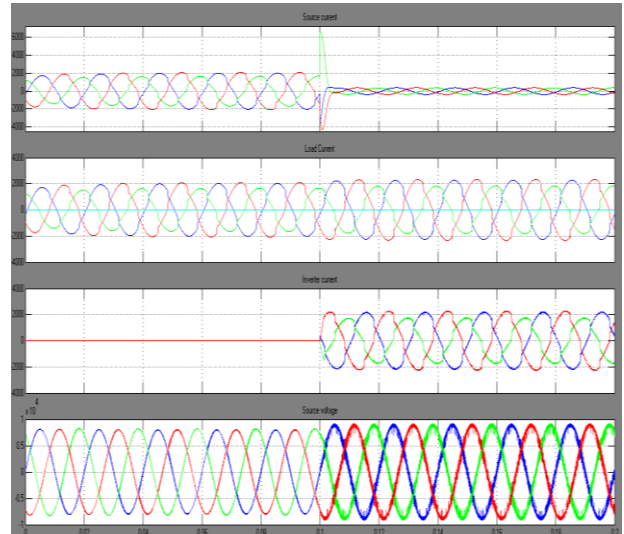

Fig.48 Source current, Load current, D-STATCOM injected harmonic current and Source voltage

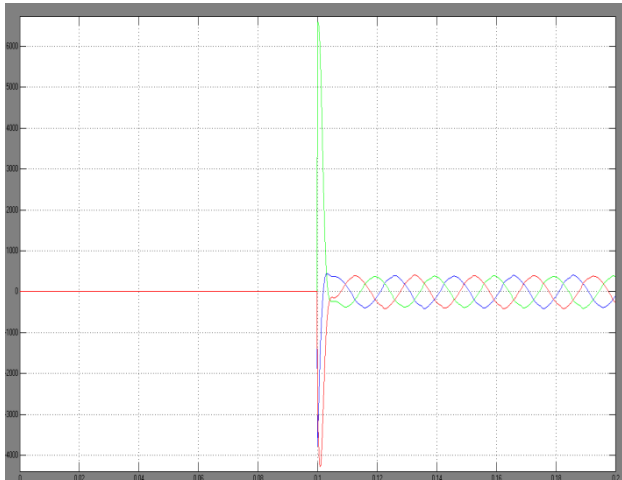

Fig.46 Grid reference current

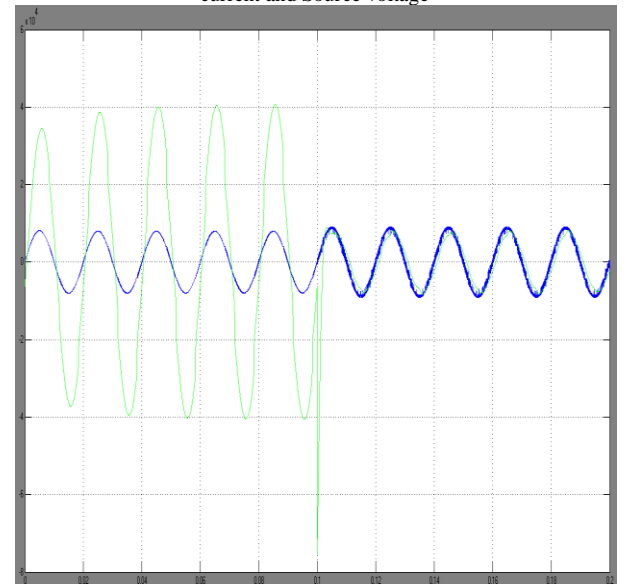

Fig.49 Power factor angle between source voltage and current

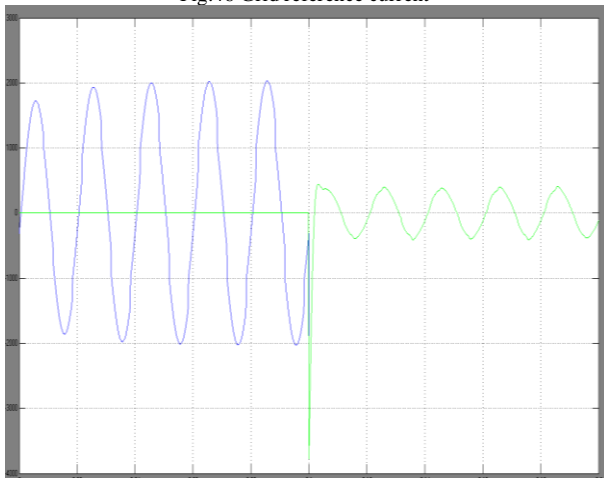

Fig.47 Grid phase and reference currents

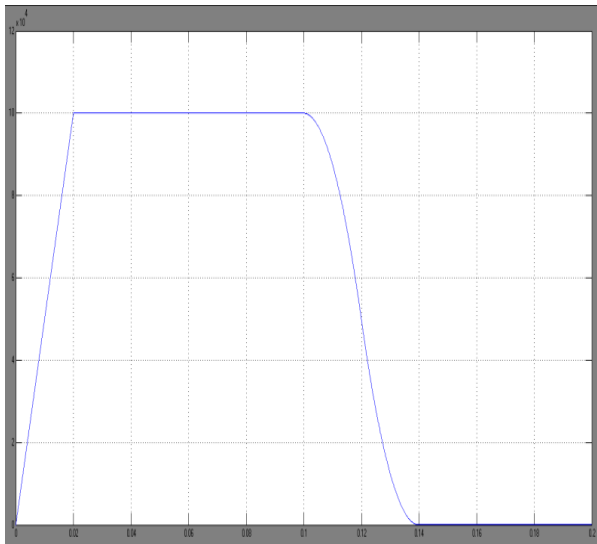

Fig.50 Reactive power generated by Grid

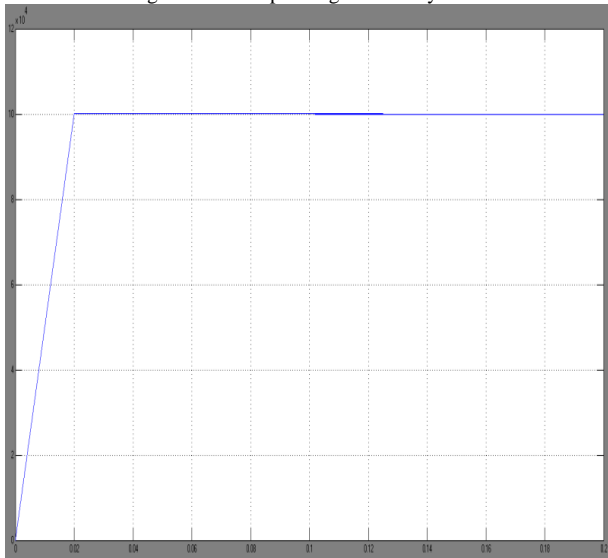

Fig.51 Reactive power demanded by load

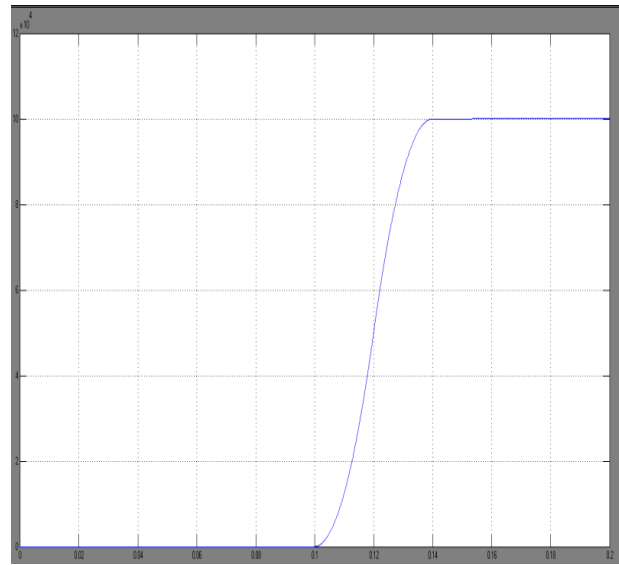

Fig.52 Reactive power supplied by D-STATCOM

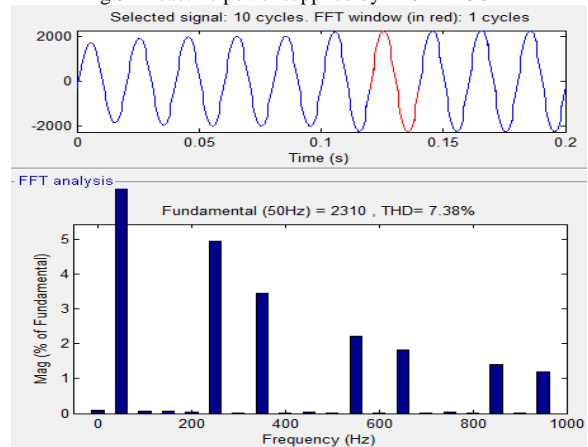

Fig.43 Load current THD

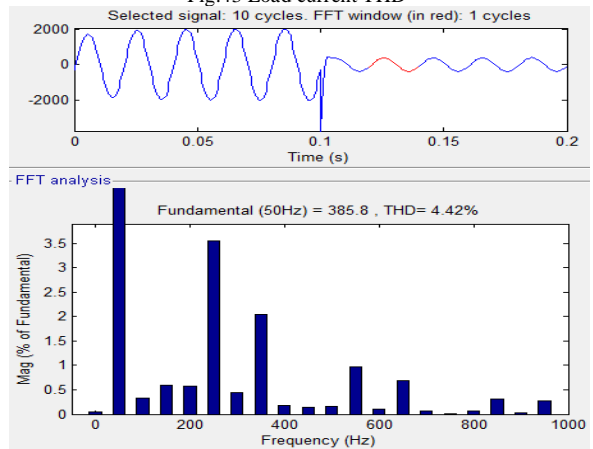

Fig.44 Source current THD

VIII. CONCLUSION

In this work, a fast and cost effective Distribution STATCOM (DSTATCOM) is proposed for mitigating the

problem of harmonic elimination, load balancing and reactive power compensation is done in order to mitigate power quality problems. The simulation results show that the performance of DSTATCOM system has been found to be satisfactory for improving the power quality at the consumer premises. DSTATCOM control algorithm is flexible and it has been observed to be capable of correcting power factor to unity, eliminate harmonics in supply currents and provide load balancing. It is also able to regulate voltage at PCC. The control algorithm of DSTATCOM has an inherent property to provide a self supporting DC bus of DSTATCOM. It has been found that the DSTATCOM system reduces THD in the supply currents for non-linear loads. Rectifier-based non-linear loads generated harmonics are eliminated by DSTATCOM. When single phase non-linear-loads linear loads, DSTATCOM currents balance these unbalanced load currents. Finally Matlab/Simulink based model is developed and simulation results are presented.

REFERENCES

- [1] Dinesh Kumar and Rajesh, "Modeling, Analysis and Performance of a DSTATCOM for Unbalanced and Non-Linear Load", IEEE/PES Conference on Transmission and Distribution conference and Exhibition Asia and Pacific, Publication, pp. 1 – 6, 2005.
- [2] Waldir Freitas, Andre Morelato, Wilsun Xuand Fujio Sato, "Impacts of AC Generators and D-DSTATCOM Devices on the Dynamic Performance of Distribution Systems", IEEE Transactions on Power Delivery, pp. 1493 – 1501, 2005.
- [3] P. M. Meshram, B.Y.Bagde, R.N.Nagpure, "A Novel FACTS Device for the Improvement of Power Quality of the Supply", 2nd International Conference on Electrical Engineering and Electronics, Computer, Telecommunications and Information Technology (ECTI-CON 2005), vol.1, pp. 775-778,2005.
- [4] M. G. Molina, P. E. Mercado, "Control Design and Simulation of D-DSTATCOM with Energy Storage for Power Quality Improvements", IEEE/PES Conference on Transmission and Distribution Conference and Exposition Latin America, Venezuela, pp.1 - 7, 2006.
- [5] Bhim Singh, AlkaAdya, A.P.Mittal and J.R.P. Gupta, "Modelling, Design and Analysis of Different Controllers for D-DSTATCOM", IEEE Power India Conference on Power system technology and, 2008, pp. 1 -8, 2008.
- [6] Meenakshi Rastogi, Abdul Hamid Bhat. "Reactive Power Compensation Using Static Synchronous Compensator (STATCOM) with Conventional Control Connected with 33kv Grid", Proceedings of 2nd international conference of RA ECS, IEEE, pp. 1-5, (2015).

- [7] Vandana S Pal, Joy. "Reactive power compensation and in a lossless transmission line by the application of Statcom", Proceedings of Second IRF International Conference, Cochin, India, and ISBN: 978-93-84209-43-8, (2014).
- [8] Arindam Chakraborty, 1 Shravana K.Musunuri, 2 Anurag K.Srivastava,3 and Anil K. Kondabathini4 "Integrating DSTATCOM and Battery Energy Storage System for Power System Transient Stability: A Review and Application"
- [9] L. Zhang, C. Shen, M. L. Crow, L. Dong, S. Pekarek, and S. Atcity, "Performance indices for the dynamic performance of FACTS and FACTS with energy storage," Electric Power Components and Systems, vol. 33, no. 3, pp. 299–314, 2005.
- [10] S. Srikanthan and M. K. Mishra, "DC capacitor voltage equalization in neutral clamped inverters for DSTATCOM application," IEEE Trans. Ind. Electron., vol. 57, no. 8, pp. 2768–2775, Aug. 2010.
- [11] S. Srikanthan and M. K. Mishra, "An improved hysteresis current control of three level inverter for DSTATCOM application," in Proc.Nat. Power Electron. Conf., IISc Bangalore, India, Dec. 2007, pp1–

AUTHOR DETAILS



K.NAGA RAJU
Assistant Professor
Department of Electrical & Electronics Engineering,
Geethanjali college of engineering and technology, cheeryal;
Medchal (DT); Telangana, India.



B RAMESH BABU
Assistant Professor
Department of Electrical & Electronics Engineering,
Geethanjali college of engineering and technology, cheeryal;
Medchal (DT); Telangana, India.