

Review On FACTS Devices for Power System Stability Enhancement

¹G.Vaddikasulu and ²V.S.Vakula, ³K.B.Madhu Sahu

¹Research Scholar, ²Asst.Professor, ³Professor.

¹Department of Electrical and Electronics Engineering,
JNTU KAKINDA, KAKINADA, India.

¹gvkaec@gmail.com, ²dr.vakulavs.jntu@gmail.com, ³kbmadhusahu@gmail.com

Abstract: Due to increase in population and industrial growth, insufficient energy resources to generate or transmit the power in power system, increase in load causes power demand in the electrical power system. These power demand leads to voltage instability, increase the losses, reduces the power transfer capability and stability of the power system. To overcome this stability problem FACTS devices are optimally located in the power system to examine the stability of the system. To locate the FACTS devices different optimization algorithms are used in order to improve the stability of the electrical power system.

Keywords: Facts Devices, Optimization Algorithms, Power System Stability

I. INTRODUCTION

The power system becomes unstable due to increase in power transfer it becomes more difficult to operate and becomes insecure because of increase of power losses in the power system. Optimization is a technique which is used to optimally allocate the FACTS devices like Static Var Compensator (SVC) and Inter Line Power Flow Controller (IPFC) in power system to minimize the power losses, improve the Power transfer capability and voltage profile of the system Particle Swarm Optimization (PSO) algorithm [1]. IPFC were located in the transmission line to minimize the transmission line losses by using the Genetic Algorithm (GA) which also controls the power transfer in the power system by series connection of IPFC [2]. Anti Bee Colony (ABC) algorithm were used to locate the IPFC in the transmission line for optimally locating with poorer cost [3]. Unified Power Flow Controllers (UPFC) was used to improve the voltage stability in the transmission line. GA is an algorithm to optimally locate the UPFC which is used to control the

voltage stability and angle of sending and receiving end bus [4]. Optimal allocation of multiple facts device under different overload conditions to improve the power transfer capability and voltage profile of the system by PSO algorithm [5]. SVC and IPFC were optimally allocated under normal, different over load and contingency conditions using PSO technique

[6]. UPFC were optimally located in the power system to improve the voltage profile and as well as reduce the losses by Gravitational Search Algorithm (GSA) [7]. Locating the

SVC by GA in order to improve the stability of the power system with lower cost [8]. To find the optimal location of Thyristor Controlled Series Compensator (TCSC) by an optimization technique GA for analyzes the load ability and total losses of the transmission line which enhance the stability of the power system [9].

II. CLASSIFICATION OF FACTS DEVICES

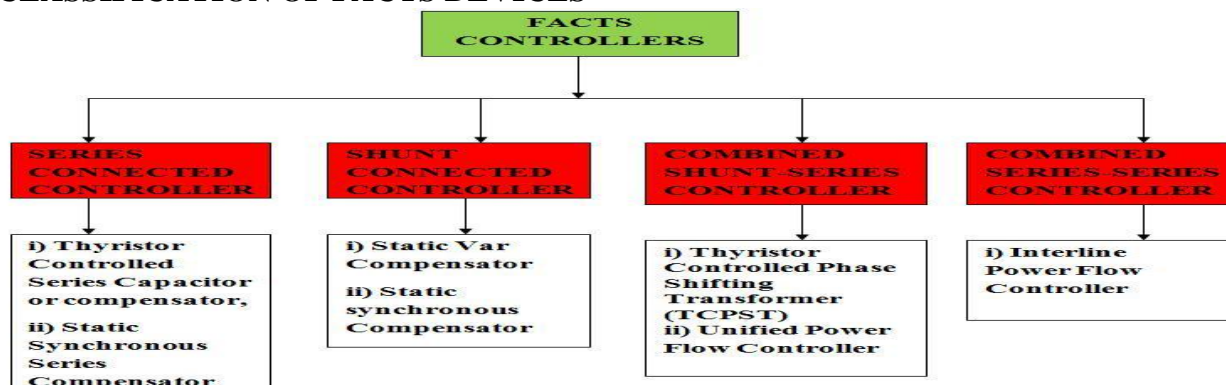

Figure 1: Classification of Facts Devices The Facts controllers can be classified as

1. Shunt connected controllers
2. Series connected controllers
3. Combined series-series controllers
4. Combined shunt-series controllers
- iii. Interline Power Flow Controller (IPFC) (combined series-series)
- iv. Unified Power Flow Controller (UPFC) (combined shunt-series)

Depending on the power electronic devices used in the control, the FACTS controllers can be classified as

- (A) Variable impedance type
- (B) Voltage Source Converter (VSC) based.

A. The variable impedance type controllers

- i. Static Var Compensator (SVC), (shunt connected)
- ii. Thyristor Controlled Series Capacitor or compensator (TCSC), (series connected)
- iii. Thyristor Controlled Phase Shifting Transformer (TCPST) or Static PST (combined shunt and series)

B. The VSC based FACTS controllers

- i. Static synchronous Compensator (STATCOM) (shunt connected)
- ii. Static Synchronous Series Compensator (SSSC) (series connected)

III. STATIC VAR COMPENSATOR

The Static Var Compensator (SVC), a first generation FACTS controller. It is a variable impedance device where the current through a reactor is controlled using back to back connected thyristor valves. The objective is to provide dynamic power factor improvement and also balance the currents on the source side whenever required. The objectives of SVC are

1. Increase power transfer in long lines
2. Improve stability with fast acting voltage regulation
3. Damp low frequency oscillations due to swing (rotor) modes
4. Damp sub synchronous frequency oscillations due to tensional modes
5. Control dynamic over voltages

A SVC has no inertia compared to synchronous condensers and can be extremely fast in response (2-3 cycles). This enables the fast control of reactive power in the control range.

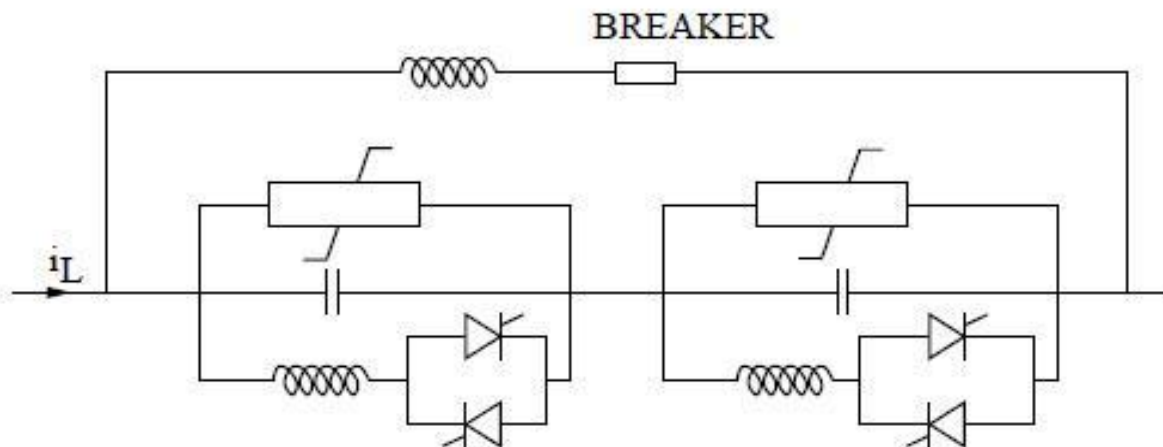

Figure 2: A Typical SVC (TSC-TCR) Configuration

This shows that the TCR and TSC are connected on the secondary side of a step-down transformer. Tuned and high pass filters are also connected in parallel which provide capacitive reactive power at fundamental frequency. The voltage signal is taken from the high

voltage SVC bus using a potential transformer. The TSC is switched in using two thyristor switches (connected back to back) at the instant in a cycle when the voltage across valve is minimum and positive. This results in minimum switching transients. In steady state, TSC does

not generate any harmonics. To switch off a TSC, the gate pulses are blocked and the thyristors turn off when the current through them falls below the holding currents. It is to be noted that several pairs of thyristors are connected in series as the voltage rating of a thyristor is not adequate for the voltage level required. However the

voltage ratings of valves for a SVC are much less than the voltage ratings of a HVDC valve as a step down transformer is used in the case of SVC. To limit di/dt in a TSC it is necessary to provide a small reactor in series with the capacitor.

IV. CONFIGURATION OF

SVC There are two types of SVC:

1. Fixed Capacitor-Thyristor Controlled Reactor (FC-TCR)
2. Thyristor Switched Capacitor

Thyristor Controlled Reactor (TSC-TCR). The second type is more flexible than the first one and requires smaller rating of the reactor and consequently generates fewer harmonics. The schematic diagram of a TSC-TCR type SVC is shown in Fig. 2

V. THYRISTOR CONTROLLED SERIES CAPACITOR

A single line diagram of a TCSC is shown in Fig. 3 which shows two modules connected in series. There can be one or more modules depending on the requirement. To reduce the costs, TCSC may be used in conjunction with fixed series capacitors.

A. Bypassed

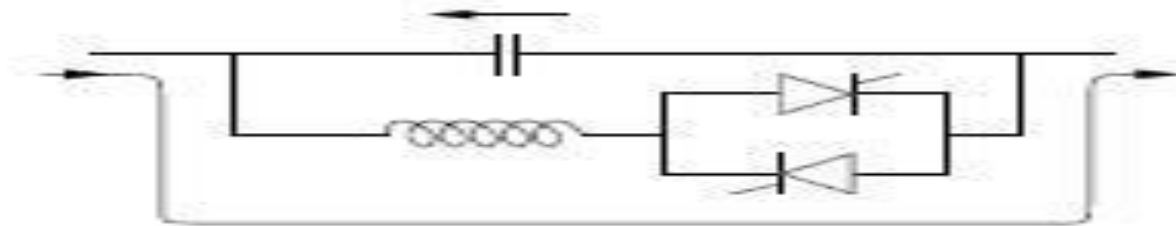

Figure 4: Bypassed mode

During this mode, most of the line current is flowing through the reactor and thyristor valves with some current flowing through the capacitor. This mode is used mainly for protecting the capacitor against over voltages (during transient over currents in the line). This mode is also termed as TSR (Thyristor Switched Reactor) mode.

B. Inserted with Thyristor Valve Blocked

Figure 3: Single line diagram of TCSC

Fig 4: shows bypassed mode of TCSC. Here the thyristor valves are gated for 180° conduction (in each direction) and the current flow in the reactor is continuous and sinusoidal. The net reactance of the module is slightly inductive as the susceptance of the reactor is larger than that of the capacitor.

Fig 5: shows the thyristor blocked mode of TCSC. In this operating mode no current flows through the valves with the blocking of gate pulses. Here, the TCSC reactance is same as that of the fixed capacitor and there is no difference in the performance of TCSC in this mode with that of a fixed capacitor. Hence this operating mode is generally avoided. This mode is also termed as waiting mode.

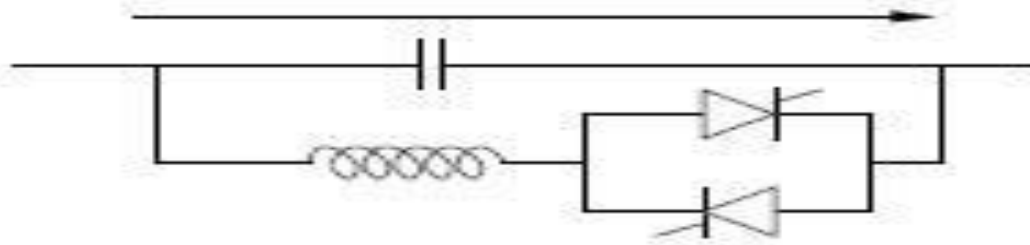

the part of a cycle. The effective value of TCSC reactance (in the capacitive region) increases as the conduction angle increases from zero. α_{min} is above the value of α corresponding to the parallel resonance of TCR and the capacitor (at fundamental frequency). In the inductive vernier mode, the TCSC (inductive) reactance increases as the conduction angle reduced from 180 degree.

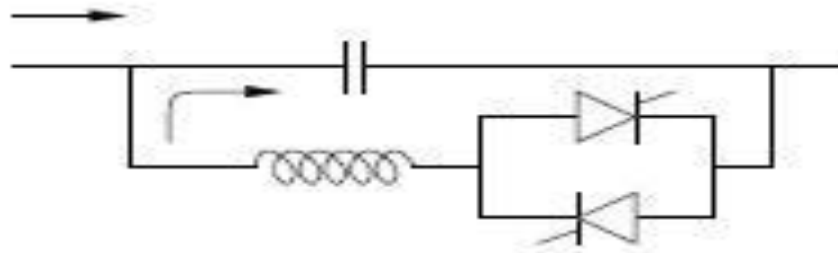

Figure 6: Vernier control mode

Generally, vernier control is used only in the capacitive region and not in the inductive region.

VI. STATIC SYNCHRONOUS COMPENSATOR

This shunt connected static compensator was developed as an advanced static VAR compensator where a voltage source converter (VSC) is used instead of the controllable reactors and switched capacitors. Although VSCs require self-commutated power semiconductor devices such as GTO, IGBT, IGCT, MCT, etc (with higher costs and losses) unlike in the case of variable impedance type SVC which use thyristor devices, there are many technical advantages of a STATCOM over a SVC.

1. Faster response

Figure 5: Thyristor blocked mode

C. Inserted with Vernier Control

Fig 6: shows the vernier control mode of TCSC. In this operating mode, the thyristor valves are gated in the region of $\alpha_{min} < \alpha < 90$ degree. Such that they conduct for

2. Requires less space as bulky passive components (such as reactors) are eliminated
3. It can be interfaced with real power sources such as battery, fuel cell or SMES (superconducting magnetic energy storage)
4. A Statcom has superior performance during low voltage condition

as the reactive current can be maintained constant (In a SVC, the capacitive reactive current drops linearly with the voltage at the limit (of capacitive susceptance). It is even possible to increase the reactive current in a STATCOM under transient conditions if the devices are rated for the transient overload. In a SVC, the maximum reactive current is determined by the rating of the passive components – reactors and capacitors.

VII. STATIC SYNCHRONOUS SERIES COMPENSATOR

Fig 7: shows Static Synchronous Series Compensator. The Static Synchronous Series Compensator (SSSC) is a series connected FACTS controller based on VSC and can be viewed as an advanced type of controlled

series compensation, just as a STATCOM is an advanced SVC. A SSSC has several advantages over a TCSC such as

1. Elimination of bulky passive components capacitors and reactors
2. Improved technical characteristics
3. Symmetric capability in both inductive and capacitive operating modes
4. Possibility of connecting an energy source on the DC side to exchange real power with the AC network.

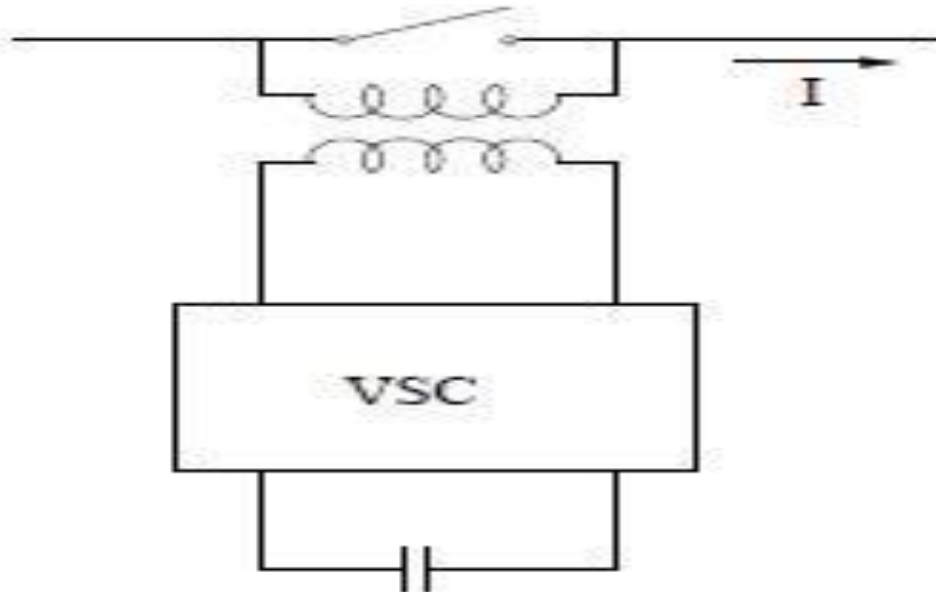
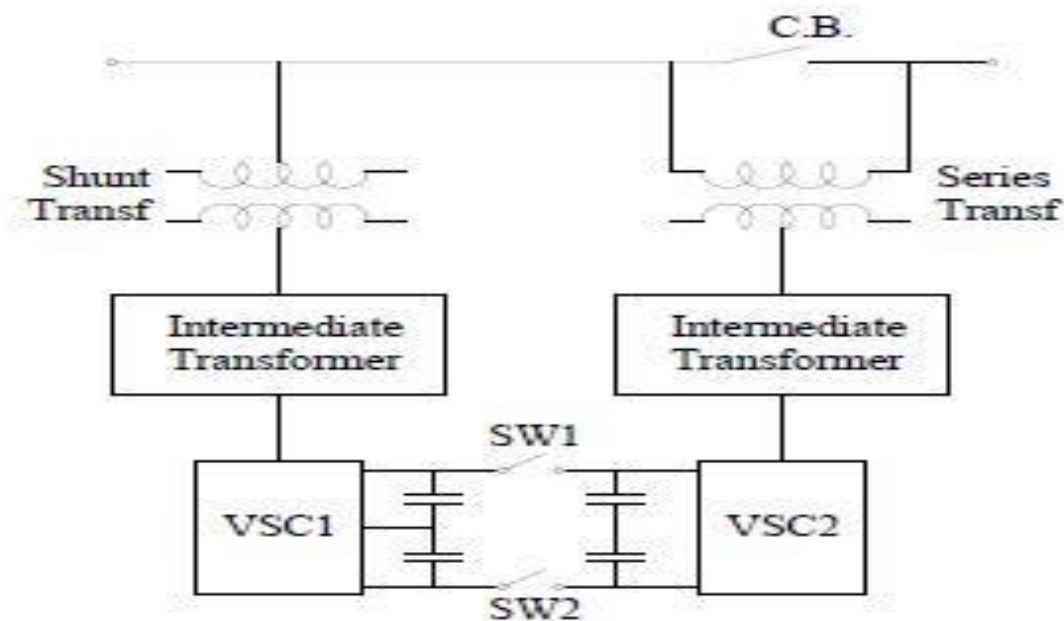

Figure 7: Static Synchronous Series Compensator

VIII. UNIFIED POWER FLOW CONTROLLER



Parallel. If the switches 1 and 2 are open, the two converters work as STATCOM and SSSC controlling the reactive current and reactive voltage injected in shunt and series respectively in the line. The closing of the switches 1 and 2 enable the two converters to exchange real (active) power flow between the two converters. The active power can be either absorbed or supplied by the series connected converter.

The provision of a controllable power source on the DC side of the series connected converter, results in the control of both real and reactive power flow in the line. The shunt connected converter not only provides the necessary power required, but also the reactive current injected at the converter bus. Thus, a UPFC has 3 degrees of freedom unlike other FACTS controllers which have only one degree of freedom.

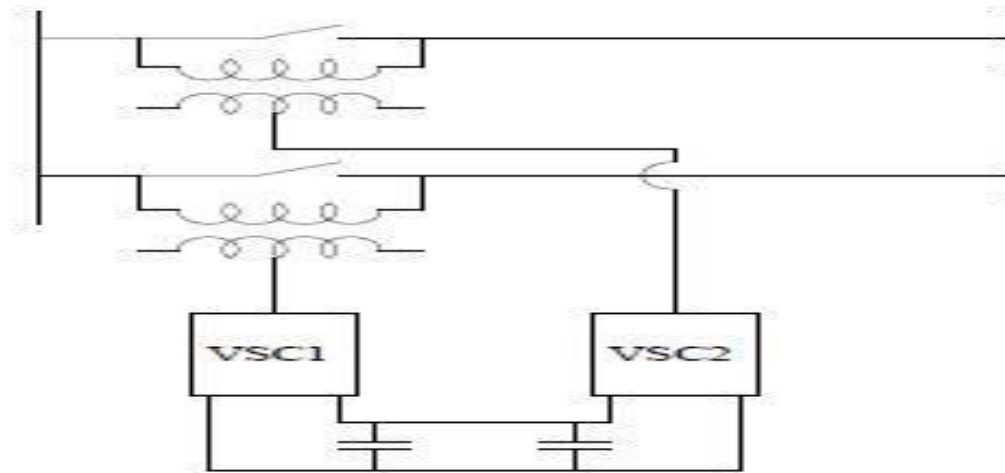

Figure 8: Unified Power Flow Controller

Fig 8: shows Unified Power Flow Controller. The Unified Power Flow Controller (UPFC) proposed by Gyugyi is the most versatile FACTS controller for the regulation of voltage and power flow in a transmission line. It consists of two voltage source converters (VSC) one shunt connected and the other series connected. The DC capacitors of the two converters are connected in

Fig 8: Inter Line Power Flow Controller

Fig 8: shows Inter Line Power Flow Controller. The IPFC provides, in addition to the facility for independently controllable reactive (series) compensation of each individual line, a capability to directly transfer or exchange real power. This is achieved by coupling the

series connected VSCs in individual lines on the DC side, by connecting all the DC capacitors of individual converters in parallel. Since all the series converters are

IX. INTERLINE POWER FLOW CONTROLLER

Interline Power Flow Controller. The objective of introducing this controller is to address the problem of compensating a number of transmission lines connected at a substation. While pure series reactive (controllable) compensation (in the form of a TCSC or SSSC) can be used to control or regulate the active power flow in a line, the control of reactive power is not feasible unless active (real) voltage in phase with the line current is not injected. The application of a TCSC (or SSSC with impedance emulation) results in the reduction of net series reactance of the line. However, X/R ratio is reduced significantly and thereby increases the reactive power flow (injected at the receiving end) and losses in the line.

located inside the substation in close proximity, this is feasible.

An IPFC with two converters compensating two lines is similar to a UPFC in that the magnitude and phase angle of the injected voltage in the prime system (or line) can be controlled by exchanging real power with the support system. The basic difference with a UPFC is that the support system in the latter case is the shunt converter instead of a series converter. The series converter associated with the prime system (of one IPFC) is termed as the master converter while the series converter associated with the support system is termed as the slave converter. The master converter controls both active and reactive voltage (within limits) while the slave converter controls the DC voltage (across the capacitor) and the reactive voltage magnitude.

CONCLUSION

Manu K., Kusumadevi G. H., “Optimal Location of Multi Type FACTS Device for Single Contingency Using Genetic Algorithm” The International Journal Of Science & Technoledge Vol 2 Issue 7 July, 2014 Dr. E. NandaKumar, R.MANI “Optimal Location of UPFC in Power System Using Gravitational Search Algorithm” International Journal of Innovative Research in Technology & Science (IJIRTS) Mohd Wazir Mustafa, Wong Yan Chiew “Optimal Placement of

In this paper shows about the different FACTS devices which are used to increase the voltage profile,

Static VAR Compensator Using Genetic Algorithms”ELEKTRIKA VOL. 10, NO. 1, 2008, 26-31 Jaswinder , Sunny Vig Singh “Power Quality improvement of Wind Power using Facts Device”International Journal of Engineering Research & Technology (IJERT) Vol. 4 Issue 05, May-2015

reduces the line losses, increase the power transfer capability of the system. From this the STATCOM and IPFC has the capability to improve the stability of the system with minimum cost and size.

References

- [1] M .V. Ramesh, V.C. Veera Reddy “Optimal Placement Of Facts Devices In An Electrical System”, International Journal Of Advances In Science Engineering And Technology,, Vol- 1, Issue- 2, Oct-2013
- [2] Akanksha Mishra and G.V. Nagesh Kumar, “Congestion Management of Power System with Interline Power Flow Controller Using Disparity Line Utilization Factor and Multi-objective Differential Evolution” CSEE Journal of Power and Energy Systems, Vol. 1, No. 3, September 2015
- [3] S. Sreejith, Sishaj Psimon, M.P. Selvan “Optimal location of interline power flow controller in a power system network using ABC algorithm” Archives Of Electrical Engineering Vol. 62(1), Pp. 91-110 (2013)
- [4] Priyank Srivastava, Rashmi Pardhi “A Review on Power System Stability and Applications of FACT Devices” International Journal of Engineering Research and Applications (IJERA)
- [5] E. Nanda Kumar, R. Dhanasekaran and R. Mani “Optimal Location and Improvement of Voltage Stability by UPFC using Genetic Algorithm (GA)” Indian Journal of Science and Technology, Vol 8(11)
- [6] M.V.Ramesh, M.Tech Dr. V.C. Veera Reddy “Optimal Allocation Of Facts Devices In Different Over Load Conditions” International Journal Of Electrical Engineering & Technology, Vol 8(11),