

Analysis Of Different Topologies For Active Power Factor Correction In Dc – Dc Converters

Kallepu Laxmi Bhavani & Dr.M.Ramesh

1.Pg Scholar, Department of EEE, Vaageswari College of Engineering, karimnagar.

2. Professor&Hod, Department Of EEE, Vaageswari College Of Engineering, Karimnagar.

ABSTRACT

A systematic method for developing isolated buckboost (IBB) converters is proposed in this paper, and single-stage power conversion, soft-switching operation, and high-efficiency performance can be achieved with the proposed family of converters. On the basis of a nonisolated two-switch buck-boost converter, the proposed IBB converters are generated by replacing the dc buck-cell and boost-cell in the non-IBB converter with the ac buck-cell and boost-cell, respectively. Furthermore, a family of semiactive rectifiers (SARs) is proposed to serve as the secondary rectification circuit for the IBB converters, which helps to extend the converter voltage gain and reduce the voltage stresses on the devices in the rectification circuit. Hence, the efficiency is improved by employing a transformer with a smaller turns ratio and reduced parasitic parameters, by using low-voltage rating MOSFETs and diodes with better switching and conduction performances. A fullbridge IBB converter is proposed and analyzed in detail as an example. The phase-

shift modulation strategy is applied to the full-bridge IBB converter to achieve IBB conversion. Moreover, soft-switching performance of all active switches and diodes can be achieved over a wide load and voltage range by the proposed converter and control strategy. A 380-V-output prototype is fabricated to verify the effectiveness of the proposed family of IBB converters, the SARs, and the control strategies.

I INTRODUCTION

In this chapter, we derive the dynamic models of DC-to-DC power converters. The most elementary structures of these converters are broadly classified into *second order converters* and *fourth order converters*. In addition to the number of independent switches they are classed into two groups: *mono-variable*, or *Single Input Single Output (SISO)*, and *multi-variable*, or *Multiple Input Multiple Outputs (MIMO)*. The most commonly used converters correspond to the SISO second order converters. The advantages and difficulties of the MIMO converters is just beginning to be fully understood. We remark that

there are converters with *multiple dependent* switches. These may still be SISO or MIMO. The second order converters that we study in this book are: the Buck converter, the Boost converter, the Buck-Boost converter and the non-inverting Buck-Boost converter. The fourth order converters are: the Cuk converter, the Sepic converter, the Zeta converter and the quadratic Buck converter. Some multi-variable converters can be obtained by a simple cascade arrangement of the basic SISO converter topologies while considering the switch in each stage as being completely independent of the other switches present in the arrangement. Many books in the Power Electronics literature present derivations of the power converters models. For a rather thorough presentation of the Euler-Lagrange modelling technique in DC-to-DC power converters, the reader is referred to the book by Ortega *et al.*. The authors find the pioneering book by Severns and Bloom quite accessible and direct. The thoughtful book by Kassakian *et al.* contains also detailed derivations of the most popular DC-to-DC power converters topologies. Standard reference textbooks, which do contain models of DC-to-DC power converters but with a special emphasis on the steady state PWM switched

We extensively use, in the derivation of the dynamic controlled models of the several

converters, the fundamental Kircho's current and Kircho's

2 Modelling of DC-to-DC Power Converters

voltage laws. The methodology for the derivation of the models is, therefore, quite straightforward. We fix the position of the switch, or switches, and derive the differential equations of the circuit model. We then combine the derived models into a single one parameterized by the switch position function whose value must coincide, for each possible case, with the numerical values of either "0" or "1". In other words, the numerical values ascribed to the switch position function is the binary set $\{0, 1\}$. The obtained switched model is then interpreted as an *average model* by letting the switch position function take values on the closed interval of the real line $[0, 1]$. This state averaging procedure has been extensively justified in the literature since the early days of power electronics and, therefore, we do not dwell into the theoretical justifications of such averaging procedure. The consequences of this idealization will

not be counterproductive in the controller design procedure, nor in its actual implementation through Pulse Width Modulated (PWM) "electronic actuators" or its corresponding sliding mode counterparts. In order to simplify the exposition, we make no distinction between the average model variables and the switched model

variables. At the beginning, we shall only distinguish between these models by using u_{av} for the control input variable in the average model and by using u for the switched model. In later chapters, we shall also lift this distinction. It will be clear from the context whether we are referring to the average or to the switched model.

3 The Buck Converter 13

variables. Naturally, as long as actual laboratory implementation goes, the normalization considerably simplifies the controller design but the obtain design cannot be directly implemented. The actual gain values and expressions in the derived controllers have to be naturally "de-normalized" (i.e., placed in original physical units) before the implementation. We believe such an extra effort is worth the pain. In the exposition about each converter, average models are utilized in establishing the average values of the equilibrium points. We usually parameterize the derived equilibrium points in terms of the desired average normalized value of the output voltage. Other parameterizations are still possible and, in fact, the normalized model equations allow us to carry them out with relative ease. The nature of the parametrization of the equilibrium points usually determines the fundamental characteristic of the converter in the sense

that its static features define the amplifying, attenuating, or even both, features present in a specific converter. We refer to the static average normalized input-output relation as the *static transfer function*. This quantity is readily obtained from the average input value parametrization of the desired equilibrium output voltage.

IV INVERTING BUCK-BOOST CONVERTER TOPOLOGY

A buck converter decreases an input voltage. At least one switch at the input is required to connect the input voltage to one side of the inductor. Another switch at the same side of the inductor switches to ground in the off state or alternatively, a diode takes over the decreasing inductor current. The other side of the inductor is permanently connected to the output. A capacitor has to be in place at the input and at the output for stability reasons and to limit huge voltage drops upon fast load transients. A boost converter increases an input voltage. At least one switch at the output is required to connect one side of the inductor to ground. Another switch at the same side of the inductor switches to the output in the off state or alternatively, a diode takes over the decreasing inductor current. The other side of the inductor is permanently connected to the input. A buck-boost converter basically is a combination of a buck and a boost converter. There are normally two

switches at the input and two switches at the output. It can either increase or decrease the input voltage. An inverting buck-boost converter has only one switch at the input and one switch or a diode at the output. But, to be honest, since integrated circuits usually cannot handle negative voltages, the switch at the output cannot be used. The diode becomes a necessity. Therefore, sometimes a slightly modified boost converter is used and another inductor and another capacitor are arranged as shown in fig. 1 to generate a negative output voltage. Figure.1. Simple buck-boost converter topology The inverter discussed in this paper does not require two inductors but uses the simple one inductor concept shown in fig. 1. Diode D1 just indicates that there is a parasitic pn-junction associated with the PMOS switch S1 which is the only component in figure that is on chip. The rest are all external components. D2 is expected to be a schottky diode. Rout represents the load which could be replaced by a current source Iload. S1 has to be controlled such that the desired voltage VOUT remains stable under all VIN and Iload conditions. In continuous current mode CCM operation the inductor current never reaches zero or goes below zero. S1 is turned on and off with a constant frequency

V.SIMULATION RESULTS:

Fig : Model File:

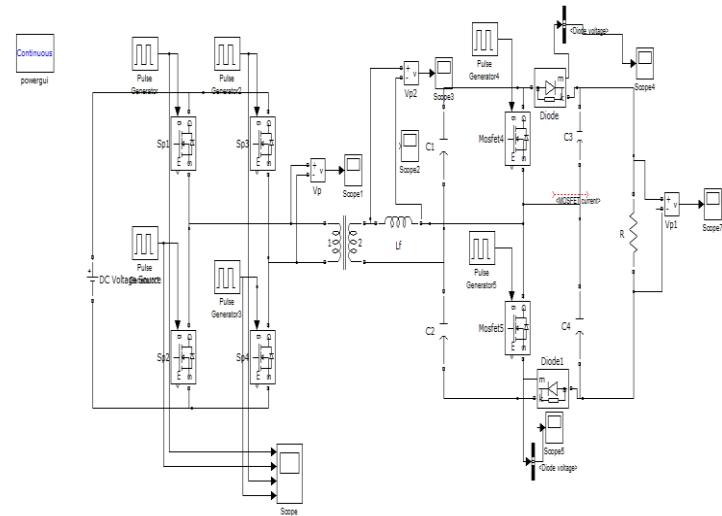
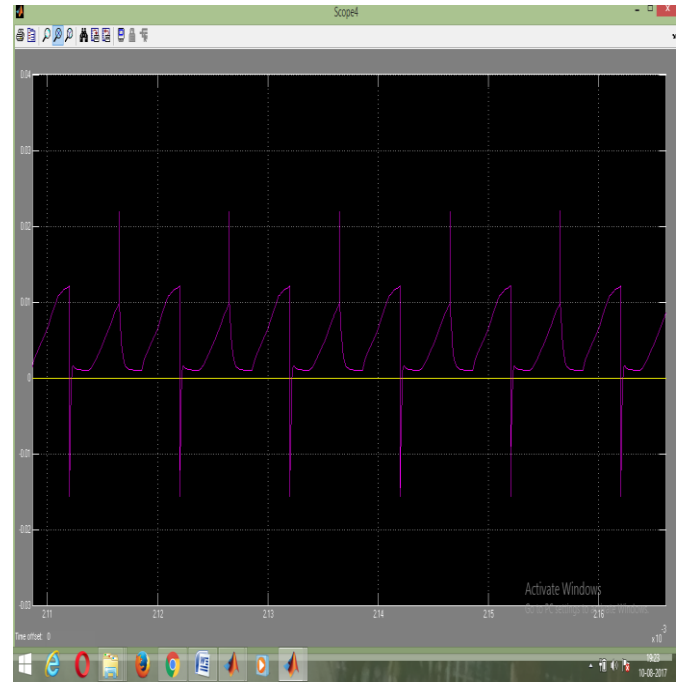
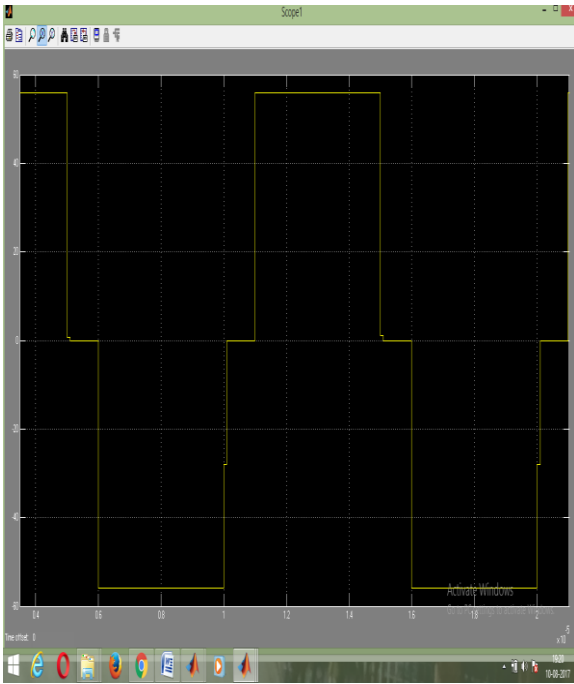
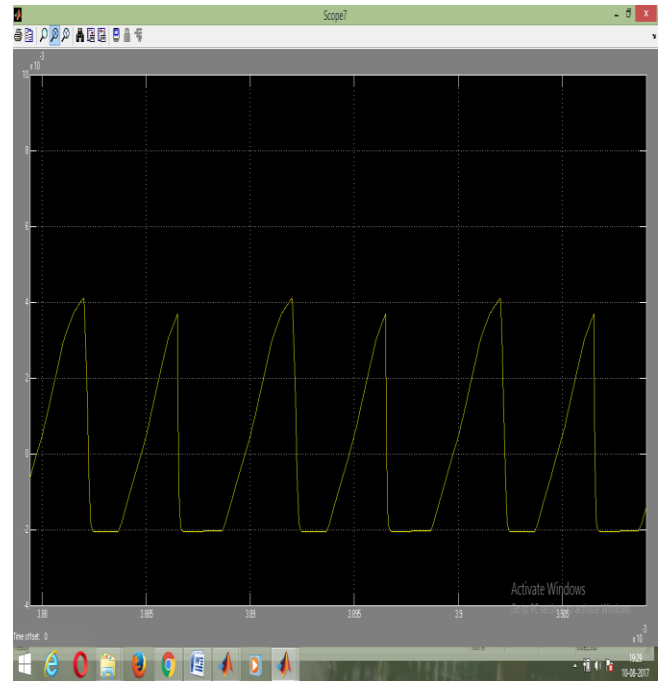
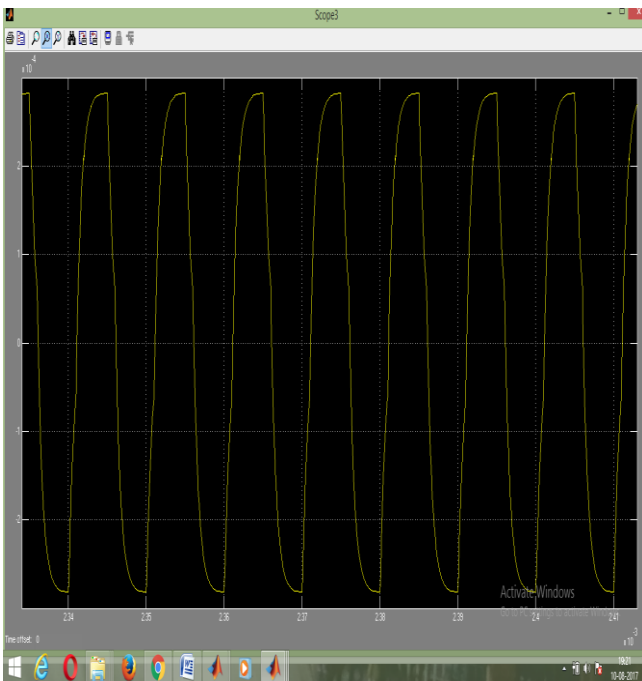

Fig: Simulation Wave forms





V_{if}



The Figs. show the experimental waveforms of the proposed converter in the boost mode. The waveforms in above fig are tested under 40-V input voltage with the normalized voltage gain G

> 1. The waveforms in Fig. 22 are tested under 48-V input voltage with the normalized voltage gain $G = 1$. It can be seen that, when the input voltage is 48 V and the voltage gain $G = 1$, the inductor current i_{Lf} remains constant during the power-transferring state, because the voltage applied to the inductor is nearly zero. When $V_{in} = 40$ V and $G > 1$, the inductor current i_{Lf} decreases during the power-transferring state. The amplitude of the secondary-side square wave voltage v_s is only 95 V, which is a quarter of the output voltage. The voltage can be stepped up to 380 V from 40 V by using a transformer with a small turns ratio $n = 2$. The experimental waveforms demonstrate the theoretical analysis pretty well. The ZVS waveforms of the primary-side active switch SP 1 and the secondary-side switch S1 are shown in above fig. Since all the primary-side switches work in the same pattern and both the secondary-side switches work symmetrically, ZVS is accomplished for all the primary-side and secondary-side active switches.

VI CONCLUSION

A novel family of IBB converters has been proposed and investigated in this paper. The IBBs are based on the nonisolated two-switch buck-boost converter, and generated by replacing the dc buck-cell and boost-cell in the nonisolated two-switch buck-boost converter by an ac buck-cell

and boost-cell. SARs are developed by merging a half-bridge circuit and a switched capacitor circuit, and used as the boost-cell in the IBB converter for high-output voltage applications. The voltage stresses on the devices in the SAR are reduced significantly, and hence, low-voltage rating devices with better conduction and switching performance have been used to improve efficiency. Furthermore, ZVS and ZCS have been achieved for all active switches and diodes, respectively, by adopting the phase-shift modulation. Operating principles, output characteristics, and soft switching performance of a novel FB-IBB converter are presented in detail. The analysis and performance have been fully validated experimentally on a 40–56-V input, 380-V output hardware prototype. Experimental results demonstrate that the proposed IBB converter is an excellent candidate for high efficiency IBB conversion in high-output voltage applications.

REFERENCES

- [1] R. Gules, J. De Pellegrin Pacheco, H. Leães Hey, and J. Imhoff, "A maximum power point tracking system with parallel connection for PV stand-alone applications," *IEEE Trans. Ind. Electron.*, vol. 55, no. 7, pp. 2674–2683, Jul. 2008.
- [2] J. Zeng, W. Qiao, L. Qu, and Y. Jiao, "An isolated multiport DC-DC converter for

- simultaneous power management of multiple different renewable energy sources,” *IEEE J. Emerg. Sel. Topics Power Electron.*, vol. 2, no. 1, pp. 70–78, Mar. 2014.
- [3] H. Wu, K. Sun, R. Chen, H. Hu, and Y. Xing, “Full-Bridge three-port converters with wide input voltage range for renewable power systems,” *IEEE Trans. Power Electron.*, vol. 27, no. 9, pp. 3965–3974, Sep. 2012.
- [4] Z. Guo, D. Sha, and X. Liao, “Input-series-output-parallel phase-shift full-bridge derived DC-DC converters with auxiliary LC networks to achieve wide zero-voltage switching range,” *IEEE Trans. Power Electron.*, vol. 29, no. 10, pp. 508–513, Oct. 2014.
- [5] H. Wu and Y. Xing, “Families of forward converters suitable for wide input voltage range applications,” *IEEE Trans. Power Electron.*, vol. 29, no. 11, pp. 6006–6017, Nov. 2014.
- [6] D. S. Gautam, F. Musavi, W. Eberle, and W. G. Dunford, “A zero-voltage switching full-bridge DC-DC converter with capacitive output filter for plug-in hybrid electric vehicle battery charging,” *IEEE Trans. Power Electron.*, vol. 28, no. 12, pp. 5728–5735, Dec. 2013.
- [7] Y. Wang, W. Liu, H. Ma, and L. Chen, “Resonance analysis and softswitching design of isolated boost converter with coupled inductors for vehicle inverter application,” *IEEE Trans. Power Electron.*, vol. 30, no. 3, pp. 1383–1392, Mar. 2015.
- [8] H. Kim, C. Yoon, and S. Choi, “An improved current-fed ZVS isolated Boost converter for fuel cell applications,” *IEEE Trans. Power Electron.*, vol. 25, no. 9, pp. 2357–2364, Sep. 2010.
- [9] Y. Zhao, W. Li, Y. Deng, and X. He, “Analysis, design, and experimentation of an isolated ZVT boost converter with coupled inductors,” *IEEE Trans. Power Electron.*, vol. 26, no. 2, pp. 541–550, Feb. 2011.
- [10] H. Keyhani and H. A. Toliyat, “Partial-resonant buck-boost and flyback DC-DC converters,” *IEEE Trans. Power Electron.*, vol. 29, no. 8, pp. 4357–4365, Aug. 2014.
- [11] C. Yao, X. Ruan, X. Wang, and C. K. Tse, “Isolated buck-boost DC/DC converters suitable for wide input-voltage range,” *IEEE Trans. Power Electron.*, vol. 26, no. 9, pp. 2599–2613, Sep. 2011.
- [12] C. Yao, X. Ruan, and X. Wang, “Automatic mode-shifting control strategy with input voltage feed-forward for full-bridge-boost DC-DC converter suitable for wide input voltage range,” *IEEE Trans. Power Electron.*, vol. 30, no. 3, pp. 1668–1682, Mar. 2015.
- [13] C. Konstantopoulos and E. Koutroulis, “Global maximum power point tracking of flexible photovoltaic modules,” *IEEE Trans.*

Power Electron., vol. 29, no. 6, pp. 2817–2828,
Jun. 2014.

AUTHOR PROFILE:



KALLEPU LAXMI BHAVANI, Pg Scholar,
Department of EEE, Vaageswari College of
Engineering, karimnagar.



Dr. M. Ramesh was born in Guntur District, Andhra Pradesh, on 07-06-1977. I completed my B.Tech. (EEE) from Viswanadtha Institute of Technology and Management affiliated Jawaharlal Nehru

Technological University, Hyderabad in 2002, M. Tech.(Advanced Power Systems) from Jawaharlal Nehru Technological University, Kakinada, Andhra Pradesh in 2005 and completed Ph.D.(Application of Artificial Intelligent Techniques for Enhancement of Stability in HVDC Transmission System) from Jawaharlal Nehru Technological University College of Engineering, Ananthapuram in 2017. I have one year of Industrial experience and 15 years of teaching experience and presently working as a Professor and HOD, EEE Dept, Vaageswari College of Engineering, karimnagar Dist. I published 30 International Journals to my credit. I published 10 International and National papers in various conferences held at India and also abroad. My research interests are AI Techniques, Power Systems & FACTS. I have Member in IEEE, Life Member of Indian Society of Technical Education (M.I.S.T.E), Life Member International Association of Computer Science and Information Technology, Life Member of International Association of Engineers, Member of Engineering Council of India (MECI)