



Avoiding Humans From Inhospitable Environments & Placing Automata

Garipalli Rojarani & D. Jhansi Rani

1. Pg scholar, Department of ECE, Annamacharya Institute of Technology And Science, Hyderabad.
2. Asst. Professor, Department of ECE, Annamacharya Institute of Technology and Science, Hyderabad.

ABSTRACT:

More particularly, calculations are developed and examined to reduce the entire quantity of Wireless access points as well as their locations in almost any given atmosphere while with the throughput needs and the necessity to ensure every place in the area can achieve a minimum of k APs. This paper concentrates on using Wireless for interacting with and localizing the robot. We've carried out thorough studies of Wireless signal propagation qualities both in indoor and outside conditions, which forms the foundation for Wireless AP deployment and communication to be able to augment how human operators communicate with this atmosphere, a mobile automatic platform is developed. Gas and oil refineries could be a harmful atmosphere for various reasons, including heat, toxic gasses, and unpredicted catastrophic failures. When multiple Wireless APs are close together, there's a possible for interference. A graph-coloring heuristic can be used to find out AP funnel allocation. Additionally, Wireless fingerprinting based localization is developed. All of the calculations implemented are examined in real life situations using the robot developed and answers are

promising. For example, within the gas and oil industry, during inspection, maintenance, or repair of facilities inside a refinery, people might be uncovered to seriously high temps to have a long time, to toxic gasses including methane and H₂S, and also to unpredicted catastrophic failures.

Keywords: *Oil & Gas, WiFi, refineries, fingerprinting.*

I. INTRODUCTION

One method to remove human exposure from these kinds of situations would be to instrument an oil refinery having a wireless sensor network, which attaches a radio sensor on every gauge and valve. Regrettably, this method is costly and labor-intensive, not to mention wireless sensors are failure prone. Getting rid of humans from inhospitable conditions is frequently desirable. Hence, upkeep of the network and reliably collecting data in the network are very challenging. We, therefore, resort to a new approach that aims to enhance the way the human operators interface using the physical world. A mobile automatic platform is really a rational



analog to some physical human it may undertake an atmosphere either autonomously or through tele-operation while sensing its surroundings together with sensors. However, further constraints are applied when presenting physical software in a gas and oil atmosphere. All products deployed must satisfy the specified standards set through the industry. Within our interdisciplinary project that aims to automate gas and oil processes utilizing a mobile robot, we've built Blaster, a mobile robot able to both tele-operation and autonomous control. Blaster is capable of doing path planning, path monitoring, obstacle avoidance, and auto inspection autonomously. Communication between Blaster and also the control station happens over Wireless. Utilizing an autonomous automatic system to have an offshore gas and oil refinery continues to be suggested before. However, no detailed studies on Wireless communication and localization issues happen to be reported. Within this paper, we concentrate on the Wireless aspects when utilizing a mobile automatic platform within an oil refinery. More particularly, we think about the two problems: Wireless communication and localization. First, as the robot is mobile, an operator must have the ability to talk to it to get sensor data collected in the refinery in addition to send it various instructions that either manipulate the robot or even the arm, request certain specific

information, or ask it to maneuver in in a certain style however, most refineries lack a radio network infrastructure. Therefore, Wireless access points should be strategically placed throughout an atmosphere to reduce the amount of models needed to attain full dental coverage plans required for communication. Second, for an automatic system to become autonomous, it has to come with an accurate knowledge of its location. Since an oil refinery frequently is composed of tall structures made from steel, Gps navigation might not continually be available, Wireless based localization becomes essential. It complements localization techniques using other sensors built-in an automatic system. The job presented within this paper helps make the following contributions. We've carried out thorough studies of Wireless signal propagation qualities both in indoor and outside conditions, which form the foundation for Wireless AP deployment and communication. We've implemented an AP positioning formula to attain single coverage. For much better reliability and localization, we've implemented a k-coverage AP positioning formula.

II. PREVIOUS STUDY

We simply discuss related operate in supplying wireless communication within an oil refinery. We defer the discussion from the work associated with specific facets of Wireless communication

and localization to later sections. Previous work provides use wireless sensor systems for remote monitoring to identify leaks of dangerous by-items of oil refineries. While WSNs can handle being outfitted together with sensors, the main lack of WSNs is battery existence in addition to their failure prone nature. An automatic mobile platform is designed to provide secure and reliable two-way wireless communication cheaper and less maintenance than the usual WSN. Localization is carried out through a kind of Synchronized Localization and Mapping. Localization is carried out through fusing the inertial navigation system and infrared sensor with reflective tapes to characterize specific formed objects. Communication is made through Wireless for an operator control station or through Bluetooth to some nearby handheld device. While both systems use Wireless for communication and localization, not one of them provide any particulars. In comparison, our work introduces an autonomous system able to localizing to some sub-meter level in indoor or outside conditions. We offer detailed discussion from the technical particulars and extensive performance studies.

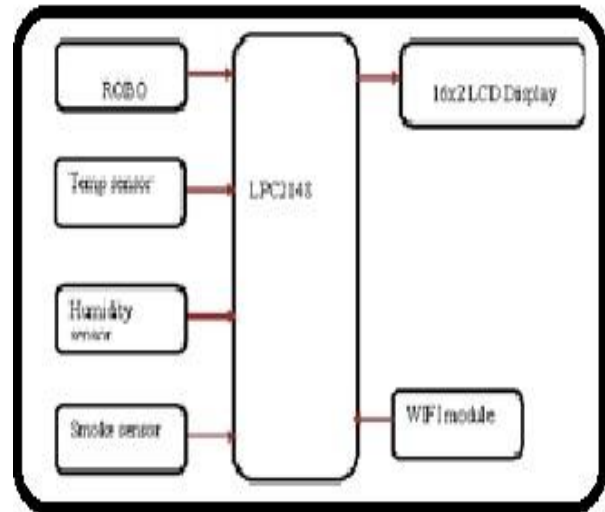

Fig.1. Block Diagram of proposed System

III. IMPLEMENTATION

Microcontroller linked to Robot and smoke, humidity and temperature sensors are linked to controller through I/O lines. Wireless module is linked to controller through serial interface. Robot can move with Wireless instructions from telnet Application. Talent obtainable in wise phone. Talent can have all sensor status in mobile application. This project uses controlled 5V 500mA power. A 7805 three terminal current regulator can be used for current regulation. Bridge type full wave rectifier can be used to rectify the ac creation of secondary of 230/12V step lower transformer. Two kinds of data are conveyed between your robot and also the control station. Control information has got the greater priority because it notifies the robot how you can act and react, i.e.: whether it's direct movement



instructions through teleportation or even more general instructions for example telling the robot of the new place to go for inspection. Tele-operation and emergency stop is a couple of procedures that need real-time communication and should be performed through the robot whatever the condition of sensor information. For instance, when the operator gets to be a report describing low pressure inside a tank, the robot should have the ability to drive upstream from the tank, start to transmit acoustic information, after which drive across the pipe to find out if there's an obvious leak. When the communication between your robot and control station occasions out, the robot halts - this really is for the utmost safety from the surrounding atmosphere as well as the robot itself. When multiple APs are situated near to one another, we have to figure out how different channels should be utilized by each AP to prevent interference. The next subsections describe the calculations employed for these reasons. When figuring out positioning of APs inside a given atmosphere, the needed minimum throughput that supports both control information and sensor information should be maintained to guarantee communication at each location within the atmosphere. This involves that anytime, the mobile robot maintain communication range with a minimum of one AP. While a dense network spread with an atmosphere is capable of this, it's

pricey. Therefore, the only-coverage Wireless AP positioning issue is to look for the minimum quantity of APs as well as their locations to ensure that each location within the atmosphere can achieve a minimum of one AP, given an area and throughput needs per the applying. Since the Wireless infrastructure continues to be deployed, we are able to apply it localization. Indoor Wireless localization continues to be analyzed extensively supplies a survey of wireless indoor positioning techniques. When carrying out localization via a Wireless network, two approaches are usually taken: signal propagation modeling and Wireless fingerprinting. A gas and oil refinery could be regarded as a mix of both an inside as well as an outside atmosphere because of the nature from the layout, so a number of studies were carried out to know how Wireless signals propagate both in indoor and outside conditions. Particularly, we read the impact of distance, transmission power, or speed from the mobile robot around the lower and upper bounds of received signal strength indicator, bandwidth, and packet delivery ratio.

IV. CONCLUSION

In this particular work we define the types of communication required to deploy an autonomous robot. For just about any automatic system to autonomously navigate inside a coal and oil

refinery, it needs to be capable of speak with the control room in addition to localize itself. Wireless fingerprinting based localization was created that achieves a suitable precision when utilized by it and achieves preferred precision when combined with INS and fiducially marker based approach. We study Wireless signal propagation characteristics and employ the findings to discover Wireless AP positioning. We assign channels to interfering APs.

REFERENCES

[1] B. Graf and K. Pfeiffer, "Mobile robotics for offshore automation," Proceedings of the EURON/IARP International Workshop on Robotics for Risky Interventions and Surveillance of the Environment, Benicassim, Spain, 2008.

[2] D. Plets, W. Joseph, K. Vanhecke, E. Tanghe, and L. Martens, "On Coverage Prediction and Optimization Algorithms for Indoor Environments," EURASIP Journal on Wireless Communications and Networking, vol. 2012, no. 123, 2012.

[3] Z. Zhou, S. Das, and H. Gupta, "Connected K-Coverage Problem in Sensor Networks," in Computer Communications and Networks, 2004.

[4] R. Palaniappan, P. Mirowski, T. K. Ho, H. Steck, P. Whiting, M. Macdonald, A.-l. B. Labs, M. Avenue, and M. Hill, "Autonomous rf surveying robot for indoor localization and tracking," International Conference on Indoor Positioning and Indoor Navigation (IPIN), September 2011.

[5] H. Liu, S. Member, H. Darabi, P. Banerjee, and J. Liu, "Survey of Wireless Indoor Positioning Techniques and Systems," vol. 37, no. 6, pp. 1067–1080, 2007.

AUTHOR'S PROFILE:



NAME: GARIPALLI ROJARANI

MASTER OF TECHNOLOGY (M.TECH STUDENT)

MAIL ID: rojarani.garipally@gmail.com

ANNAMACHARYA INSTITUTE OF TECHNOLOGY
AND SCIENCES.

Piglipur, Blatasingaram, Hayat nagar, Ranga Reddy District,
Hyderabad, Telangana- 501512.



Name: D. JHANSI RANI
Designation: Asst. Professor, M.Tech

College: ARJUN COLLEGE OF TECHNOLOGY AND SCIENCES, JNTUH
email: jhansirani.dasari@gmail.com

ANNAMACHARYA INSTITUTE OF TECHNOLOGY AND SCIENCES.

Piglipur, Blatasingaram, Hayat nagar, Ranga Reddy District, Hyderabad, Telangana- 501512.