

# Development Of Manufacturing Palm Of Tooth Wheel Used In Metro Trains

Gurram Sharon Rose, M.Tech & G Koti Reddy, Associate Professor

Nova College Of Engineering & Technology, Jafferguda Batasingaram (V), Hayath Nagar (M), Ranga Reddy (Dist)

## ABSTRACT

*Tooth wheel are reliable gears used for higher transmission. It is similar to gears which are used for transmission of power. This type of gears are used at higher proportions rate of transmission where required like electrical locomotives (metros), flight braker system.*

*The aim of the project is to design and Manufacture of tooth wheel, As the process the tooth wheel are manufacturing by using face mill cutter there may chance of using fixture for tooth wheel. The 3D model of **tooth wheel** is created in NX-CAD software and NC program is generated on 3D model of **tooth wheel**. Generated NC program is fed to CNC machine through DNC lines. Finally, tooth wheel is manufactured using NC program which is generated in NX-CAM software.*

## INTRODUCTION

### CAD:

CAD is computer aided designing or computer aided drafting. CAD is used for developing the 3d model from the 2d input. It is also used to drafting sheets which are used to inspection. CAD software has different modules. They are:

1. Modeling
2. Assembly
3. Drafting
4. Sheet metal
5. Piping
6. Shape studio
7. Welding

### CAM:

CAM is computer aided manufacturing. In cam software, the processes from selection of raw

material to NC program generation were done. Finally NC program was optimized using post builder and given to the machine. Generally, process involved in the CAM software.

1. Selection of raw material
2. Selection of machine
3. Selection of tools
4. Selection of process
5. Sequencing of the processes
6. Generation of the NC program
7. Optimization of the NC program

### NUMERICAL CONTROL:

Numerical control is refers to the program generated by using commands and operated manually by using levers or handles by operators.

### CNC:

CNC stands computer numerical control. In this the program was generated with aid of computer and given to the machine and operations are controlled by computer.

### CAE:

CAE is computer aided engineering. In CAE software, the component is analyzed for engineering appliances i.e. real time appliances. Based on the application, the component is analyzed. Optimization is done on the component based on the requirements. Optimizations are done in the following ways.

1. Selection of alternative material
2. Addition of the material to the component.

### 3D MODELING OF TOOTHED WHEEL

#### 2d drawing:

Below shows the 2d drawings of the toothed wheel with all the required dimensions.

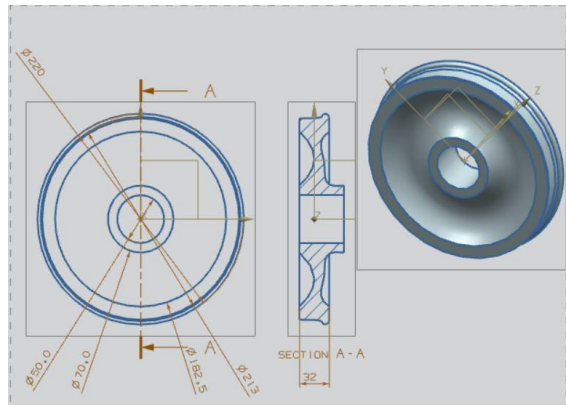

**Steps involved in 3d modeling of toothed wheel:**

**Sketching:**

Below image shows the **sketch** of the toothed wheel.

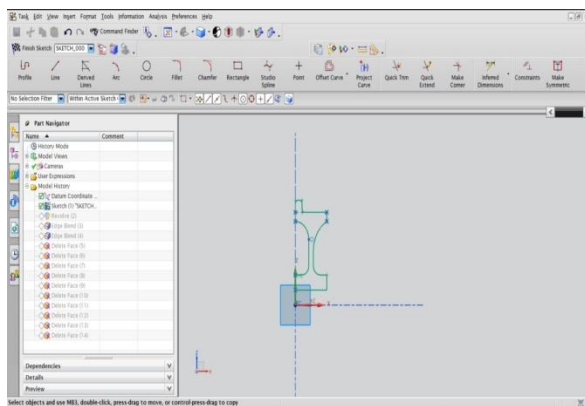

**Revolve:**

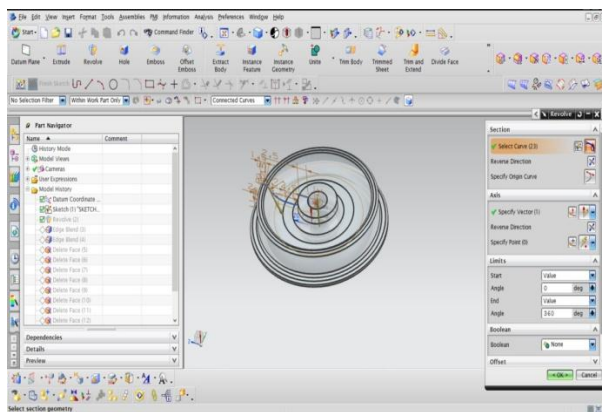

**Final component:**

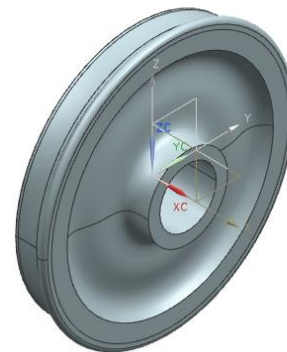
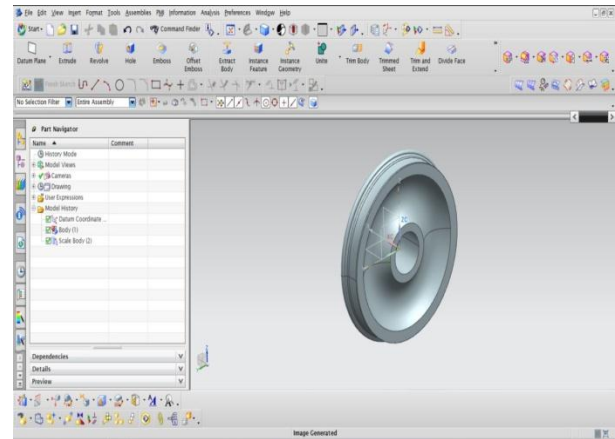

Fig shows isometric view-1 of the toothed wheel

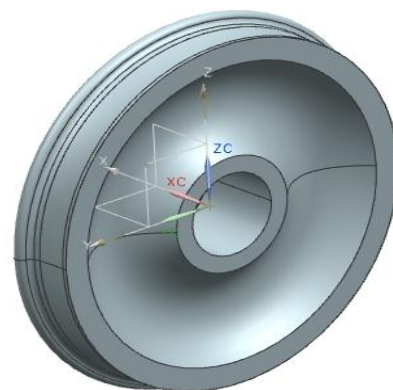

Fig shows isometric view-2 of the toothed wheel

## COMPUTER AIDED MANUFACTURING (CAM)

The main objective of the project is to obtain to reduce machining errors and collision of tools and rotary table by developing virtual kit.

**Methodology of manufacturing toothed wheel.**

- Identify suitable machine.
- Selecting suitable tools for manufacturing toothed wheel component.
- Selection of fixture.
- Listing down the sequence of operation performed on toothed wheel component.
- Generating tool path at specified cutting speed.
- Generating NC program using NX-cam software.

**Identification of suitable machine:**

Types of CNC machine used in this project

**For toothed wheel 5-axis milling machine is used**



**Selection of tools:**

Suitable tools for manufacturing are listed below

- spot drilling
- drilling
- tapping
- face milling
- face\_milling\_area
- End mill
- roughing end mill

**Steps involved in generation of tool path:**

**Face milling:**

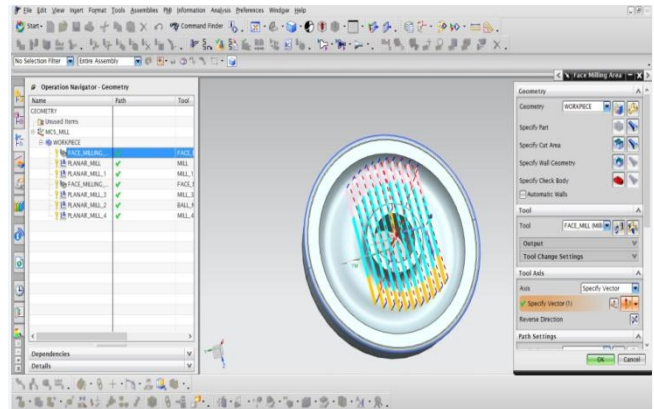

Fig shows tool path generation of face milling for toothed wheel

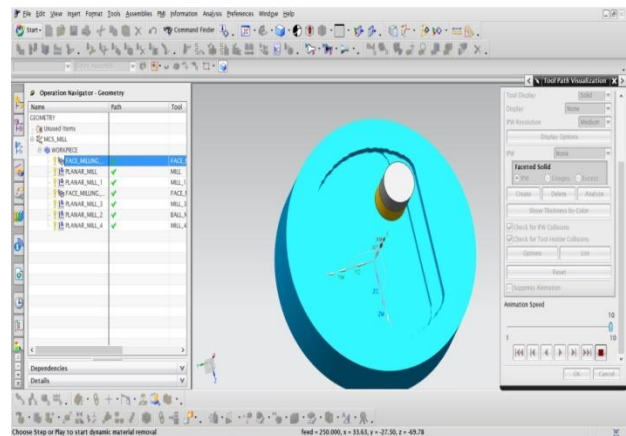

Fig shows tool path verification of face milling for toothed wheel

**Planar milling:**

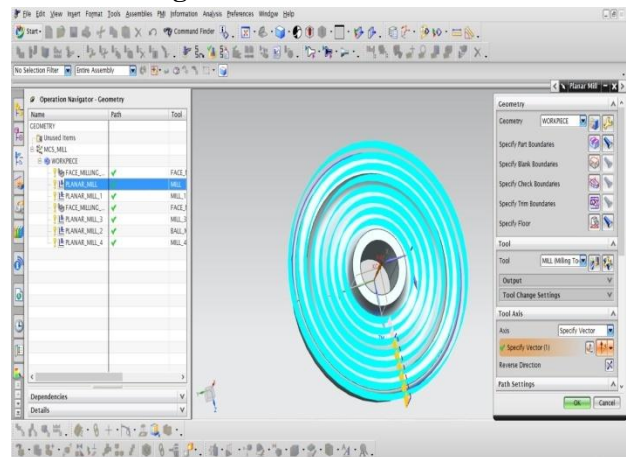

Fig shows tool path generation of planar milling for toothed wheel

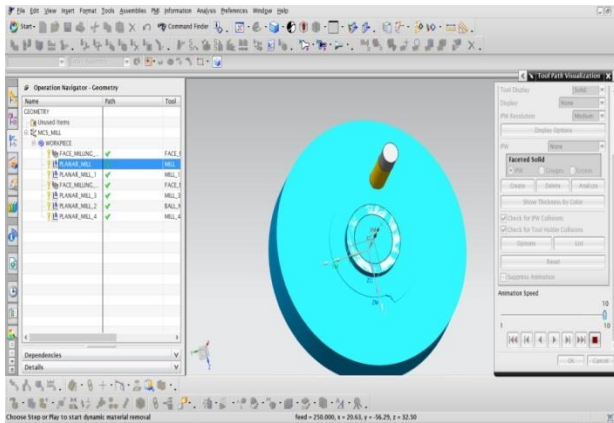

Fig shows tool path verification of planar milling for toothed wheel

Fig shows tool path verification of planar milling for toothed wheel  
**Planar milling:**

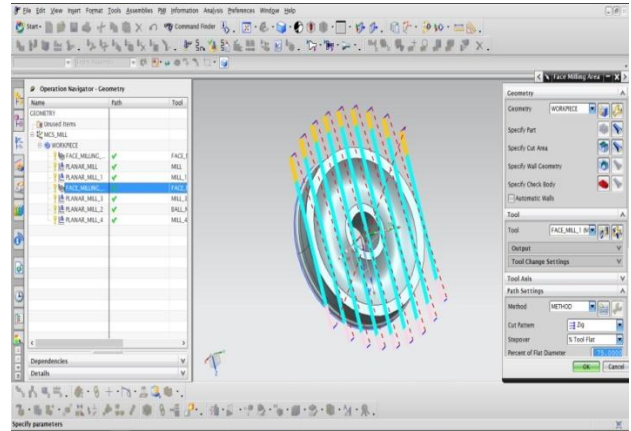

Fig shows tool path generation of planar milling for toothed wheel

**Planar milling:**

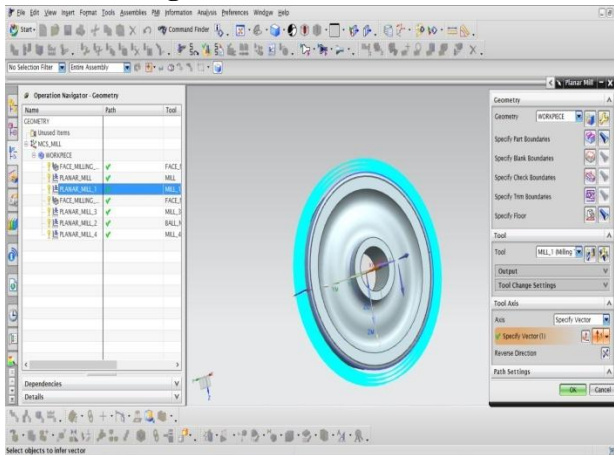

Fig shows tool path generation of planar milling for toothed wheel

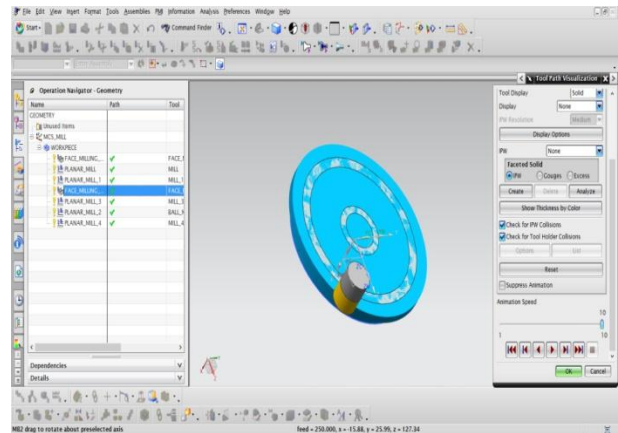

Fig shows tool path verification of planar milling for toothed wheel

**Planar milling:**

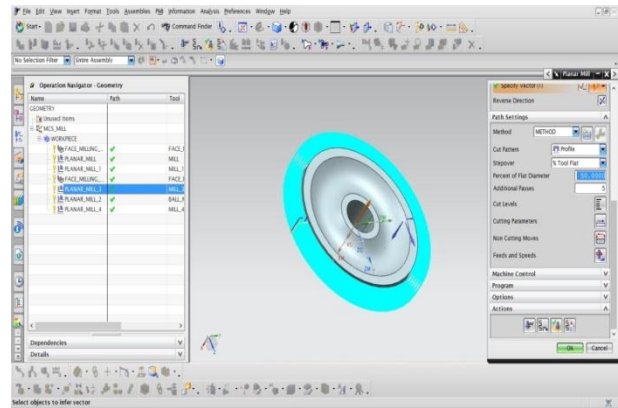
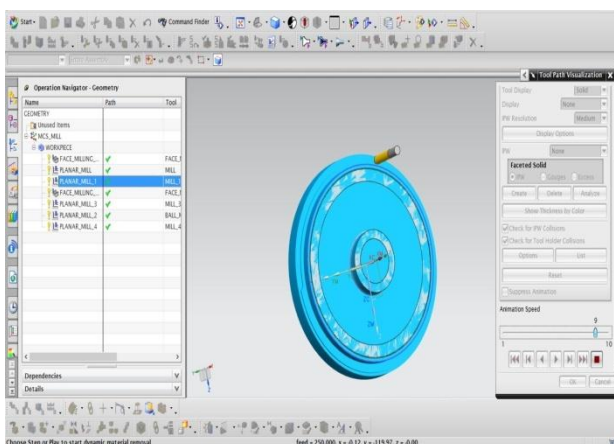

Fig shows tool path generation of planar milling for toothed wheel

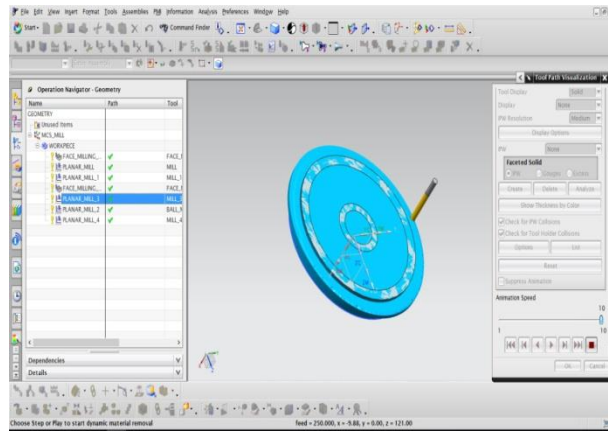

Fig shows tool path verification of planar milling for toothed wheel

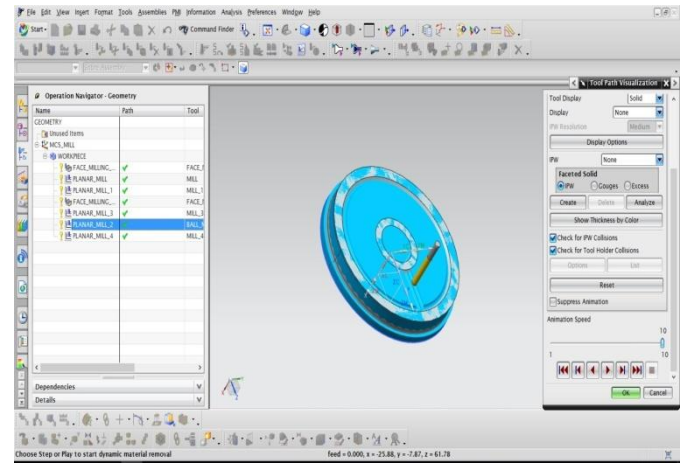

Fig shows tool path verification of planar milling for toothed wheel

### Planar milling:

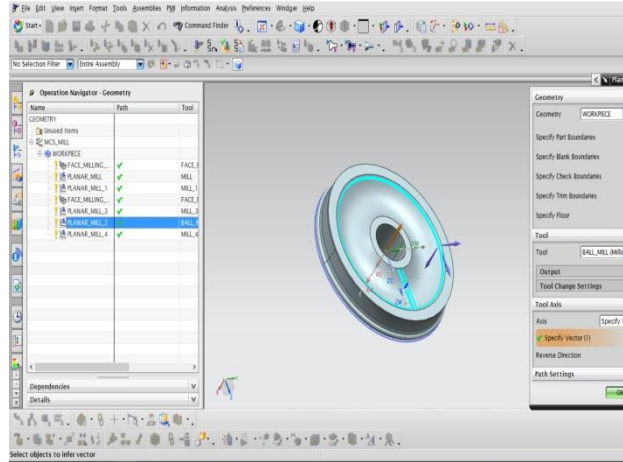

Fig shows tool path generation of planar milling for toothed wheel

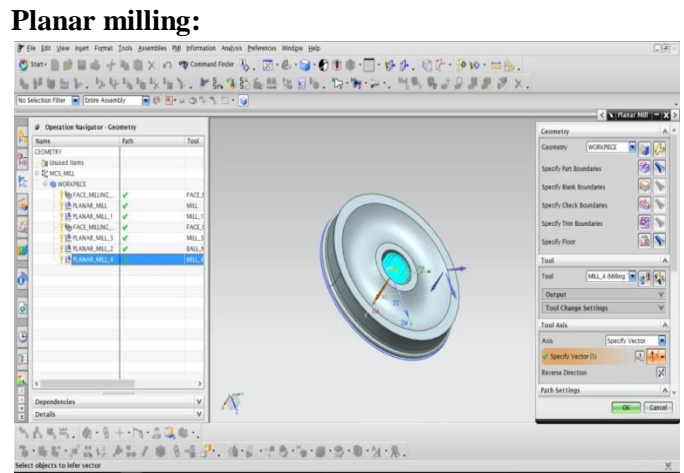

Fig shows tool path generation of planar milling for toothed wheel

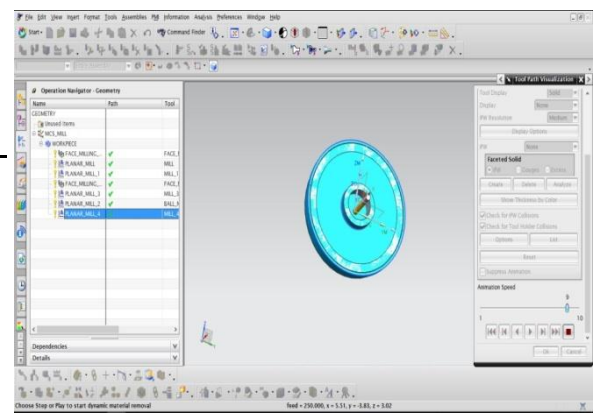

Fig shows tool path verification of planar milling for toothed wheel

---

## CONCLUSION

- 3D model of Toothed wheel is created using UGNX-7.5 –CAD.
- Tool path is generated for “Toothed wheel” component using CAM software (‘UGNX-7.5’ which is CAD/CAM software used to generate part program by designing and feeding the geometry of the component).
- The generated part program will be transferred to the required CNC machine with the help of DNC lines.
- Final component of toothed wheel is manufactured by above generated NC program.

## REFERENCES

- Instability Analysis in Curve Noise of Urban Railway Systems for Optimal Steering Bogie Development.
- Rolling Condition and Gyroscopic Moments in Curve Negotiations.
- Liszewski, Andrew (15 March 2017). "The Reason Trains Have Angled Wheels Is Incredibly Clever". Gizmodo. Retrieved 14 March 2017. ISO 1005 Parts 1-9 BS 5892 Parts 1-6 AS7414.4
- Rail profile : definition razorbackrailway.com
- Message in the mailing list '1520 mm' on P75 rails".
- Raymond, William G., The Elements of Railroad Engineering, 5th Edition, John Wiley and Sons, 1937
- Urquhart, Leonard Church, Civil Engineering Handbook, 4th Edition, McGraw-Hill Book Company, 1959
- D.D. Hagarty (February 1999). "A Short History of Railway Track in Australia - 1 New South Wales". Australian Railway Historical Society Bulletin: 55–67.