

Improve The Lifetime Of Network By The Affect Of Mitigating The Hop Count.

K Rakesh

Assistant professor Department of Electronics and Communication Engineering
Joginpally BR Engineering College, Hyderabad, Telangana, India.

Abstract:

In this study, we've an inclination to gift a singular family of mixed number programming (MIP) models to research the results of limiting hop figure Wireless detector Network (WSN) fundamental quantity. we've an inclination to performed analysis to uncover the trade-off between minimizing the quantity of hops and increasing the network fundamental quantity by exploring the parameter space through numerical evaluations of the development models. Our results reveal that minimum hop routing leads to vital decrease in network fundamental quantity (up to 40%) once place next to the foremost network fundamental quantity obtained with none restrictions on hop count. However, the decrease in network fundamental quantity is negligible if the minimum hop routing criterion is modestly relaxed.

Introduction:

WIRELESS detector networks (WSNs) contains small kind issue detector nodes that unit of measurement densely deployed over a countryside to watch physical phenomena like temperature, pressure, humidity. Prolonging network amount by economical use of restricted battery energy may well be a central issue in WSN vogue. Communication connected tasks dominate the energy budget of WSNs. Communication energy consumption are going

to be optimized through transmission power management, energy equalization routing, and sleep-wake up coming up with protocols. Minimum hop routing may well be a large used technique in WSNs, where detector nodes send their info to all-time low station by exploitation the path that is comprised of the minimum form of relay nodes. moreover, minimum hop routing approach is used as a result of the baseline case for examination the performance of WSN routing techniques in many studies. In fact, the common observation in these studies on minimum hop routing is that it's potential attainable} uphill unthinkable out of the question impossible out of the question unacceptable unworkable unrealizable unworkable impractical} to realize the utmost network amount possible given a WSN activity by exploitation minimum hop routing. Indeed, there is a exchange between minimizing the hop count and increasing the network amount in WSNs. By minimizing the hop count some nodes unit of measurement forced to carry excessive amount of traffic and run out of battery energy speedily. By relaxing the minimum hop count constraint, overuse of such nodes is alleviated. all constant,

the extent of the loss of amount due to minimum hop routing and additionally the extent of relaxation on hop count constraint to maximise network amount haven't been investigated systematically in WSN literature.

Sensor Networks:

WIRELESS detector networks (WSNs) accommodates tiny kind issue detector nodes that area unit densely deployed over a geographic area to observe physical phenomena like temperature, pressure, humidity. Prolonging network period by economical use of restricted battery energy may be a central issue in WSN style. Communication connected tasks dominate the energy budget of WSNs. Communication energy consumption will be optimized through transmission power management, energy equalization routing, and sleep-wake up programing protocols. Minimum hop routing may be a wide used technique in WSNs, wherever detector nodes send their information to the bottom station by victimisation the trail that's comprised of the minimum range of relay nodes. moreover, minimum hop routing approach is employed because the baseline case for comparison the performance of WSN routing techniques in several studies. In fact, the common observation in these studies on minimum hop routing is that it's doable impossible uphill inconceivable unimaginable insufferable out of the question unacceptable impracticable unattainable unfeasible impractical} to realize the utmost network period possible given a WSN readying by victimisation minimum hop routing. Indeed, there's a trade-off between minimizing the hop count and increasing the network period in WSNs. By minimizing the hop count some nodes area unit forced to hold excessive quantity of traffic and run out of battery energy apace. By

quiet the minimum hop count constraint, overutilisation of such nodes is mitigated . all the same, the extent of the loss of period because of minimum hop routing and therefore the level of relaxation on hop count constraint to maximise network period haven't been investigated consistently in WSN literature.

The major contributions of this paper are the following:

- 1) What is the extent of network period decrease because of minimum hop routing with reference to the most network period doable with none constraints on network lifetime?
- 2) what proportion relaxation on hop count is important to attain the most network lifetime?
- 3) Is it potential to attain close to most network period by quiet the hop count modestly?

Message authentication: The message receiver got to be able to verify whether or not or not a received message is shipped by the node that is claimed or by a node throughout a specific cluster. In different words, the adversaries cannot faux to be Associate in Nursing innocent node and inject fake messages into the network whereas not being detected.

Message integrity: The message receiver got to be able to verify whether or not or not the message has been modified en-route by the adversaries. in several words, the adversaries cannot modify the message content whereas not being detected.

Hop-by-hop message authentication: each forwarder on the routing path got to be able to verify the believability and integrity of the messages upon reception.

Architectural Diagram:

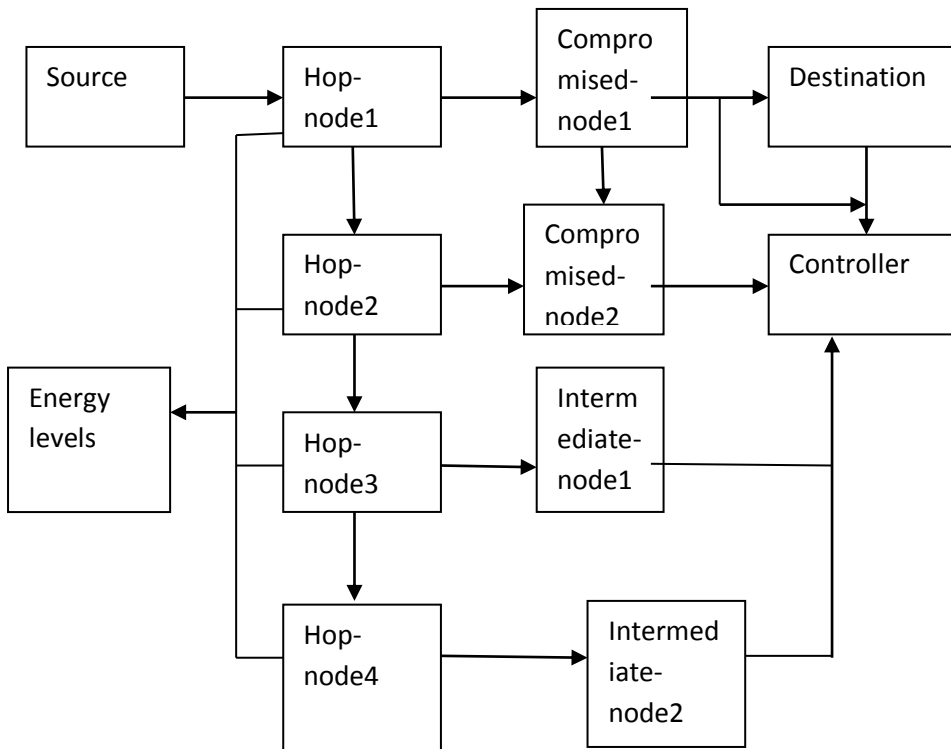

Existing System:

- 1) Limiting hop count using MIP framework
- 2) Network lifetime in network process

Disadvantages:

- 1) Hop counts more
- 2) Network lifetime 30% only
- 3) Energy levels less in process

Proposed System:

- 1) Focus on decrease hop count and increase network lifetime
- 2) Developing MIP framework with individual nodes
- 3) Generate the energy levels for each node

Advantages:

- 1) Network lifetime more aggregate as 65%
- 2) Hop count values decreases completely
- 3) Delivery ratio more

- 4) Energy consumption less

HARDWARE REQUIREMENTS:

System: Pentium IV 2.4 GHz.

Hard Disk: 50 GB.

Floppy Drive: 1.44 Mb.

Monitor: 18 VGA Color.

Mouse: Logitech.

Ram: 2048 Mb.

Software Requirements:

Operating system: Ubuntu 14.04

Coding Language: otcl, c++

Tool: Ns-2.35

Simulation results:

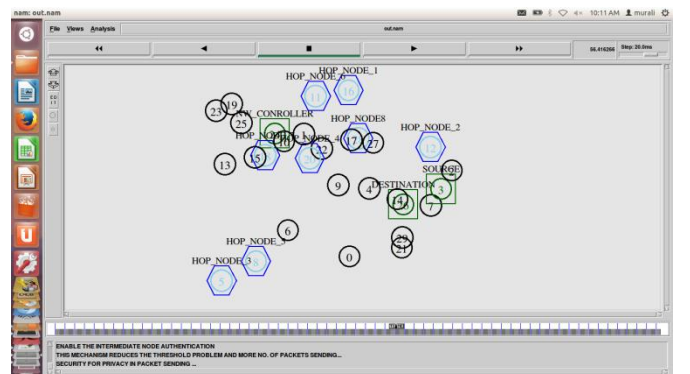
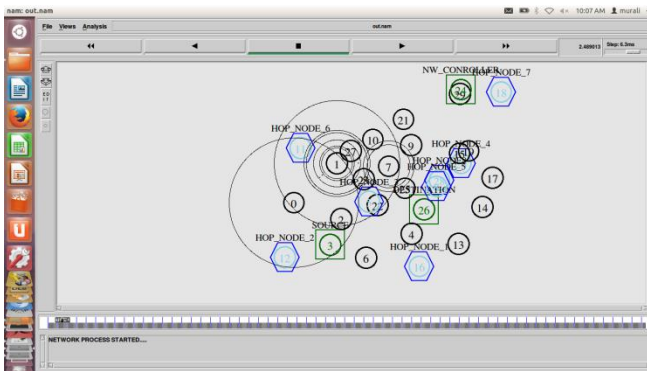
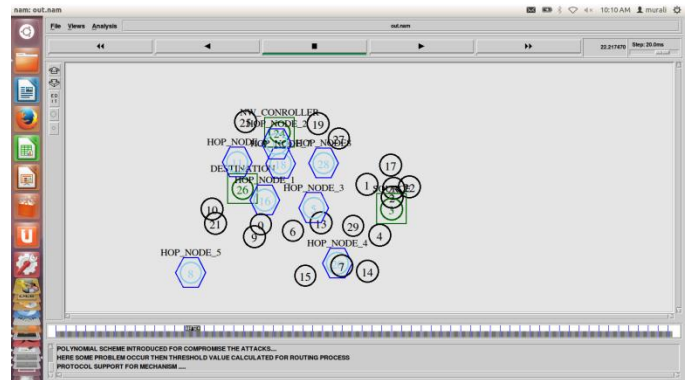
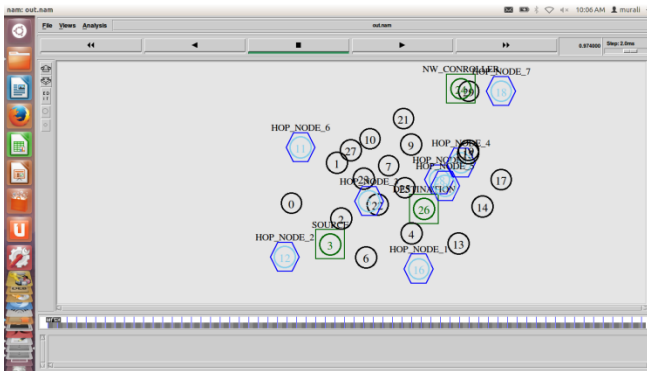
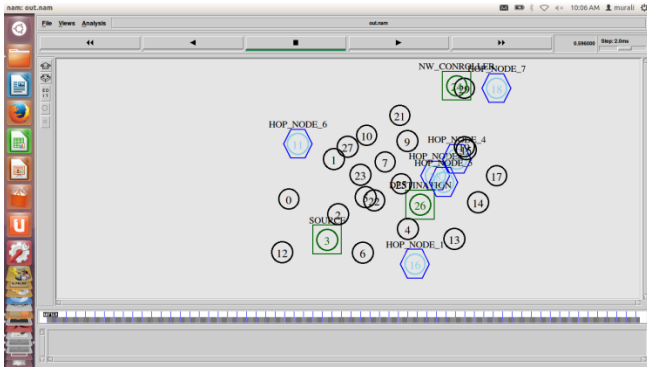

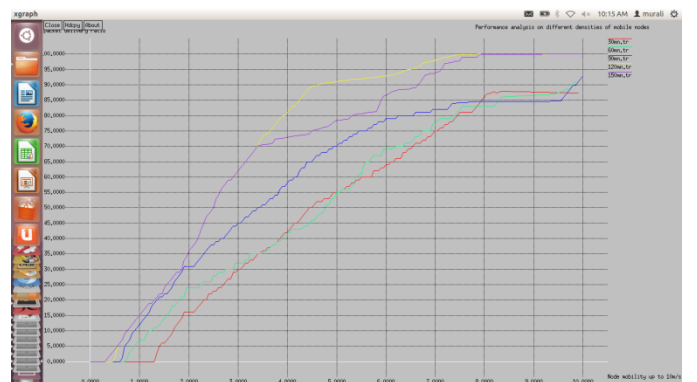
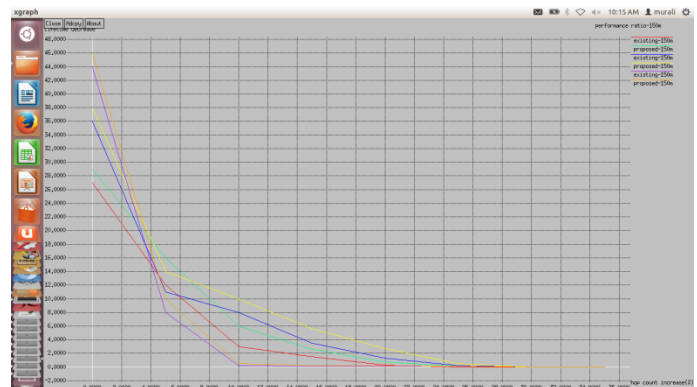
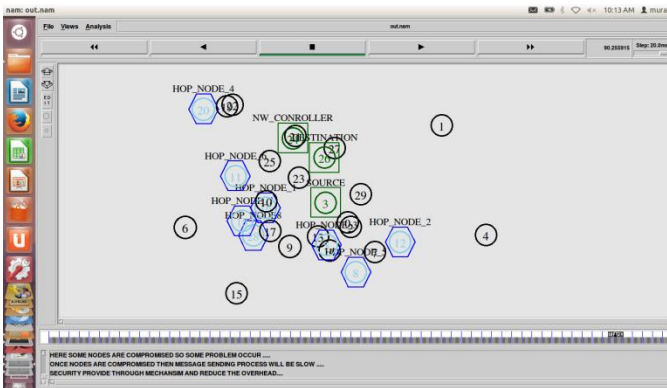
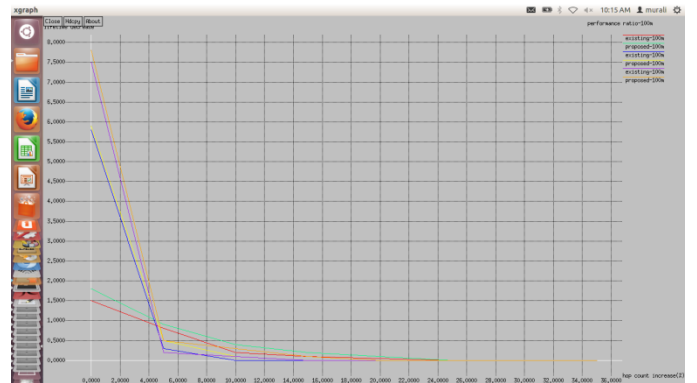
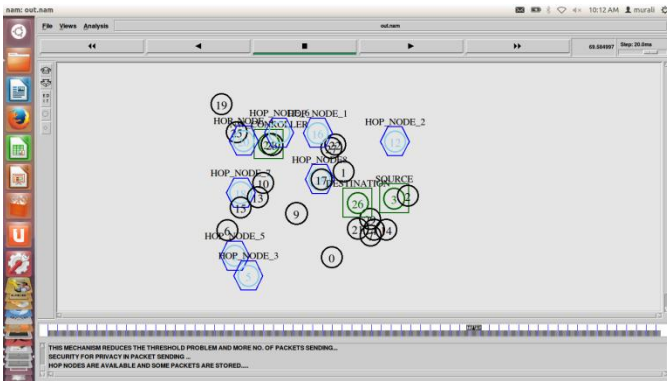

Simulation graphs:

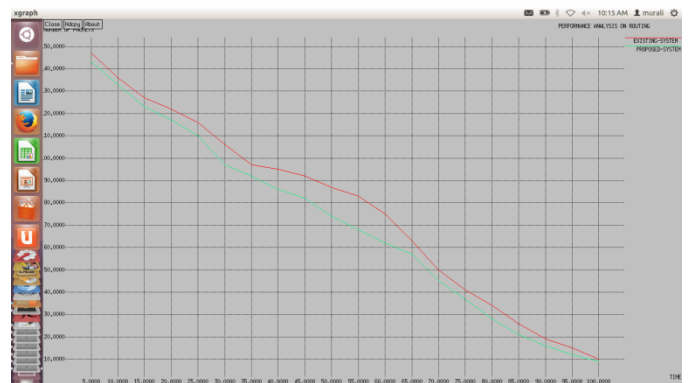
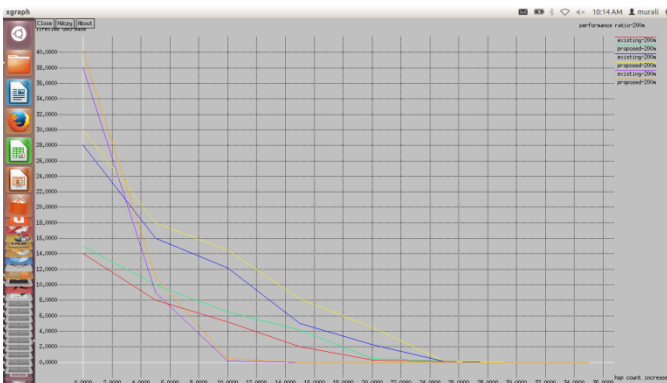

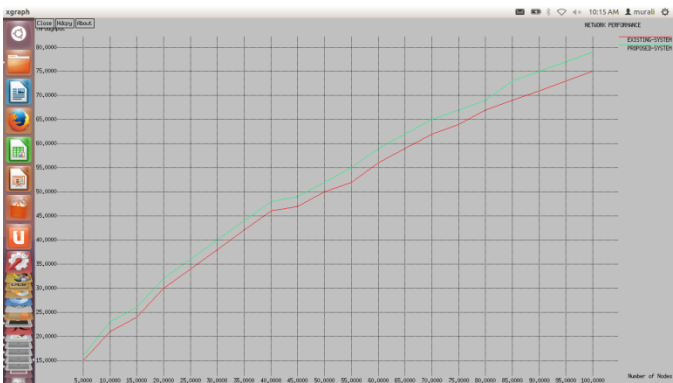
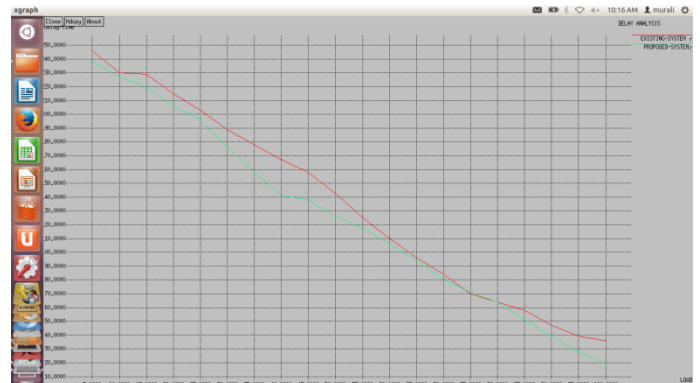
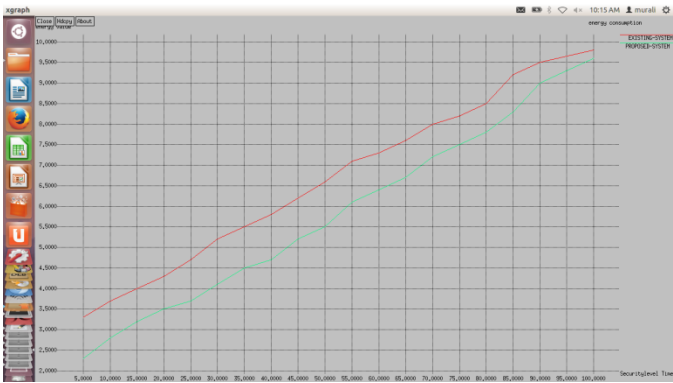

Conclusion:

In this study, we've a bent to gift a very distinctive MIP framework to analysis the impact of limiting hop estimate WSN amount of your time to a lower place best operative conditions. we've a bent to explored the parameter space through numerical evaluations of the MIP models to characterize the results of minimum hop routing on network amount of your time. moreover, we've a bent to analyze the extent of relaxation on minimum hop count constraint to comprehend the utmost network amount of your time. Our results show that limiting the hop count to the minimum worth has important effects on network amount of your time (e.g., minimum hop routing could end in further than ordinal decrease in network amount of your time with reference to the network amount of your time obtained whereas not limiting the hop count). to comprehend the utmost network amount of your time, up to thirty second increase of the minimum hop count is also needed counting on the network area and style of nodes inside the network. However, it's accomplishable to urge insignificant amount of your time decreases with moderate can increase inside the minimum hop count (e.g., at the foremost membered decrease in network amount of your time with one hundred pc increase inside the hop count).

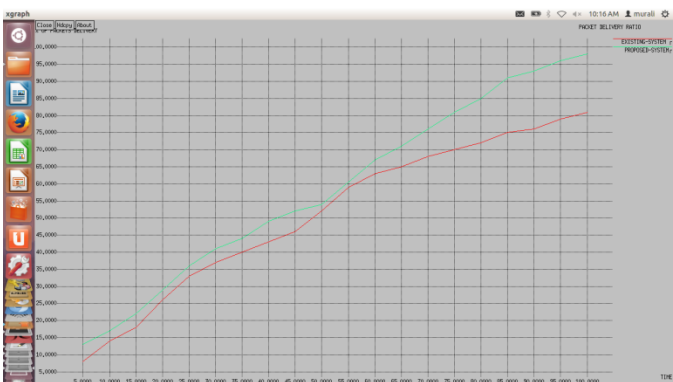

References:

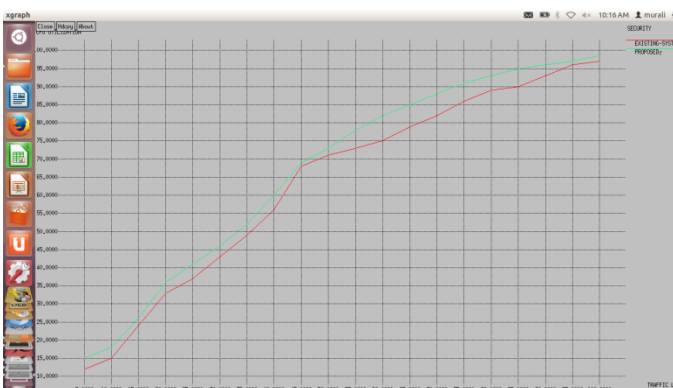

- [1] K. Akkaya and M. Younis, "A survey on routing protocols for wireless sensor networks," *Ad Hoc Netw.*, vol. 3, no. 3, pp. 325–349, 2005.
- [2] Z. Cheng, M. Perillo, and W. Heinzelman, "General network lifetime and cost models for evaluating sensor network deployment strategies," *IEEE Trans. Mobile Comput.*, vol. 7, no. 4, pp. 484–497, Apr. 2008.
- [3] M. Rahimi *et al.*, "Cyclops: in situ image sensing and interpretation in wireless sensor networks," in *Proc. ACM Conf. Embedded Netw. SenSys*, 2005, pp. 192–204.
- [4] S.-S. Chiang, C.-H. Huang, and K.-C. Chang, "A minimum hop routing protocol for home security systems using wireless sensor networks," *IEEE Trans. Consum. Electron.*, vol. 53, no. 4, pp. 1483–1489, Nov. 2007.
- [5] B. Nazir, H. Hasbullah, and S. A. Madani, "Sleep/wake scheduling scheme for minimizing end-to-end delay in multi-hop wireless sensor networks," *EURASIP J. Wireless Commun. Netw.*, vol. 2011, pp. 92:1–92:14, 2011.
- [6] K. N. Kannan and B. Paramasivan, "Development of energy-efficient routing protocol in wireless sensor networks using optimal gradient routing with on demand

neighborhood information," *Int. J. Distrib. Sensor Netw.*, vol. 2014, 2014, Art. ID. 208023.

- [7] A. Capone, M. Cesana, D. DeDonno, and I. Filippini, "Deploying multiple interconnected gateways in heterogeneous wireless sensor networks: An optimization approach," *Comput. Commun.*, vol. 33, no. 10, pp. 1151–1161, Jun. 2010.

- [8] J. Kim, X. Lin, N. Shroff, and P. Sinha, "Minimizing delay and maximizing lifetime for wireless sensor networks with anycast," *IEEE/ACM Trans. Netw.*, vol. 18, no. 2, pp. 515–528, Apr. 2010.

Author Profile:



Sri.Kolluri Rakesh, currently working as an Assistant Professor, in the Department of Electronics and communication Engineering, Joginpally B.R Engineering college, Moinabad, Rangareddy Dist, Hyderabad, Telangana, India. He studied B.TECH (ECE) from J.B.R.E.C, JNTU University, Hyderabad and M.Tech(WIRELESS MOBILE COMMUNICATION) from, AHTC JNTU University, Hyderabad, India. He is having 1+ years of work experience in Academics, Teaching..