

A General Overview of Multiplexer and Demultiplexer

Ankit Dalal^{1*} & Ankur Atri²

Department of Information Technology, Computer Science and Information Technology,
Dronacharya College of Engineering, Gurgaon-122001, India

*E-mail: ankit.16898@ggnindia.dronacharya.info, ankur.16900@ggnindia.dronacharya.info

Abstract:

This research paper is a general overview of Mux and Demux. This research paper has a brief introduction about these electronic devices. A multiplexer or data selector is a device that is capable of taking two or more data lines and converting them into a single data line for transmission to another point. A demultiplexer or data distributor is used to convert a single, multiplexed data transmission line back

into separate data signals. In this 1 to 4 multiplexer and demultiplexer are discussed. Various applications of mux and demux in the field of telephone, satellite communication are also discussed along with uses in computer science.

Keywords:

Enable; telephony; switching ; control input ; encryption

Introduction

In telecommunications and computer networks, multiplexing (sometimes contracted to muxing) is a method by which multiple analog message signals or digital data streams are combined into one signal over a shared medium. The aim is to share an expensive resource. For example, in telecommunications, several telephone calls may be carried using one wire. Multiplexing originated in telegraphy in the 1870s, and is now widely applied in communications. In telephony, George Owen Squier is credited with the development of telephone carrier multiplexing in 1910. Demultiplexer means

one to many. A demultiplexer is a circuit with one input and many output. By applying control signal, we can steer any input to the output. Few types of demultiplexer are 1-to-2, 1-to-4, 1-to-8 and 1-to-16 demultiplexer[1].

Multiplexer

Multiplexer means many into one. A multiplexer is a circuit used to select and route any one of the several input signals to a signal output. A simple example of a non-electronic circuit of a multiplexer is a single pole multiposition switch.

Multiposition switches are widely used in many electronics circuits. However circuits that operate at high speed require the multiplexer to be automatically selected. A mechanical switch cannot perform this task satisfactorily. Therefore, multiplexer used to perform high speed switching are constructed of electronic components.

Multiplexer handle two type of data that is analog and digital. For analog application, multiplexer are built of relays and transistor switches. For digital application, they are built from standard logic gates.

The multiplexer used for digital applications, also called digital multiplexer, is a circuit with many input but only one output. By applying control signals, we can steer any input to the output. Few types of multiplexer are 2-to-1, 4-to-1, 8-to-1, and 16-to-1 multiplexer.

The general form of a multiplexer is shown in the figure:

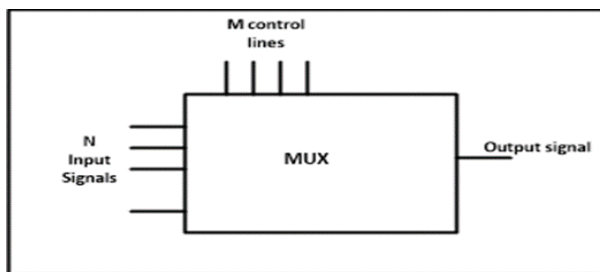

Figure 1: Multiplexer Pin Diagram

The 4-to-1 multiplexer has 4 input bit, 2 control bits, and 1 output bit. The four input bits are D0, D1, D2 and D3. Only one of this is transmitted to the output y. The output

depends on the value of AB which is the control input[2]. The control input determines which of the input data bit is transmitted to the output.

For instance, as shown in fig. when $AB = 00$, the upper AND gate is enabled while all other AND gates are disabled. Therefore, data bit D0 is transmitted to the output, giving $Y = D_0$.

The below figure illustrates a 4:1 multiplexer circuit diagram:

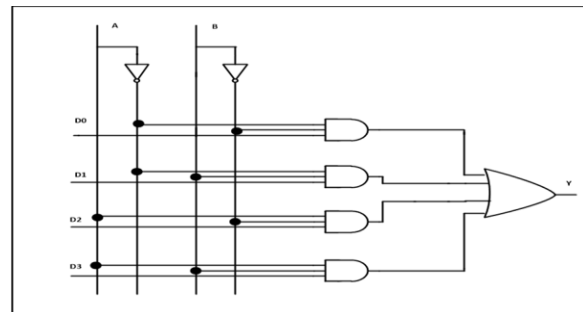

Figure 2: 4 to 1 Multiplexer Circuit Diagram

Applications of Multiplexer

Multiplexer are used in various fields where multiple data need to be transmitted using a single line. Following are some of the applications of multiplexers:

1. Communication system: Communication system is a set of system that enable communication like transmission system, relay and tributary station, and communication network. The efficiency of communication system can be increased considerably using multiplexer. Multiplexer allow the

process of transmitting different type of data such as audio, video at the same time using a single transmission line.

2. Telephone network: In telephone network, multiple audio signals are integrated on a single line for transmission with the help of multiplexers. In this way, multiple audio signals can be isolated and eventually, the desire audio signals reach the intended recipients.
3. Computer memory: Multiplexers are used to implement huge amount of memory into the computer, at the same time reduces the number of copper lines required to connect the memory to other parts of the computer circuit.
4. Transmission from the computer system of a satellite: Multiplexer can be used for the transmission of data signals from the computer system of a satellite or spacecraft to the ground system using the GPS (Global Positioning System) satellites[3].

Use of multiplexer in Telephone Communication

As stated before, in telephone network, multiple audio signals are integrated on a single line for transmission with the help of multiplexers. In this way, multiple audio signals can be isolated and eventually, the desire audio signals reach the intended recipients. When all these multiple signals

are integrated, they form a combined signal which have greater strength to travel more distance easily and has less chances of it to get distorted easily.

By the help of these Multiplexers in our communication lines, we get a clear voice even when we call someone in a long distance.

For coverage of a long distance a chain of multiplexers are used so that to ensure more stability of signal and also to make sure that the signal don't get distorted in between the communication line.

Demultiplexer

Demultiplexer means one to many. A demultiplexer is a circuit with one input and many output. By applying control signal, we can steer any input to the output. Few types of demultiplexer are 1-to 2, 1-to-4, 1-to-8 and 1-to 16 demultiplexer.

Following figure illustrate the general idea of a demultiplexer with 1 input signal, m control signals, and n output signals[4].

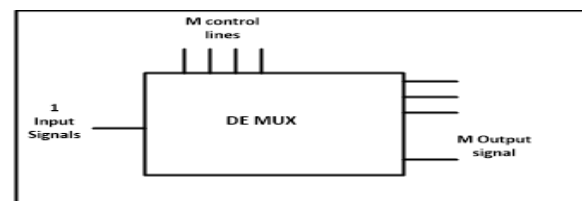

Figure 3: Demultiplexer Pin Diagram

Understanding 1- to-4 Demultiplexer

The 1-to-4 demultiplexer has 1 input bit, 2 control bit, and 4 output bits. An example

of 1-to-4 demultiplexer is IC 74155. The 1-to-4 demultiplexer is shown in figure below:

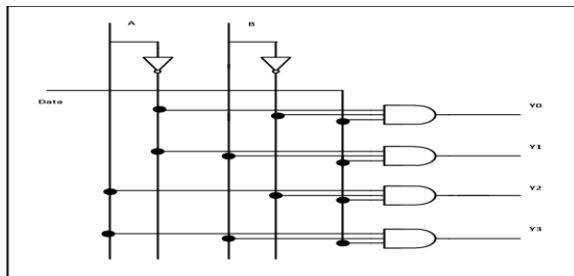

Figure 4: 1 to 4 Demultiplexer Circuit Diagram

The input bit is labelled as Data D. This data bit is transmitted to the data bit of the output lines. This depends on the value of AB, the control input.

When $AB = 01$, the upper second AND gate is enabled while other AND gates are disabled. Therefore, only data bit D is transmitted to the output, giving $Y1 = \text{Data}$.

If D is low, Y1 is low. If D is high, Y1 is high. The value of Y1 depends upon the value of D. All other outputs are in low state.

If the control input is changed to $AB = 10$, all the gates are disabled except the third AND gate from the top. Then, D is transmitted only to the Y2 output, and $Y2 = \text{Data}$.

Example of 1-to-16 demultiplexer is IC 74154 it has 1 input bit, 4 control bits and 16 output bit.

Applications of Demultiplexer

1. Demultiplexer is used to connect a single source to multiple destinations. The main application area of

demultiplexer is communication system where multiplexer are used. Most of the communication system are bidirectional i.e. they function in both ways (transmitting and receiving signals). Hence, for most of the applications, the multiplexer and demultiplexer work in sync. Demultiplexer are also used for reconstruction of parallel data and ALU circuits.

2. Communication System: Communication system use multiplexer to carry multiple data like audio, video and other form of data using a single line for transmission. This process make the transmission easier. The demultiplexer receive the output signals of the multiplexer and converts them back to the original form of the data at the receiving end. The multiplexer and demultiplexer work together to carry out the process of transmission and reception of data in communication system.
3. ALU (Arithmetic Logic Unit): In an ALU circuit, the output of ALU can be stored in multiple registers or storage units with the help of demultiplexer. The output of ALU is fed as the data input to the demultiplexer. Each output of demultiplexer is connected to multiple register which can be stored in the registers.
4. Serial to parallel converter: A serial to parallel converter is used for reconstructing parallel data from incoming serial data stream. In this technique, serial data from the

incoming serial data stream is given as data input to the demultiplexer at the regular intervals. A counter is attached to the control input of the demultiplexer. This counter directs the data signal to the output of the demultiplexer where these data signals are stored. When all data signals have been stored, the output of the demultiplexer can be retrieved and read out in parallel[5].

Actual Use of multiplexer and demultiplexer in communication

In telephony, a customer's telephone line now typically ends at the remote concentrator box, where it is multiplexed along with other telephone lines for that neighborhood or other similar area. The multiplexed signal is then carried to the central switching office on significantly fewer wires and for much further distances than a customer's line can practically go. This is likewise also true for digital subscriber lines (DSL)[6,7].

Fiber in the loop (FITL) is a common method of multiplexing, which uses optical fiber as the backbone. It not only connects POTS phone lines with the rest of the PSTN, but

also replaces DSL by connecting directly to Ethernet wired into the home. Asynchronous Transfer Mode is often the communications protocol used.

Because all the phone (and data) lines have been clumped together, none of them can be accessed except through a demultiplexer. Where such demultiplexers are uncommon, this provides for more-secure communications, though the connections are not typically encrypted.

Cable TV has long carried multiplexed television channels, and late in the 20th century began offering the same

Services, as telephone companies. IPTV also depends on multiplexing.

Conclusion

A MUX is an *input selector*. It allows you to select from 1 of N inputs and direct it to the output using $\lceil \lg N \rceil$ control bits. And A DeMUX is an *output selector*, letting you pick one of N outputs to direct an input to. Multiplexer and Demultiplexer have a wide range of advantages and applications. They are the main part of Communication due to which all of us can communicate.

REFERENCES

1. Dean, Tamara (2010). Network+ Guide to Networks. Delmar. pp. 82–85.
2. Debashis, De (2010). Basic Electronics. Dorling Kindersley. p. 557.
3. Lipták, Béla (2002). Instrument engineers' handbook: Process software and digital networks. CRC Press. p. 343.
4. Harris, David (2007). Digital Design and Computer Architecture. Penrose. p. 79.
5. Bates, Regis J; Bates, Marcus (2007), Voice and Data Communications, ISBN 9780072257328
6. Iop Science <http://iopscience.iop.org/1367-2630/14/3/033001>
7. "Twisted light' carries 2.5 terabits of data per second". BBC News. 2012-06-25. Retrieved 2012-06-25.