

Optimize the Size and Placement of Battery Storage in the Distribution System Is Based On the Size of the Solar Voltage Regulator Monitoring Through Iot

1.Aitha Sindhuja,2.Ayesha Bano

1.Pg Scholar, Department of ECE, Department of ECE, Vaageswari College of engineering, Karimnagar

²Assistant Professor, Department of ECE, Department of ECE, Vaageswari College of engineering, Karimnagar

ABSTRACT:

The demand for the renewable energy sources (RES) is increasing in the recent years. This paper presents a model and an idea to make the RES more advantageous by calculating the amount of required power that would be consumed by the electrical appliances. Therefore, the system becomes optimal as the required amount of energy is calculated and used. As the Renewable Energy Sources are more valuable nowadays, the storage of energy makes the system more reliable. Thus the combination of the renewable energy systems and battery storage is preferred for residential as well as industrial applications to utilize the optimal amount of energy.

KEY WORDS: Hybrid Renewable Energy Sources, Sizing, Optimized Energy source.

1. INTRODUCTION The traditional use of fossil fuels for energy sources leads to many environmental concerns so there is an increase in the expectations to search for the alternate solutions. The load shedding, higher electrical tariff, cross subsidies, the more frequent power outages and inconsistent power being generated also inclines the need to look for alternate approach. As the demand for electricity increases in the recent days, many industries and residents are looking for optimized way to generate energy. The Renewable Energy Sources will fulfill their needs when there is an increase in the demand for electrical consumption. The Renewable Energy is

either directly or indirectly derived from sun. The Non Renewable Energy is the energy derived from fossil fuels. There are various types of Renewable and Non Renewable Energy sources available. The Table.1, gives more information on the types of Renewable and Non Renewable Energy Sources. In case of any failures in the renewable energy system or when the source for producing renewable energy is not sufficient to generate energy, the system becomes useless and it impacts the dependent applications. In such cases, the Hybrid Renewable Energy Sources (HRES) play a vital role. For example, the when there is not enough sunlight to generate

energy and only the Solar panel PV is installed, there arises an issue of shortage in the energy generated. The HRES becomes applicable in this case, When Solar panel is used in combination along with the Wind turbines, the demanded energy generation is split between these two sources and thus the system is less dependent on one intermittent RES. This aids a high security to the energy supply. The proposed system makes use of the solar panel / wind turbine to generate power and is being stored in the battery. This model supplies energy to the appliances based on the calculated amount of power that would be used. The embedded Real Time operating system in this model sizes the amount of energy that would be consumed, optimizes the energy consumption

Working Principle of The Proposed System: The proposed model, helps to estimate the amount of energy that would be used by the electrical appliances in real time.

The system adheres to the below two vital processes,

- Sizing of electrical load requirement and
 - Optimization of the Renewable energy source to be used.
- Sizing of electrical load requirement:
- The electrical load requirement is sent to the Ti-RTOS.

- The information amount of Renewable Energy Source (Temperature, Wind speed) is available in this embedded Real time operating system.

LITERATURE REVIEW:

Electric utility companies are concerned about potential difficulties due to the large scale penetration of photovoltaics (PVs) in the power grid. One of the challenges that may stem from the high penetration level of solar PVs and supplydemand imbalances is reverse power flow which may lead to voltage rise and variation. This issue will especially affect the distribution side of the grid where household PVs are connected [1]-[3]. In addition, voltage variation due to uncontrollable nature of PVs can have a direct impact on the operation of load tap changers, voltage-controlled capacitor banks, and line voltage regulators, which may cause additional step-voltage changes. Based on the delays (30-90s) in the control of the existing devices, minute-based stepvoltage variations may be experienced. In addition, more frequent operation of these devices leads to more maintenance requirements, which consequently makes the expected life cycle of these devices short. Therefore methods to improved voltage regulation have been developed to overcome the issue of overvoltage [4]-[6]. However,

in distribution side and Low Voltage (LV) feeders the impedance is mostly resistive and the R/X ratio is considerable, as opposed to medium voltage feeder and transmission lines. Thus, the role of active power can be as important as reactive power on voltage variations and losses in a radial LV distribution feeder. This fact justifies the investigation to solve the voltage regulation problem by employing both active and reactive power and finding a tradeoff between these two parameters to optimally regulate the voltage [7]. One of the practical and effective solutions to achieve a flexible real power control and solve the overvoltage issue is the deployment of energy storage systems [8]. Among all feasible types of energy storage technologies, a battery based energy storage system can be considered as widely used and fairly developed. As a result, batteries in the form of battery energy storage systems (BESS) and its application in electric vehicles (EVs) are being actively researched in the field of distributed generation [9]-[11]. The application of battery storage system for voltage regulation and peak load shaving is investigated in previous works [12]- [13]. It is shown in [4] how the BESS could help devices such as on-load tap changer and step voltage regulator to mitigate the overvoltage through

reducing or eliminating the burden from these devices. The optimized size and best location of BESS has not been investigated in these researches. To expand the application of BESS in distribution systems, research on BESS size optimization and placement is important and beneficial for cost justification of their commercial applications in distribution systems. Different algorithms have been proposed to minimize the size of battery storage system in [7], [14]-[17]. While many of them focus on reducing cost or increasing revenue of bulk energy arbitrage [14]-[15], some aim to compensate for intermittent nature and power fluctuation of renewable energy such as solar and wind [16]-[17]. However, these studies have not concentrated on battery storage system capability to improve the voltage regulation of the supply side of the distribution system and reduced workload on tap changer and voltage regulator. In addition, the optimal placement of battery storage system in distribution systems to affect maximum nodes voltage is yet a research topic to be addressed. In this paper, a new strategy is presented to solve the overvoltage and undervoltage issues in a distribution system with solar energy penetration. Based on the location of solar energy and amount of penetration, the size

and place of battery storage system are obtained such that a BESS with minimum size is able to improve the voltage profile at maximum number of nodes in an optimal way. This approach benefits from active and reactive power control for voltage regulation and based on the topology of distribution system the optimum ratio of exchanging active and reactive power by BESS and grid-tie inverter is calculated. In this method first the power system is presented in terms of impedance matrix which is a fast and powerful tool for power system analysis. Then the minimum transferring active and reactive power through BESS and inverter is formulated as a function of solar energy

penetration, and location of solar, battery and compensated node. For this purpose, new techniques are introduced to model the slack and PV buses, during impedance matrix analysis, to increase the accuracy of the proposed approach. In contrast to the approach in [7]-[18], in the proposed approach, instead of using load flow analysis which is a recursive algorithm, the modified impedance matrix analysis is employed which leads to an analytical solution. The size and place of BESS is directly obtained from the optimization using the developed functions compared with the time consuming scanning approaches.

3.IMPLEMENTATION:

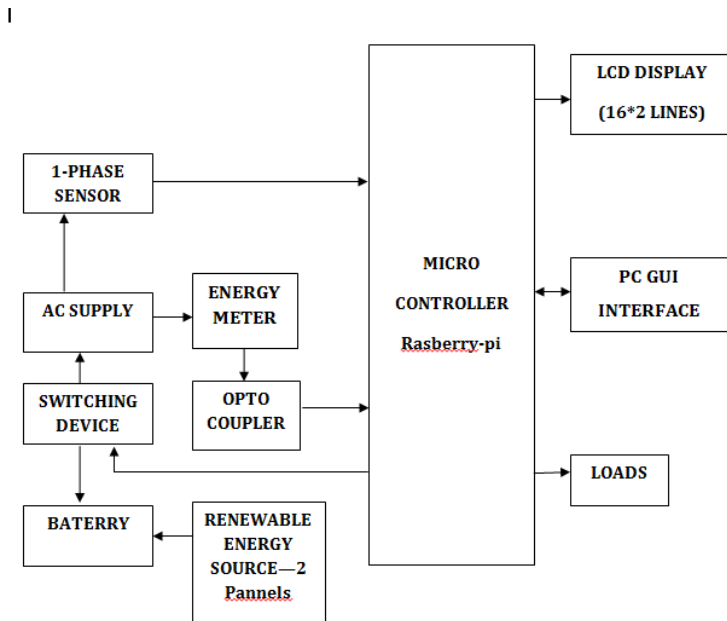

INTRODUCTION TO ARM

The ARM7 circle of relatives consists of the ARM7TDMI, ARM7TDMI-S, ARM720T, and ARM7EJ-S processors. The ARM7TDMI middle is the industry's maximum appreciably used 32-bit embedded RISC microprocessor answer. Optimized for charge and energy-touchy applications, the ARM7TDMI answer provides the low strength consumption, small length, and immoderate overall performance wanted in transportable, embedded programs.

The ARM7EJ-S processor is a synthesizable center that offers all of the benefits of the ARM7TDMI low strength consumption, small length, and the thumb coaching set even as also incorporating ARM's modern day DSP extensions and allowing acceleration of java-based packages. Compatible with the ARM9™, ARM9E™, and ARM10™ families, and Strong-Arm® structure software written for the ARM7TDMI processor is 100% binary-compatible with specific people of the ARM7 own family and forwards-like minded with the ARM9, ARM9E, and ARM10 households, in addition to products in Intel's Strong ARM and x scale architectures. This offers designers a desire of software-well suited processors with robust rate-usual performance factors.

Support for the ARM structure today includes:

- Operating structures along side Windows CE, Linux, palm and SYMBIAN OS.
- More than 40 actual-time working structures, at the side of qnx, Wind River's vxworks and mentor pics' vrtx.
- Co simulation equipment from important eda vendors
- A style of software improvement tools.

LCD:

A liquid crystal show (LCD) is a skinny, flat display device crafted from any number of color or monochrome pixels arrayed in the front of a light source or reflector. Each pixel includes a column of liquid crystal molecules suspended amongst apparent electrodes, and two polarizing filters, the axes of polarity of which might be perpendicular to each exclusive. Without the liquid crystals among them, mild passing through one is probably blocked via the opposite. The liquid crystal twists the polarization of mild getting into one filter out to permit it to pass thru the opposite.

RENEWABLE ENERGY

Renewable energy is the energy which comes from herbal assets together with sunlight, wind, rain, tides and geothermal warmth. These resources are renewable and can be evidently replenished. Therefore, for all realistic purposes, these sources can be taken into consideration to be inexhaustible, in contrast to dwindling conventional fossil fuels. The international power crunch has provided a renewed impetus to the boom and development of Clean and Renewable Energy assets. Clean Development Mechanisms (CDMs) are being adopted by corporations all across the globe. Apart from the rapidly reducing reserves of fossil fuels in the global, each different fundamental component jogging in competition to fossil fuels is the pollution related with their combustion. Contrastingly, renewable energy resources are appeared to be plenty cleaner and convey electricity with out the damaging results of pollutants not like their conventional opposite numbers. In electricity era structures based mostly on solar photovoltaic and gasoline cells (FCs) need to be conditioned for each dc and ac hundreds. The regular machine consists of strength electronics power conversion technology and may encompass strength storage primarily based on the aim

application. However, the FC systems ought to be supported thru additional energy garage unit to acquire awesome supply of power. When such structures are used to energy ac hundreds or to be related with the electricity grid, an inversion diploma is also required.

DESCRIPTION:

In this project we can keep strength consumption of different Renewable energy assets of household and also manage the appliances. Generally renewable power property are the use of correctly for circle of relatives purpose the units of load intake are transmitted. So that patron can keep records base. Hence purchaser can recognize the indoor surroundings consumption gadgets and moreover he can manipulate the residence domestic device. The EMS ensures that the important hundreds are powered whilst the AC grid fails; wherein case the VSI is controlled as a voltage supply. It also accomplishes top electricity control through imparting battery electricity to the neighborhood hundreds at the same time as they're powered by the usage of the AC grid if the loads get big. The electricity fee savings finished by means of top shaving are envisioned. The EMS functionality is validated thru experimental measurements

on a laboratory prototype. The manage architecture and right judgment embedded inside the EMS are discussed in detail.

CONCLUSION

Regarding the increased improvement of green generation such as RES, SG, and EV, which can be finding elevated economic and social recognition, planning an inexperienced electric powered power device calls for interest of those technology inside the design level. Therefore, we delivered a way for sizing an HRES running in the frame of a smart grid that coherently considers the electrical call for flexibility provided by using the usage of DSM. Contemplating a case have a have a look at for a residential microgrid in Okinawa, we studied the impact of demand flexibility on HRES sizing and estimated the capability financial advantage of such packages below remarkable situations. Generally, the most effective components sizing become suffering from call for flexibility and strongly laid low with operational conditions (eventualities), setting ahead the potential use of the added method in contemporary-day clever grid layout. The observed blessings won with the aid of using call for flexibility have been encouraging for the prolonged adoption of SG generation,

particularly even as there are barriers to the usage of BESS. In this look at, our focus turned into confined to EV as consuming factors, in which their ability use in car-to-grid utility become not considered. In destiny research, we're able to integrate vehicle-to-grid software after growing a right model for accounting to the overall performance of embedded lithiumion battery, as this may result in a greater economically and environmentally green tool.

REFERENCES

- [1] D. Feldman et al., "Photovoltaic (PV) pricing traits: Historical, latest, and near-time period projections," U.S. Dept. Energy, Washington, DC, USA, Tech. Rep. DOE/GO-102012-3839, Nov. 2012.
- [2] R. Wiser, E. Lantz, and M. Hand, "WREF 2012: The past and destiny cost of wind electricity," U.S. Dept. Energy, Washington, DC, USA, Tech. Rep. LBNL-5421E, Mar. 2012.
- [3] V. C. Güngör et al., "Smart grid technology: Communication technologies and requirements," IEEE Trans. Ind. Informat., vol. 7, no. 4, pp. 529–539, Nov. 2011.
- [4] C.-H. Lo and N. Ansari, "The revolutionary smart grid machine from each power and communications aspects," IEEE Commun. Surveys Tuts., vol. 14, no. Three, pp. 799–821, Jul. 2011.

[5] W. Kempton and J. Tomić, “Vehicle-to-grid power implementation: From stabilizing the grid to helping big-scale renewable strength,” *J. Power Sources*, vol. 144, no. 1, pp. 280–294, Jun. 2005.

[6] T. Wu, Q. Yang, Z. Bao, and W. Yan, “Coordinated strength dispatching in microgrid with wind power generation and plug-in electric cars,” *IEEE Trans. Smart Grid*, vol. 4, no. Three, pp. 1453–1463, Sep. 2013.

[7] M. Alsayed, M. Cacciato, G. Scarcella, and G. Scelba, “Multicriteria greatest sizing of photovoltaic-wind turbine grid linked structures,” *IEEE Trans. Energy Convers.*, vol. 28, no. 2,

pp. 370–379, Jun. 2013.

[8] R. Atia and N. Yamada, “Optimization of a PV-wind-diesel machine using a hybrid genetic algorithm,” in *Proc. IEEE Elect. Power Energy Conf.*, London, ON, Canada, 2012, pp. 80–eighty five.

[9] R. Chedid and S. Rahman, “Unit sizing and control of hybrid wind-sun energy systems,” *IEEE Trans. Energy Convers.*, vol. 12, no. 1, pp. 79–eighty five, Mar. 1997.

[10] M. Sharafi and T. Y. ELMekawy, “Multi-objective optimal design of hybrid renewable electricity systems the usage of PSO-simulation primarily based technique,” *Renew. Energy*, vol. Sixty eight, pp. 67–seventy nine, Aug. 2014