

A Review on Industrial Automation Using Iot

1.CHILIPREDDY SWETHA,2. Mr. R V PRASAD BHOOKYA

1.Pg Scholar, Department Of ECE, Annamacharya Institute Of Technology And Sciences,Piglipur, Batasingaram(V), Hayathnagar(M), Ranga Reddy(D),Hyderabad.

2. Asst.Professor and Head of the Department, Department Of ECE, Annamacharya Institute Of Technology And Sciences,Piglipur, Batasingaram(V), Hayathnagar(M), Ranga Reddy(D),Hyderabad

ABSTRACT: Internet of Things (IoT) incorporates concepts from pervasive computing and enables interconnections of everyday objects equipped with ubiquitous intelligence, which becomes an integral part of the Internet. IoT has gained much attention from practitioners and researchers around the world, and spawned a wide variety of smart automated systems, such as smart buildings, smart homes, smart factories, and so on.

INTRODUCTION: Industrial control system (ICS) is a general term that encompasses several types of control systems used in industrial production, including supervisory control and data acquisition (SCADA) systems, distributed control systems (DCS), and other smaller control system configurations such as programmable logic controllers (PLC) often found in the industrial sectors and critical infrastructures. ICSs are typically used in industries such as electrical, water, oil, gas and data. Based on data received from remote stations, automated or operator-driven supervisory commands can be pushed to remote station control devices, which are often referred to as field devices. Field devices control local operations such as opening and closing valves and breakers, collecting data from sensor systems, and

monitoring the local environment for alarm conditions.

LITERATURE SURVEY: Four Switches are connected to the RF Encoder. This encoded data is transmitted through a RF transmitter module. In the receiver side, the RF receiver module receives the encoded data and decodes using an RF Decoder. This decoded output data is given to transistor drivers. Relays are driven using these transistor drivers. Up to 7A load can be connected to these loads. In this project 433 MHz RF transmitter and receiver modules are used. These are ideal for remote control applications where low cost and longer range is required. The transmitter operates from a 1.5-12V supply, making it ideal for battery-powered applications. The transmitter employs a SAW-stabilized oscillator, ensuring accurate frequency control for best range performance. The

manufacturing-friendly SIP style package and low-cost make the STT-433 suitable for

high volume applications.

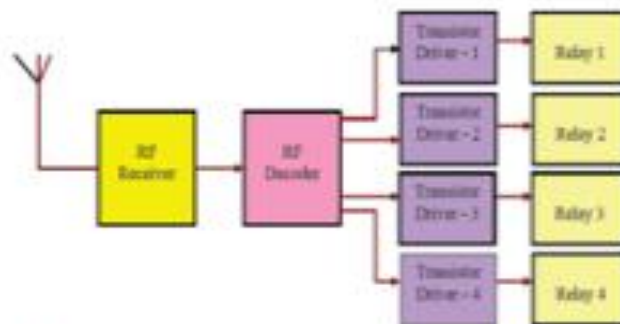
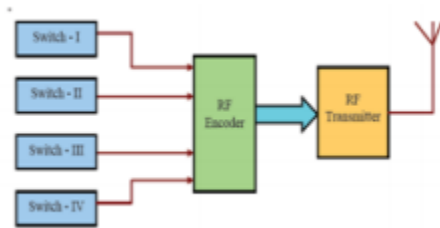

Drawback: Any one can operate these loads by using switches.

Proposed System:

We are implementing an authorized access to operate the loads/lights in a community/industry. This is to avoid unauthorized controlling of heavy machinery in an industry. This is implemented using Finger print module. Images of the authorized persons should be scanned and then the loads can be controlled using switches by them. Here we are using a technology known as Internet of things (IoT), in which we can have information wirelessly about the appliances which are

controlled by authorized person by communicating IoT module with the controlling system. The main system of the project is ARM7 LPC2148 microcontroller to which all input outputs are interfaced. The input to system is Finger print module and outputs are LCD, IoT ESP8266 and loads. The ARM7 LPC2148 takes input through switches and gives output to the loads which are interfaced through TRIAC and driver circuit. The status of the system is being displayed on LCD.

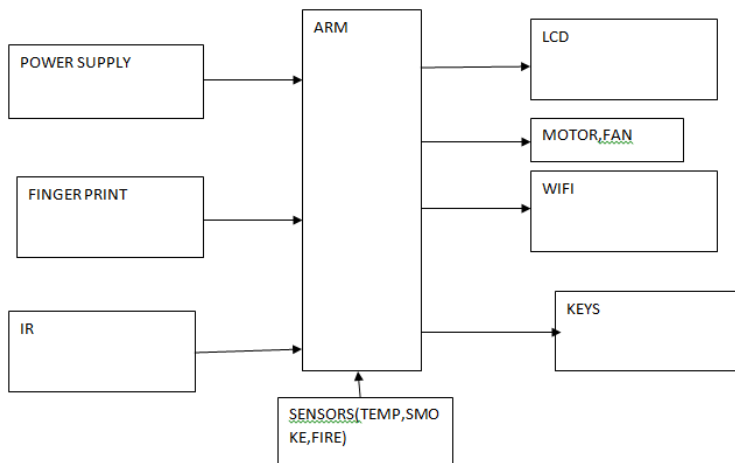

Each other using Internet? Internet of things helps the things to communicate each other using IoT module.

ESP8266EX The Internet of Things (IoT) is the network of physical objects or "things" embedded with electronics, software, sensors, and network connectivity, which enables these objects to collect and exchange data.

Wi-Fi module

ESP8266EX offers a complete and self-contained WiFi networking solution; it can be used to host the application or to offload WiFi networking functions from another application processor. When ESP8266EX hosts the application, it boots up directly from an external flash. It has integrated cache to improve the performance of the system in such applications. Alternately, serving as a WiFi adapter, wireless internet access can be added to any micro controller-based design with simple

connectivity (SPI/SDIO or I2C/UART interface). ESP8266EX is among the most integrated WiFi chip in the industry; it integrates the antenna switches, RF balun, power amplifier, low noise receive amplifier, filters, power management modules, it requires minimal external circuitry, and the entire solution, including front-end module, is designed to occupy minimal PCB area. ESP8266EX also integrates an enhanced version of Tensilica's L106 Diamond series 32-bit processor, with on-chip SRAM, besides the WiFi functionalities. ESP8266EX is often integrated with external sensors and other application specific devices through its GPIOs; sample codes for such applications are provided in the software development kit (SDK).

Features

- 802.11 b/g/n
- Integrated low power 32-bit MCU

- Integrated 10-bit ADC
- Integrated TCP/IP protocol stack
- Integrated TR switch, balun, LNA, power amplifier and matching network
- Integrated PLL, regulators, and power management units
- Supports antenna diversity
- WiFi 2.4 GHz, support WPA/WPA2
- Support STA/AP/STA+AP operation modes
- Support Smart Link Function for both Android and iOS devices
- SDIO 2.0, (H) SPI, UART, I2C, I2S, IR Remote Control, PWM, GPIO
- STBC, 1x1 MIMO, 2x1 MIMO
- A-MPDU & A-MSDU aggregation & 0.4s guard interval
- Deep sleep power < 5uA
- Wake up and transmit packets in < 2ms
- Standby power consumption of < 1.0mW (DTIM3)
- +20 dBm output power in 802.11b mode

WIRELESS IOT IMPROVES PERFORMANCE THROUGHOUT THE ENTERPRISE VALUE CHAIN

Wireless connectivity is instrumental in the Internet of Things era and the use of wireless solutions in industrial automation is increasing rapidly at all levels of automation systems. Industrial automation systems

utilize wireless communication to connect remote and local facilities and equipment to increase operational efficiency. A wireless automation system contains a mix of network technologies, equipment and systems including enterprise and automation systems, network equipment, control devices and field devices. The most common wireless technologies in industrial automation include cellular, 802.11.x Wi-Fi, proprietary unlicensed ISM radio, Bluetooth and 802.15.4 based protocols such as Wireless HART, ISA100.11a, WIAPA and ZigBee. Berg Insight estimates that shipments of wireless devices for industrial automation applications including both network and automation equipment reached 3.7 million units worldwide in 2014. Growing at a compound annual growth rate of 23.2 percent, shipments are expected to reach 12.9 million by 2020. The installed base of wireless devices in industrial applications is forecasted to grow at a compound annual growth rate of 27.2 percent from 10.3 million connections at the end of 2014 to 43.5 million devices by 2020. Wi-Fi is widely used for backbone communications as well as in monitoring and control applications within factory automation where Industrial Ethernet has got a strong foothold. Bluetooth is also

popular – often as a point-to-point wire-replacement between for example a mobile HMI solution and a field device or control unit. 802.15.4 networks are often used to connect wireless sensors and instrumentation in process automation. Cellular connectivity is typically used for backhaul communication between plants, connecting remote devices in long haul SCADA applications and for third party access to machinery and robots. Most of the major vendors of wireless IoT devices in industrial automation offer a wide range of devices with various wireless technologies in order to support many different applications. Global automation solution providers such as Emerson, GE, ABB, Honeywell, Schneider Electric, Yokogawa and Rockwell Automation are all major providers of wireless solutions to the automation industry. As wireless solutions have become increasingly popular, more and more major automation equipment and solution vendors are offering wireless technology as part of their solutions. Eaton is a major provider of Wi-Fi and cellular devices for industrial automation applications

ADVANTAGES:

- Fit and Forget system
- Low cost and reliable circuit

- Less manpower
- accurate output.

APPLICATIONS:

- House hold applications
- Offices, industries ,
Shopping malls

CONCLUSION: This project presents a high sensitive Finger print based device control. This project is designed and implemented with ARM7 in the stream of embedded systems. Experimental work has been carried out carefully. The proposed method is verified to be highly beneficial in all places.

REFERENCES:

- 1.“Brownfield innovation” is related to “brownfield development” – a commonly used term in the IT industry to describe the development and deployment of new software in the presence of existing or legacy applications. It means any new software must take into account and coexist with the systems already in place.
2. Gartner, Hyper Cycles Research. 2014. <http://www.gartner.com/technology/research/hypecycles>.
3. Oxford Economics, <https://www.oxfordeconomics.com/forecastsandmodels/industries/data-and-forecasts/global-industrydatabank/benefits-and-uses>.

4. Elfrink, Wim. “The Internet of Things: Capturing the Accelerated Opportunity”. Cisco Blog, October 15, 2014. <http://blogs.cisco.com/ioe/the-internet-of-thingscapturing-the-accelerated-opportunity>.
5. Cisco, 2014 IoT World Forum. <http://www.iotwf.com>
6. GE press release. “GE to Open Up Predix Industrial Internet Platform to All Users”. October 9, 2014. <http://www.genewsroom.com/pressreleases/ge-openpredix-industrial-internet-platform-all-users-278755>.
7. Cisco, 2014 IoT World Forum. <http://www.iotwf.com>.



Mr. R V Prasad Bhookya received the Master of Technology degree in ES from the AITS, Batasingaram, JNTUH. He received the Bachelor Of technology degree from SKEC karepalli, JNTUH. He is currently working as Assistant Professor in Annamacharya institute of technology and sciences, Hyderabad, TS. His interest subjects are Signals and systems, Communications, Digital Electronics and etc

AUTHOR’S DETAILS:



CHILIPIREDDY SWETHA ,Master of Technology (M.TECH)---ECE,Annamacharya Institute of Technology and Sciences,Piglipur, Batasingaram(V), Hayathnagar(M), Ranga Reddy(D) Hyderabad—501512.

E-mail id:ch.swethareddy10@gmail.com cell no:-9966195039