

Power Quality Improvement by Voltage Control Using Dstatcom

1.PODHILA RENUKA,

1.PG SCHOLAR ,DEPT OF EEE(EPS) ,ANNAMACHARYA INSTITUTE OF
TECHNOLOGY AND SCIENCES, HYD, TS,INDIA

2.CHANDRA SHEKHAR

2. ASSISTANT PROFESSOR, DEPT OF EEE ANNAMACHARYA INSTITUTE OF
TECHNOLOGY AND SCIENCES, HYD,TS, INDIA

ABSTRACT This paper proposes a new topology by Distribution Static Compensator using Matlab. This proposed method of power quality improvement achieves UPF which is not possible in previous methods. Maximum UPF is maintained, while regulating voltage at the load terminal, during fluctuation of load. Dstatcom solves Power quality issues by achieving PF correction, harmonic elimination, load balancing, and voltage regulation based on the load requirement. Keywords: power quality, DSTATCOM, PF correction, harmonic elimination, load balancing, voltage control, matlab.

INTRODUCTION In recent years, Electrical Power Quality had obtained more attention in power engineering. In present day's power distribution system is suffering from severe power quality problems. These power quality problems include high reactive power burden, harmonics currents, load unbalance, excessive neutral current etc. The measure of power quality depends upon the needs of the equipment that is being supplied [1]. What is good power quality for an electric motor may not be good enough for a personal computer. Usually the term power quality refers to maintaining a sinusoidal waveform of bus

voltages at rated voltage and frequency. The waveform of electric power at generation stage is purely sinusoidal and free from any distortion. Many of the power conversion and consumption equipment are also designed to function under pure sinusoidal voltage waveforms. However, there are many devices that distort the waveform. These distortions may propagate all over the electrical network. In recent years, there has been an increased use of non-linear loads which has resulted in an increased fraction of non-sinusoidal currents and voltages in Electric Network. A Distribution System Suffers from Current as well as voltage

related Power Quality Problems, which include poor power factor, distorted source current and voltage disturbances [2]. DSTATCOM are used in the distribution system for improvement of power quality issues. The voltage sags/swells have become the main cause of equipment malfunctioning, tripping in the industries due unbalance between the power supply and demand. From the last decade, there have been considerable developments and improvements in energy storage technologies [12]. This paper considers the operation of DSTATCOM in VCM and proposes a control algorithm to obtain reference load terminal voltage. This algorithm provides both advantages of VCM and CCM. UPF operation is achieved at nominal load, whereas fast voltage regulation is provided during voltage fluctuations. At the same time reactive and harmonic component of load current is supplied by the compensator at any time of Operation. The entire control is tested with three phase four wire distribution system. This proposed algorithm is validated through simulation and experimental results.

POWER INJECTION PRINCIPLE The total apparent (complex) power that is injected into a transmission line is made up of two components, namely active and

reactive. The active power P component is the part of energy that is converted into physical energy form. The reactive power Q component helps create the indispensable magnetic medium needed for most of today's electromagnetic energy conversion devices and systems. The majority of industrial and commercial appliances require both active and reactive power components for operation. Both P and Q are needed instantly and in different quantities to meet the requirement of the electrical energy converting device connected to the AC source [3]. Reactive power can be absorbed or supplied depending on the energy medium associated with the electric device. Energy absorbing or supplying components are reactors and capacitors respectively. Reactors absorb reactive power $+Q$ and draw lagging current [15]. The consumed energy is stored as a magnetic energy in the reactor turns. Meanwhile, capacitors supply reactive power $-Q$ and draw leading current, storing it as electric charge within its dielectric medium and associated charge plates. To understand P and Q flow in a transmission system, consider a simple system that is made up of sending and receiving buses with a transmission cable in between as shown in Figure 1 [13, 14].

BLOCK DIAGRAM OF PROPOSED SYSTEM Figure-2 represents the block diagram of the proposed system. DSTATCOM regulates terminal voltage satisfactorily; depending upon the properly chosen VSI parameters. AC source is

excited with three phase voltage. Controller is activated with 5V and the drive amplifier is activated with 12V DC supply. This amplifier enhances the input values to the DSTATCOM.

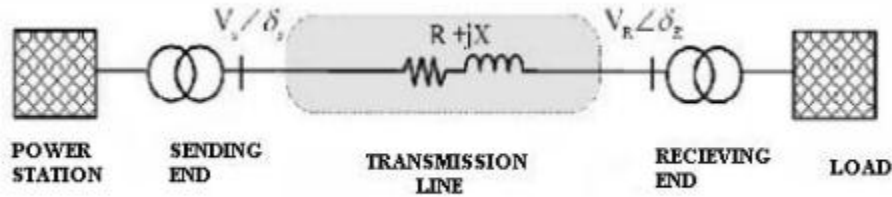

Figure-1. Transmission system.

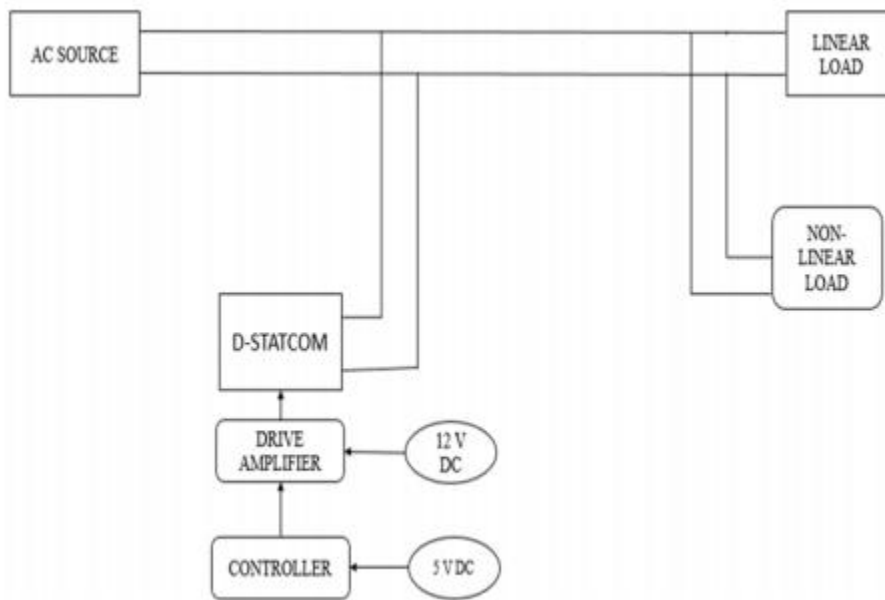

Figure-2. Block diagram.

VSI PARAMETERS DESIGN The Dc bus voltage is taken twice the peak of phase voltage of source value. Value of DC capacitors are chosen based on a period of Sag/Swell and change in DC bus voltage during transients [4]. This voltage value continues to decrease until the capacitor

voltage controller comes into action. Inductance Filter provides reasonably high switching frequency and sufficient rate of change of current so that VSI currents follow desired currents. **PROPOSED METHOD USING LINEAR LOAD** This control scheme is implemented using Matlab

2014 software. Distorted and unbalanced source currents flowing through the feeder make terminal voltages unbalanced and

distorted. Simulation parameters are mentioned below as,

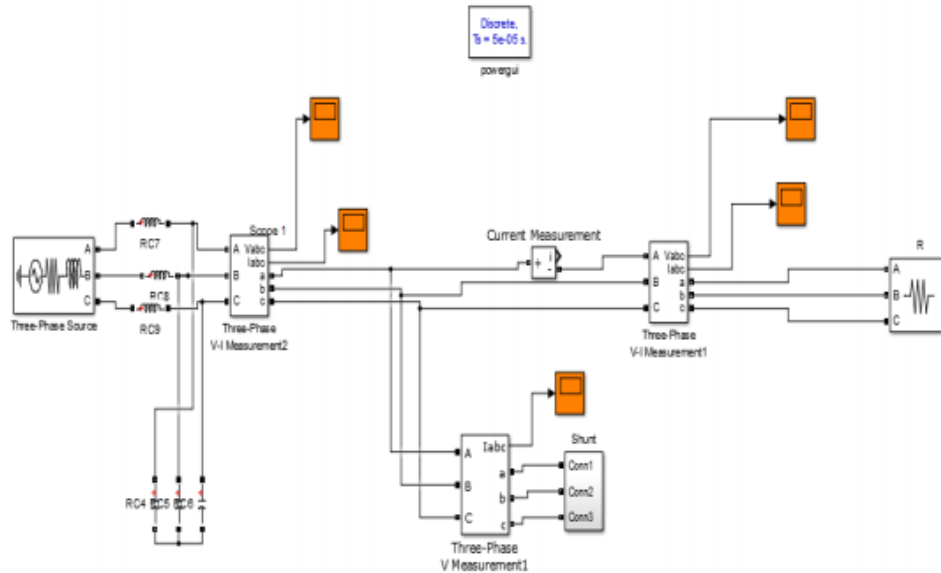

Figure-3. Simulation diagram for linear load with DSTATCOM.

The proposed method is experimentally verified on a reduced scale set up. In this method the rms value of source current is reduced from 0.61 to 0.73 A and source current is also reduced to 1.75 A from 1.84 A in this proposed method [7, 8]. Thereby losses in VSI are reduced and also capability of DSTATCOM to mitigate deep sag is increased. Hence the proposed scheme is able to provide fast voltage regulation. The experimental results are quite consistent with the simulation results. They prove the effectiveness of the proposed control system.

CONCLUSIONS In this paper, a method has been proposed for the generation of

reference load voltage for a voltagecontrolled DSTATCOM [9]. The performance of the proposed scheme is compared with the traditional voltagecontrolled DSTATCOM using linear and nonlinear load [11]. The proposed method satisfies the following conditions such that maintenance of UPF even at load changes, better voltage regulation, losses are reduced in VSI. The simulation and experimental results how that the proposed scheme provides DSTATCOM, a capability to improve several PQ problems.

REFERENCES

[1] M. Bollen. 2000. Understanding Power Quality Problems. Piscataway, NJ, USA: IEEE. 1: 1-35.

[2] H. Fujita and H. Akagi. 2007. Voltage-regulation performance of a shunt active filter intended for installation on a power distribution system. IEEE Trans. Power Electron. 22(3): 1046-1053.

[3] A. Ghosh and G. Ledwich. 2003. Load compensating DSTATCOM in weak ac systems. IEEE Trans. Power Del. 18(4): 1302-1309.

[4] A. Elnady and M. Salama. 2005. Unified approach for mitigating voltage sag and voltage flicker using the DSTATCOM. IEEE Trans. Power Del. 20(2), pt. 1: 992-1000.

[5] S. Rahmani, A. Hamadi and K. Al-Haddad. 2012. A Lyapunov-function based control for a three-phase shunt hybrid active filter. IEEE Trans. Ind. Electron. 59(3): 1418-1429.

[6] M. K. Mishra and K. Karthikeyan. 2009. A fast-acting dc-link voltage controller for three-phase DSTATCOM to compensate ac and dc loads. IEEE Trans. Power Del. 24(4): 2291-2299. [7] M. K. Mishra, A. Ghosh, A. Joshi, and H. M. Suryawanshi. 2007. A novel method of load compensation under unbalanced and distorted voltages. IEEE Trans. Power Del. 22(1): 288-295. [8] M. K.

Mishra, A. Ghosh and A. Joshi.2003. Operation of a DSTATCOM in voltage control mode. IEEE Trans. Power Del. 18(1): 258-264. A. Jain, K. Joshi, A. Behal, and N. Mohan. 2006. Voltage regulation with STATCOMs: Modeling, control and results. IEEE Trans. Power Del. 21(2): 726-735.

[9] R. Gupta, A. Ghosh and A. Joshi. 2008. Switching characterization of cascaded multilevel-invertercontrolled systems. IEEE Trans. Ind. Electron. 55(3): 1047-1058.

[10]P. Mitra and G. Venayagamoorthy. 2010. An adaptive control strategy for DSTATCOM applications in an electric ship power system. IEEE Trans. Power Electron. 25(1): 95-104.

AUTHOR'S DETAILS:



PODHILA RENUKA,

PG SCHOLAR ,DEPT OF EEE(EPS)
,ANNAMACHARYA INSTITUTE OF
TECHNOLOGY AND SCIENCES, HYD,
TS,INDIA



CHANDRA SHEKHAR

ASSISTANT PROFESSOR, DEPT OF
EEE ANNAMACHARYA INSTITUTE OF
TECHNOLOGY AND SCIENCES,
HYD,TS, INDIA